

 LOGOSOL

PAIGALDUSJUHEND

Art nr 0458-395-0427

RED:2

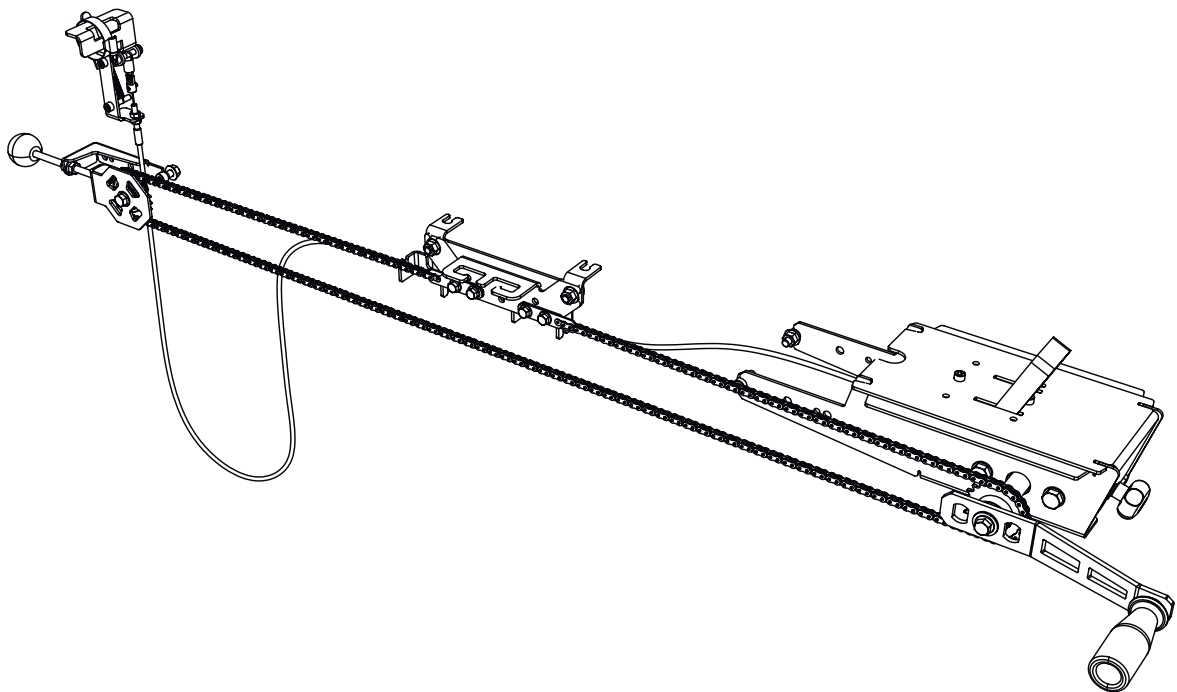









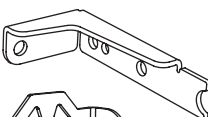
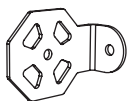

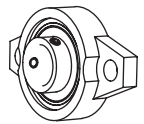
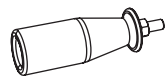

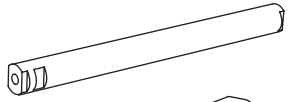

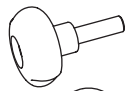
KÄSITSI KASUTATAV KAUGJUHTIMISPULT MOOTORSAELE

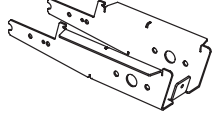
EE

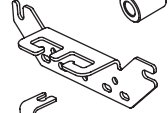
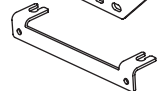
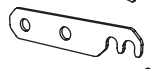

01-00696 KOOSTISOSAD

	_____	1 x	_____	03-02832
	_____	1 x	_____	03-03156
	_____	1 x	_____	04-00561
	_____	1 x	_____	03-03158
	_____	2 x	_____	04-00409
	_____	1 x	_____	DS-00169
	_____	1 x	_____	03-03239
	_____	1 x	_____	03-02819
	_____	1 x	_____	03-02813
	_____	1 x	_____	04-00407
	_____	1 x	_____	DK-00110
	_____	1 x	_____	03-02811
	_____	1 x	_____	03-03159
	_____	1 x	_____	03-02797
	_____	1 x	_____	03-02796
	_____	4 x	_____	03-03157
	_____	1 x	_____	01-00697, 4 m
	_____	1 x	_____	04-00764
	_____	1 x	_____	01-00696-skp
	_____	1 x	_____	01-00777-skp

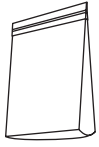

01-00696-skp

		— 3 x —	M8x20
		— 6 x —	M8
		— 4 x —	M10x25
		— 4 x —	M10
		— 1 x —	8x22x1,5
		— 4 x —	BRB 10
		— 4 x —	M8
		— 3 x —	M8x20

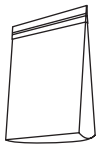

01-00777-skp

		— 4 x —	M6
		— 4 x —	M6x16
		— 1 x —	8x22x1,5
		— 1 x —	M8
		— 1 x —	M8x35

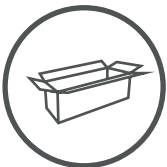

01-00695

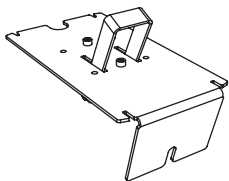

— 1 x — 01-00802

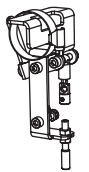

— 1 x — 01-00803



— 2 x — 03-03162



01-00701

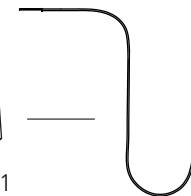

1 x – 01-00701, 4 m



01-00729



1 x – 01-00729, 4,5 m à 6 m

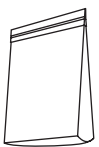

01-00720



1 x

01-00720, 1 m

Kasutatakse iga 1 m pikenduse puhul



01-00696

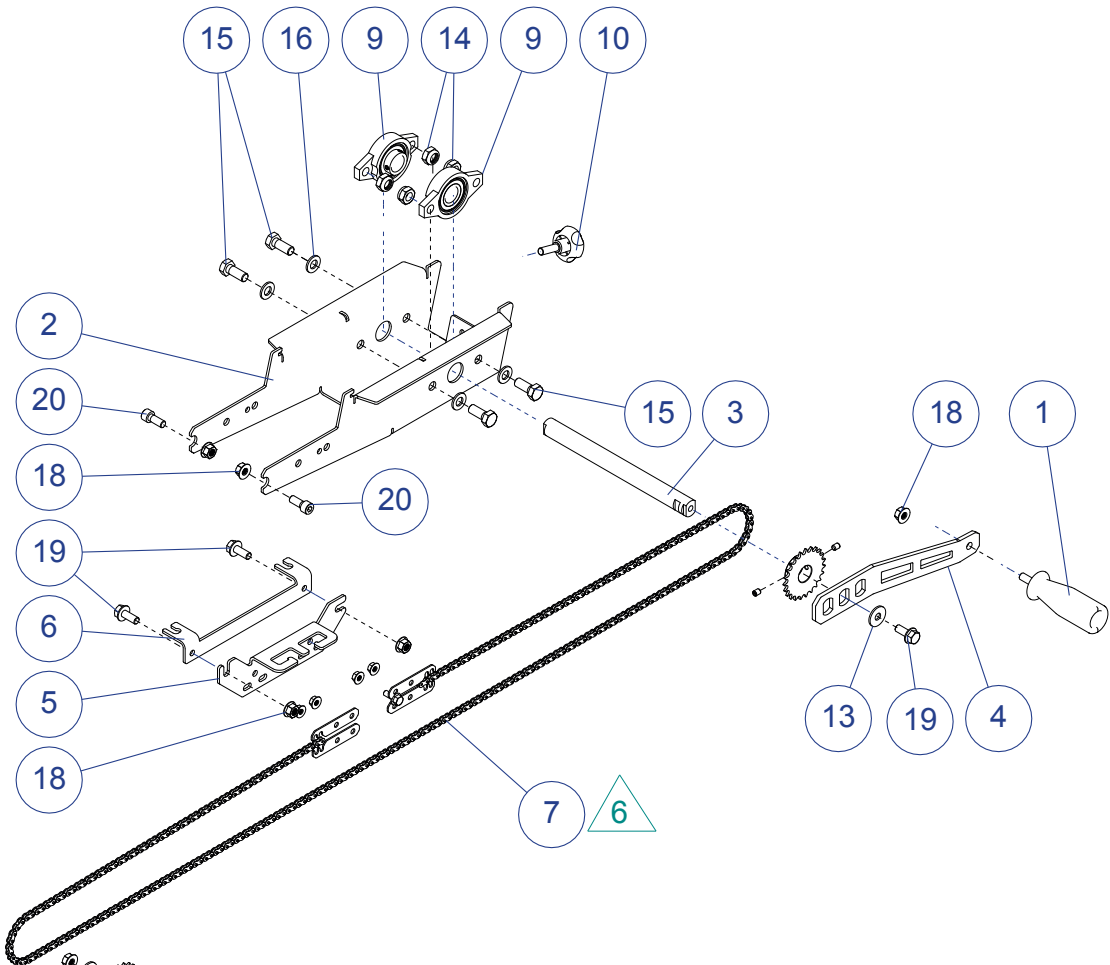

Exploded view

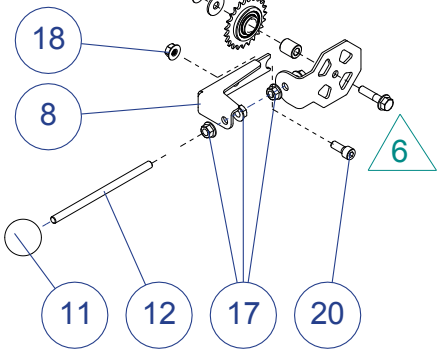

20	MC6S M8x20	3	Allen screw	
19	M6SF M8x20	3	Flange screw M6SF DIN 6921	
18	LM6MF M8 Fzb	6	Nylon lock flange nut Fzb	
17	M6MF M8	4	Flange nut M8 Fzb	
16	BRB 10	4	Washer 10,5x22 t=2 Fzb	
15	M6S M10x25	4	Hex screw M6S Fzb	
14	LM6M M10	4	Hex Nylon Lock Nut Fzb	
13	ISO 4759/3	1	Washer NB 8x22x1,5	
12	03-03239	1	Threaded rod M8x150 8.8 fzb	1
11	DK-00110	1	Endcap WN319 G32-M8	1
10	04-00407	1	Knob M8x25	1
9	04-00409	2	Flanged bearing Ø20 KFL004	1
8	03-02832	1	Turn wheel bracket	1
7	01-00777	1	Manual feed chain kit	4
6	03-02796	1	Bracket	2
5	03-02797	1	Cable & Wire mount	1
4	03-02813	1	Crank handle	1
3	03-02819	1	Crankshaft	1
2	03-02811	1	Chassis	1
1	DS-00169	1	Handle w.out end cap	2
Item no.	Art.no.	Qty.	Description	Issue



01-00777

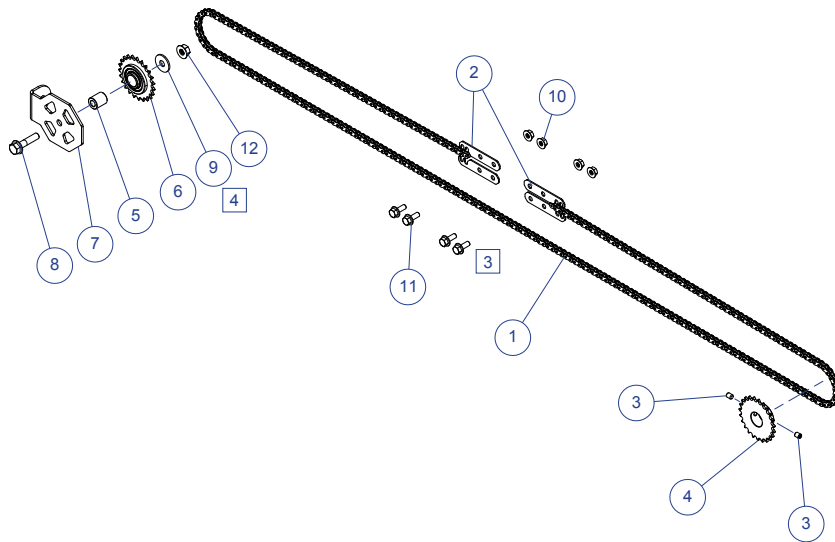

12	LM6MF M8 Fzb	1	Nylon lock flange nut Fzb	
11	M6SF M6x16	4	Flänsskruv M6SF DIN 6921	
10	LM6MF M6	4	Nylon lock flange nut Fzb	
9	ISO 4759/3	1	Washer NB 8x22x1,5	
8	M6SF M8x35	1	Flange screw M6SF DIN 6921	
7	03-03156	1	Turn wheel plate	1
6	04-00561	1	05B-1 Z=23 Tension sprocket	1
5	03-03159	1	Spacer D=15,8x8,1 L=18,5	1
4	03-03158	1	Sprocket 05B-1 z=23 d=20 L=14	1
3	P6SS M6x8	2	Pin screw	
2	03-03157	4	Chainholder	1
1	01-00697	1	Feed Chain (Manual)	1
Item no.	Art.no.	Qty.	Description	Issue

POLT/MUTTER

Kinnitusdetailide määratlus järgmistel lehtedel

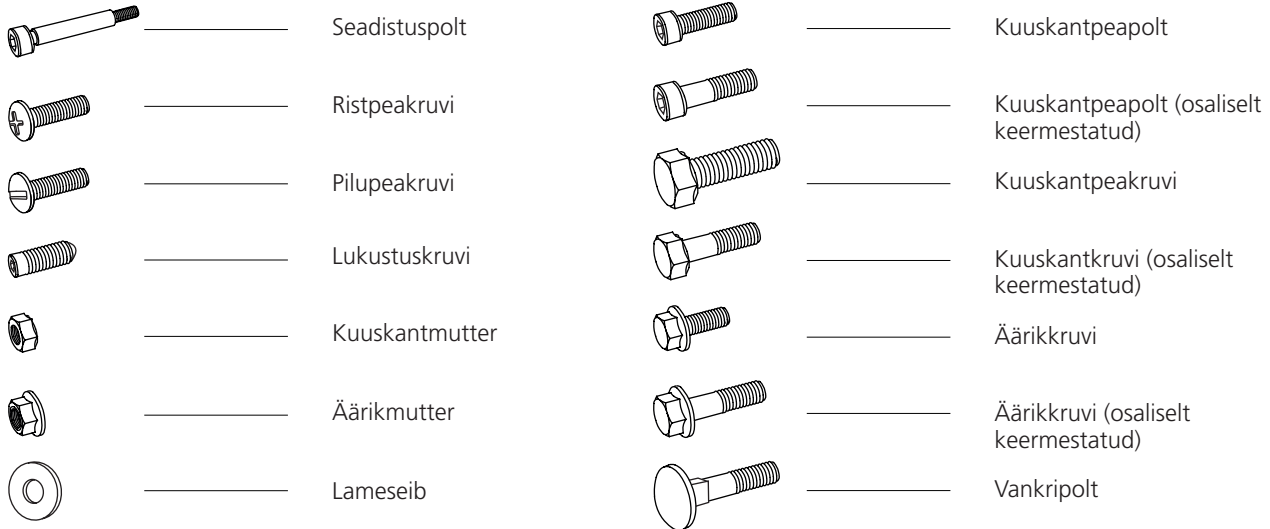

LISASÜMBOLID

Järgmisi sümboleid kasutatakse ülalloodud piltide lisana detaili kujunduse kirjeldamiseks.



Madal



Tensilock-lukk



Lukk



Süvistatud

MÕÕTMED/PIKKUS

Kinnitusdetailide mõõtmed esitatakse läbimõõduna **(M)** ISO 68-1. Sellele järgneb kruvide puhul pikkusmõõde; kruvi mõõde on kruvi see osa, mis süvistatakse paigaldatava materjali sisse.

(Läbimõõt)

M8

x

(Pikkus)







20

MONTAAŽ





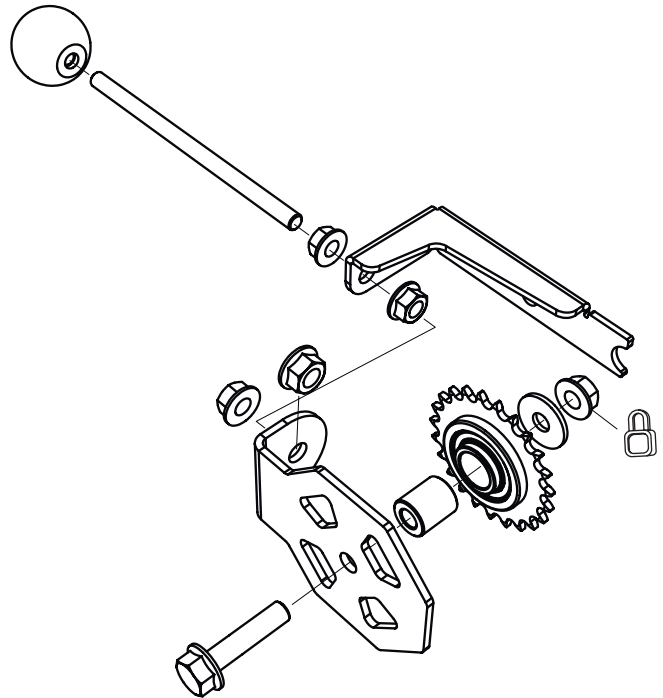

01-00696

1

-  — 1 x — 8x22x1,5
-  — 1 x — M8x35
-  — 4 x — M8
-  — 1 x — M8
-  — 1 x — 04-00561
-  — 1 x — 03-03159

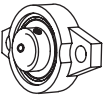



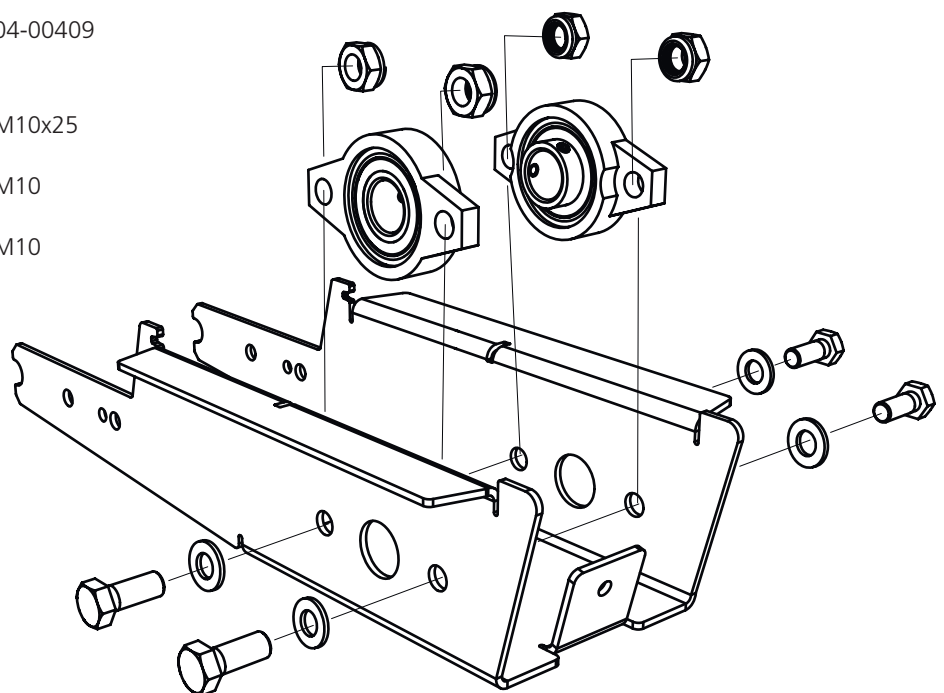

2

-  — 2 x — 04-00409
-  — 4 x — M10x25
-  — 4 x — M10
-  — 4 x — M10



3 Väнда käepideme paigaldamine

-  — 1 x — 8x22x1,5
-  — 1 x — M8x20
-  — 1 x — M8
-  — 1 x — 03-03158

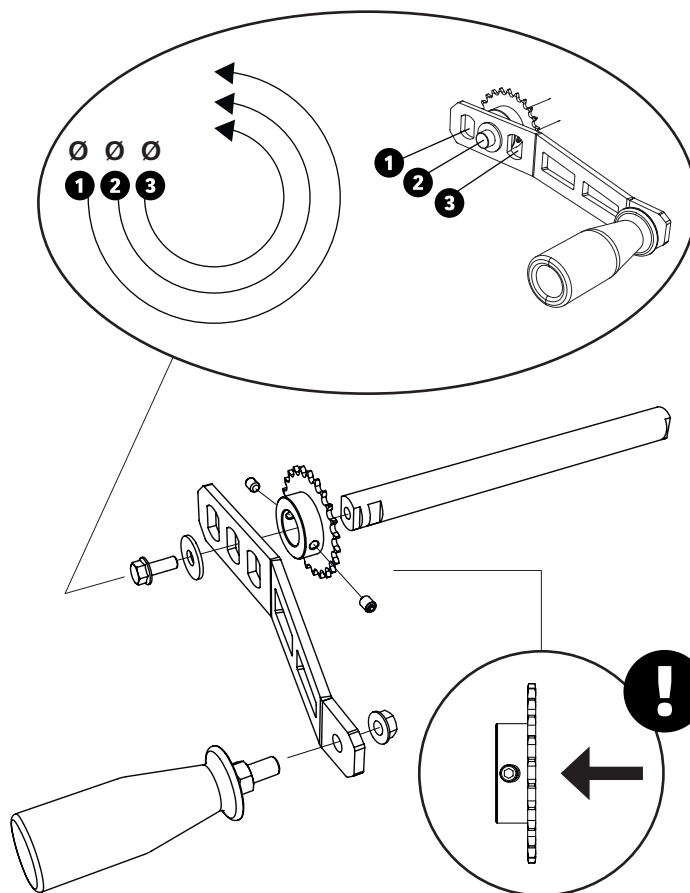

Vända käepideme saab paigaldada nii paremale kui ka vasakule küljele.

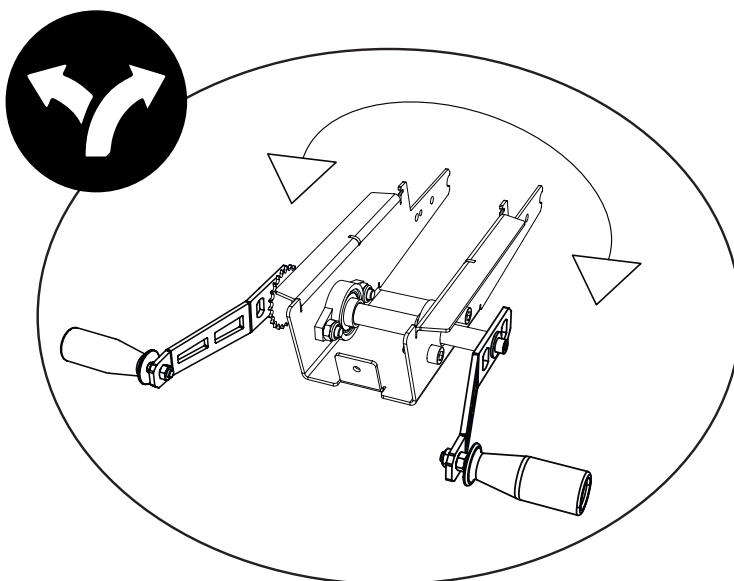

4

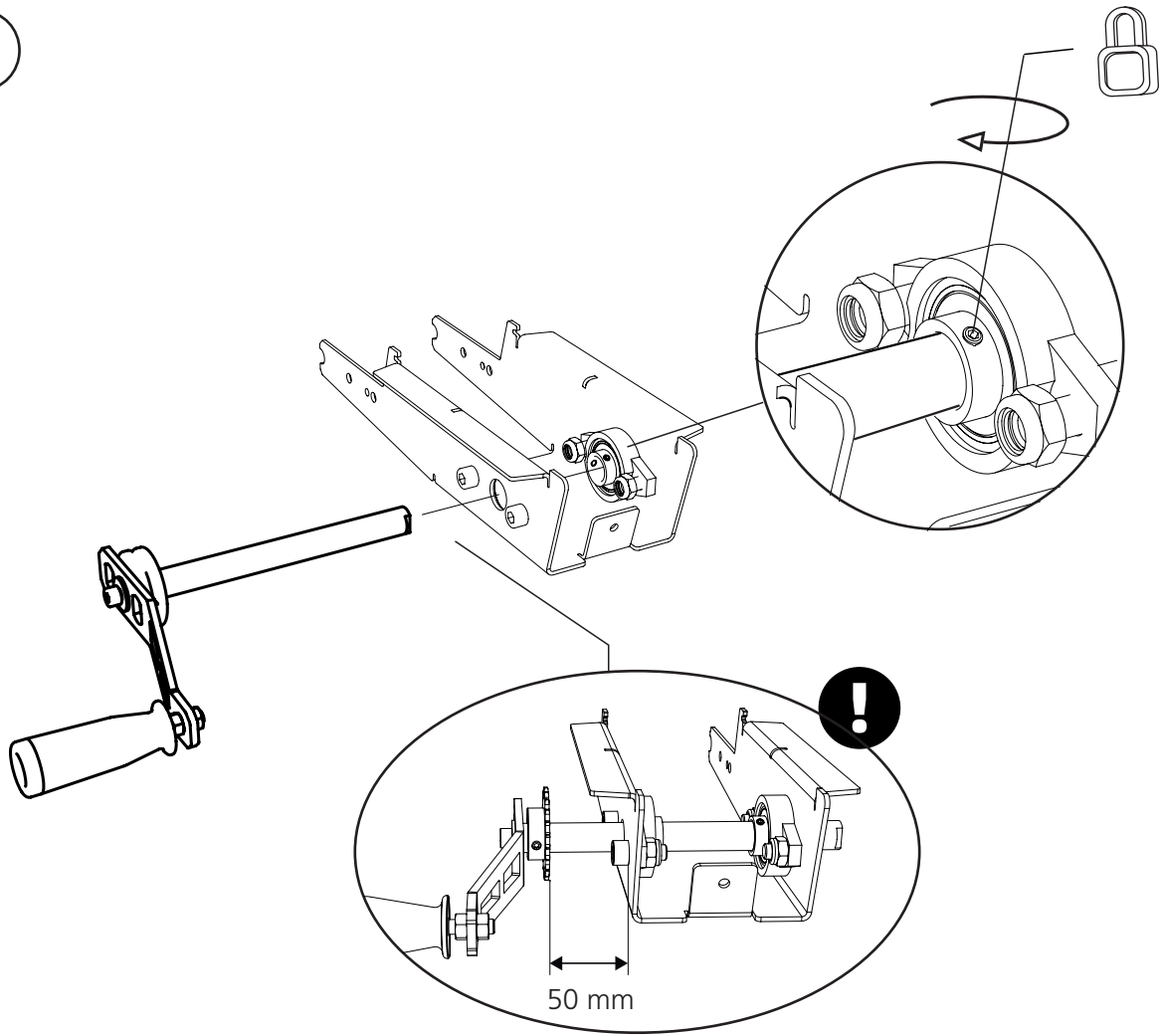

5

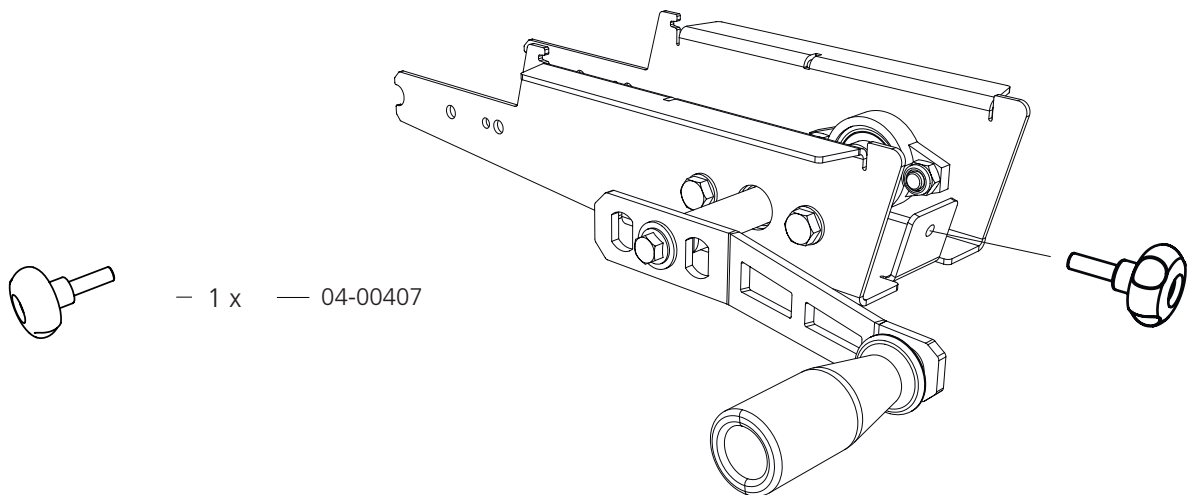

6



— 2 x ————— M8x20



— 2 x ————— M8

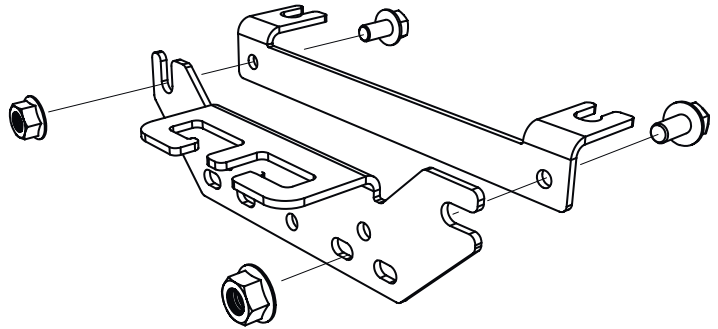

7

Montaažiks kasutatakse osaliselt kelgu olemasolevaid poltliiteid.



— 2 x ————— M8x35





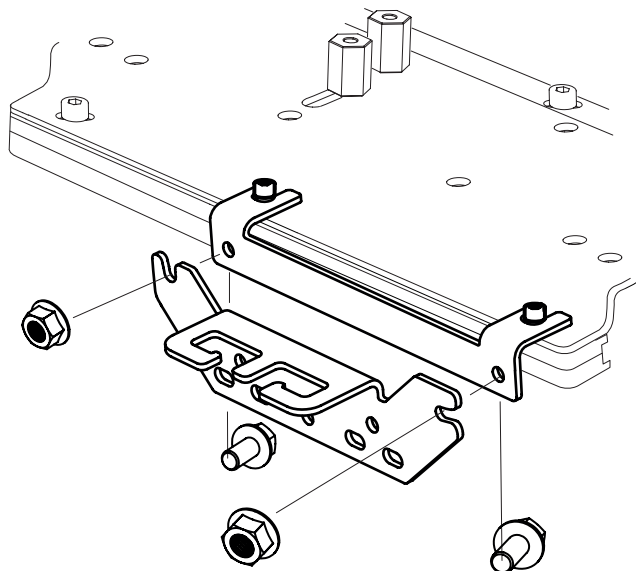
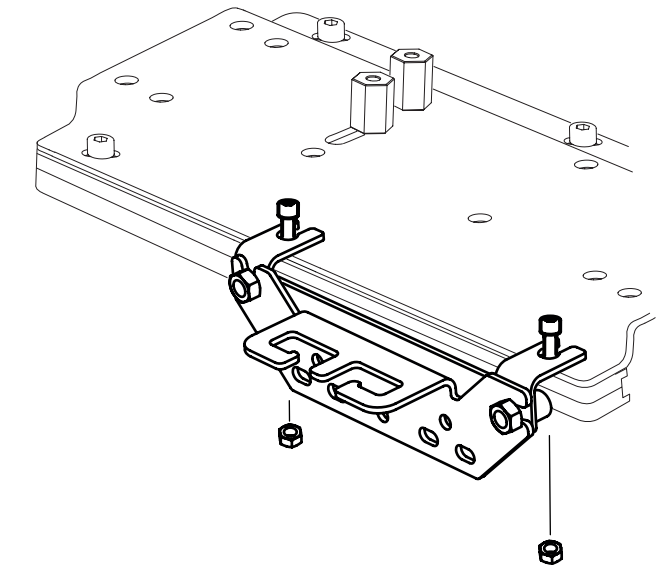

— 2 x ————— M8



Saeagregaadi hoolduse hõlbustamiseks saab trossikinnituse sae kelgult eemaldada ilma trossi pingust vähendamata.

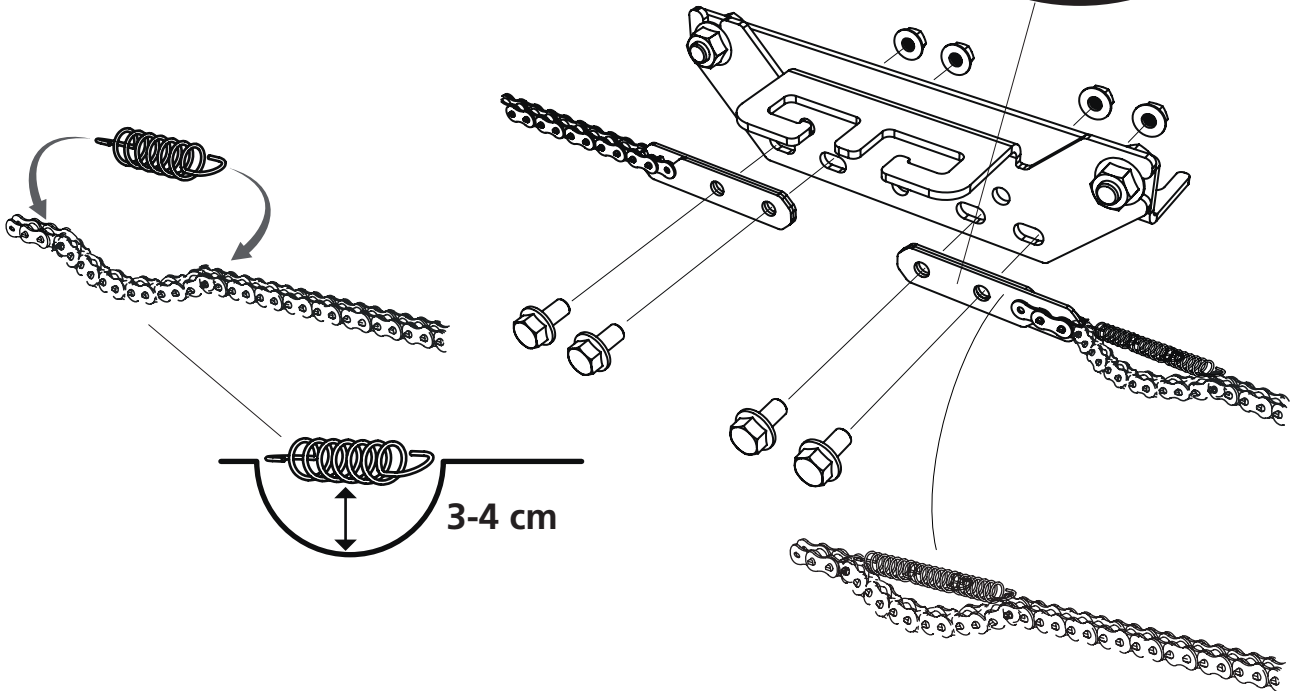
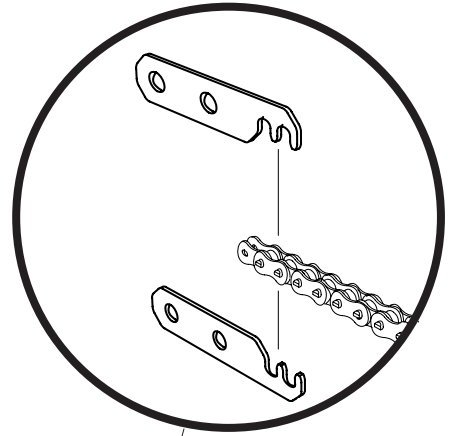

8

-  — 4 x ————— M6x16
-  — 4 x ————— M6
-  1 x ————— 01-00697, 4 m
-  1 x ————— 01-00720, 1 m
Kasutatakse iga 1 m pikenduse puhul
-  1 x ————— 04-00764



9

Montaažiks kasutatakse osaliselt tala olemasolevaid poltliiteid.

-  — 1 x ————— M8x20
-  — 1 x ————— M8

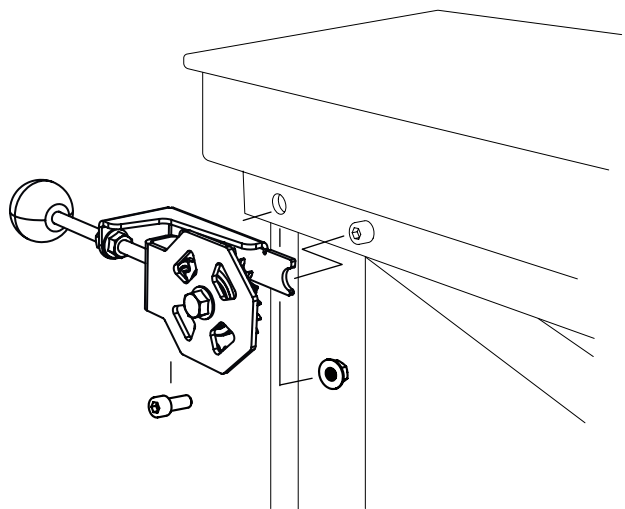

10

Montaažiks kasutatakse osaliselt tala olemasolevaid poldliiteid.

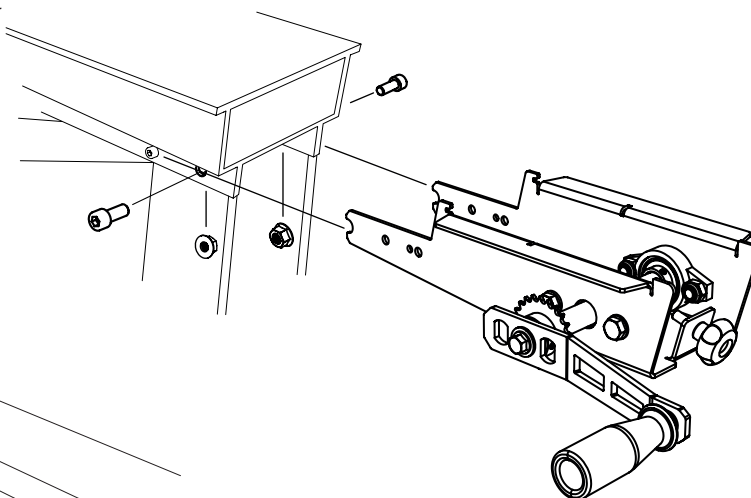
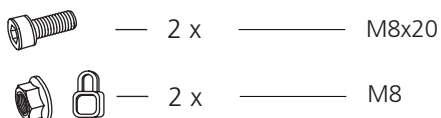

11

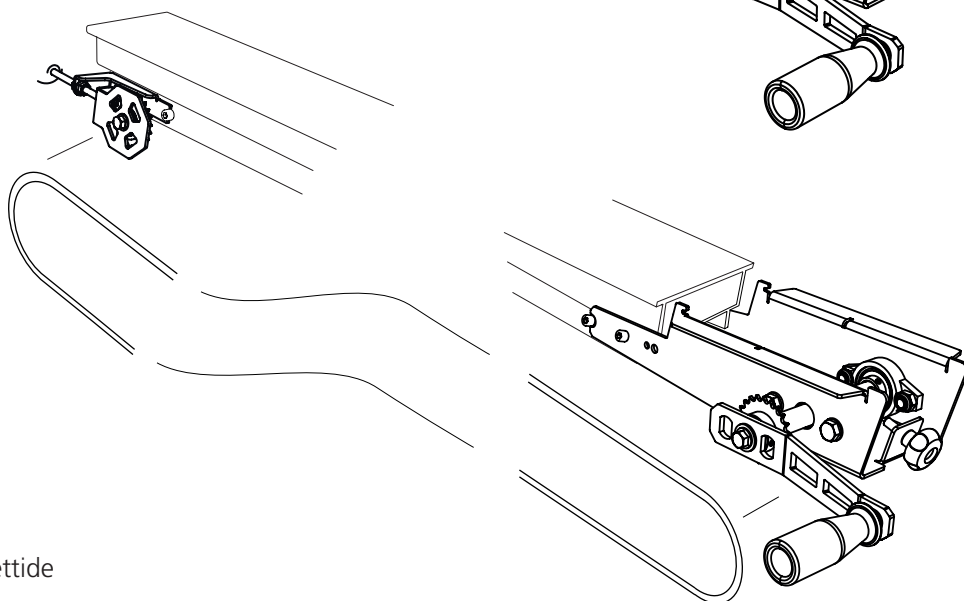
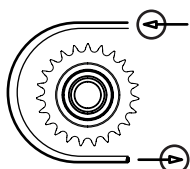

12

Pingutage veoketti nii, et kettide vahel oleks vahe 6-7 cm.

Pinguse reguleerimiseks tuleb vabastada kinnitusmehhanismi äärikmutter.

Pärast reguleerimise lõpetamist pingutage äärikmutter kindlasti uuesti.

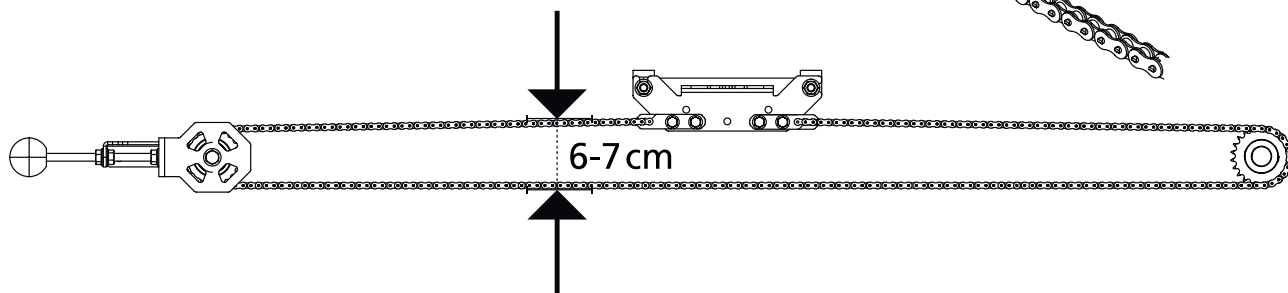
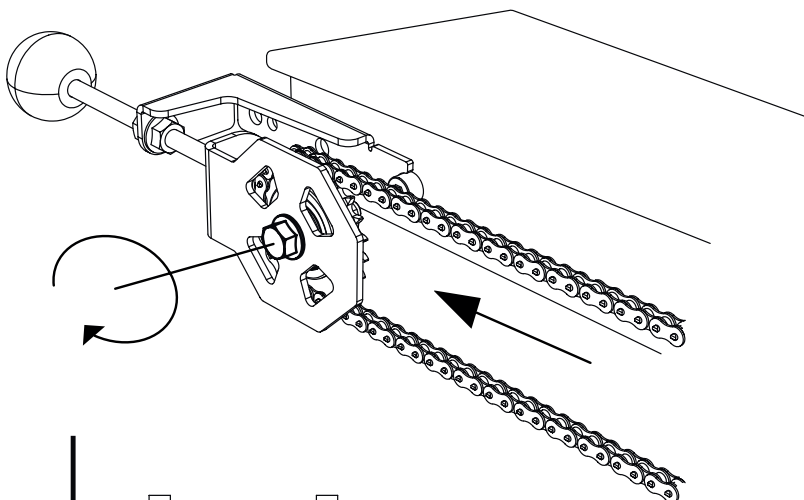

13

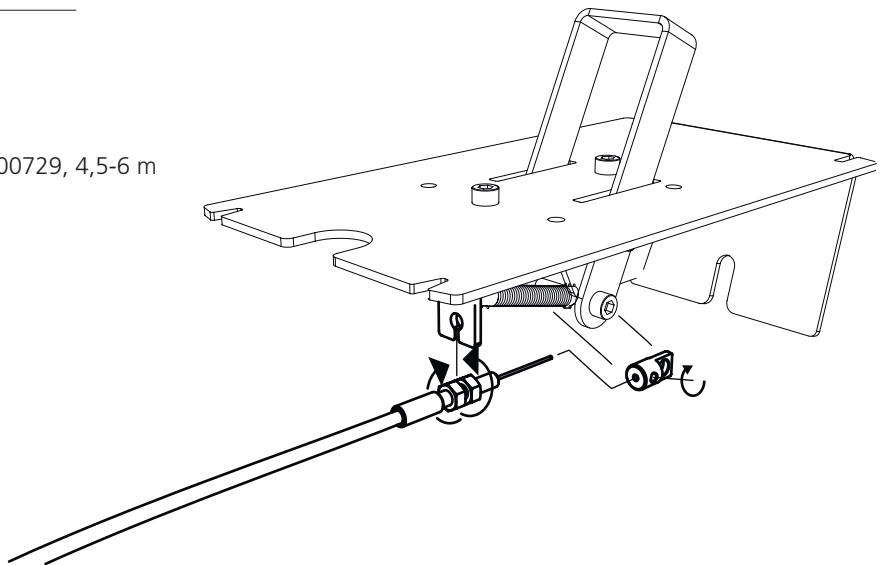
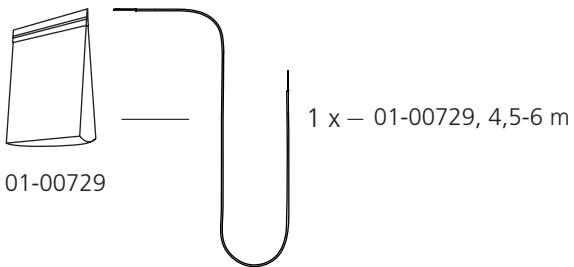
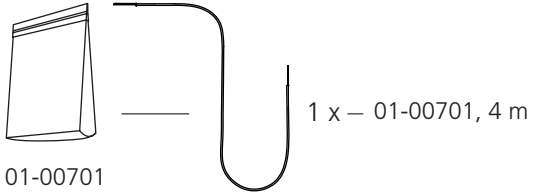

14

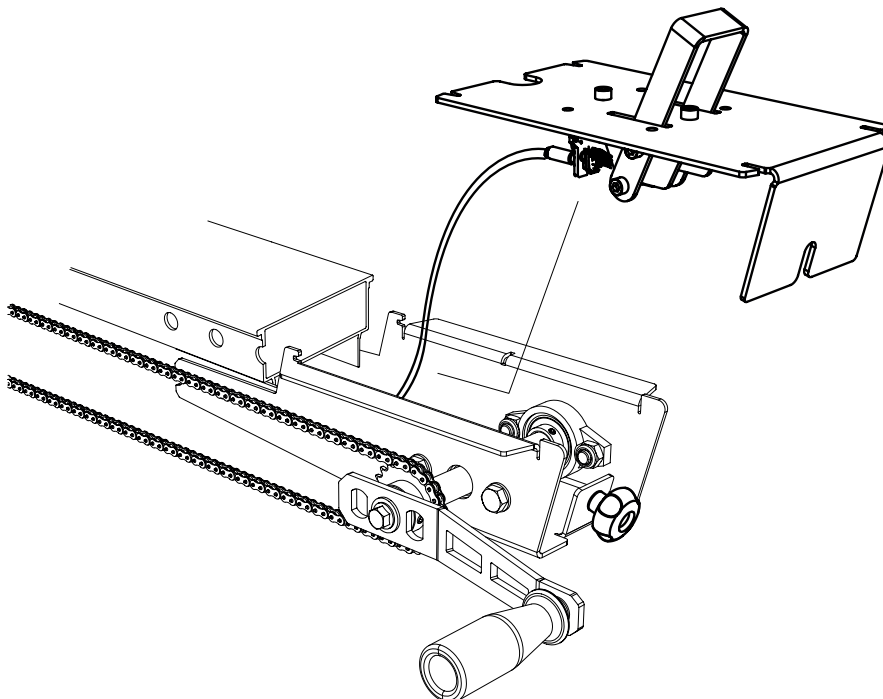

15

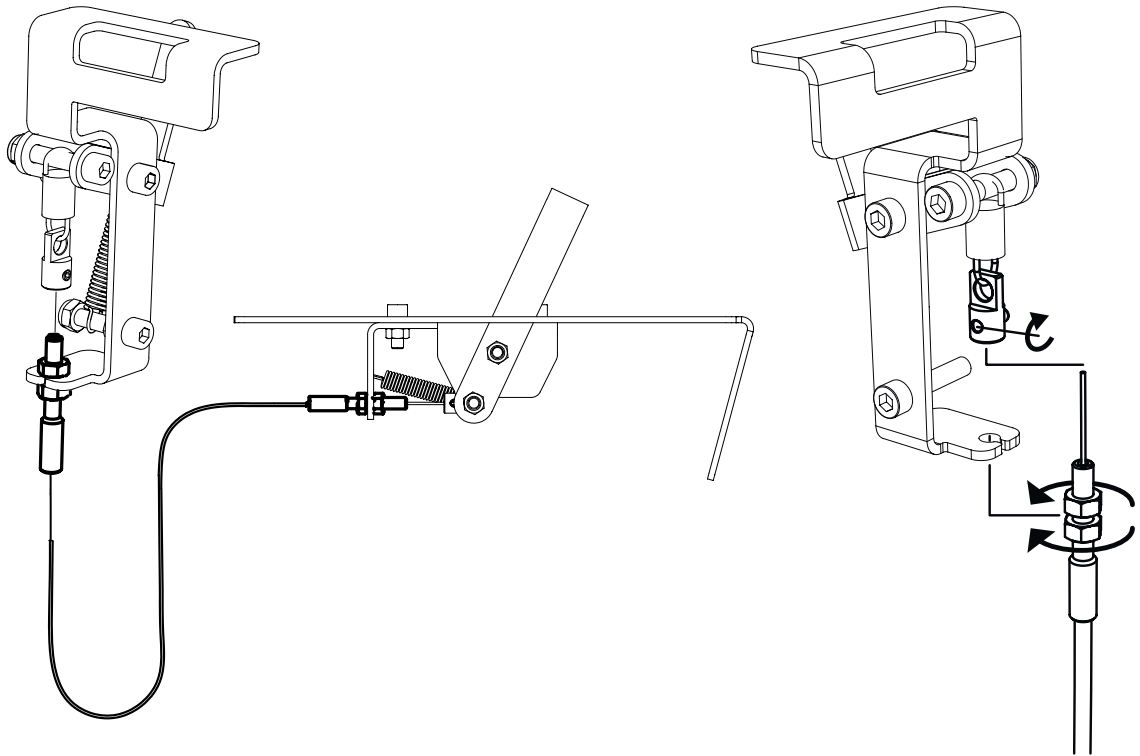

16

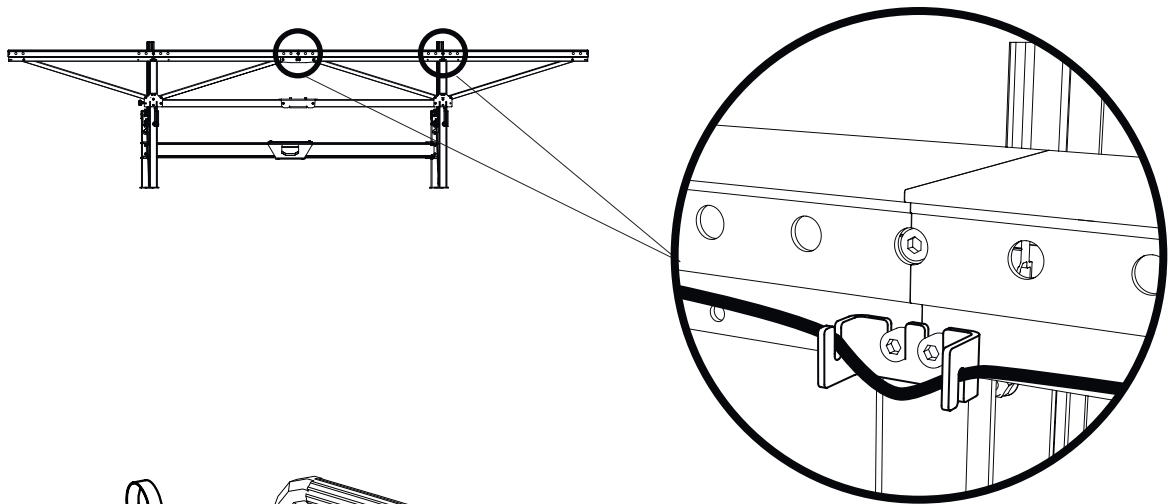

17

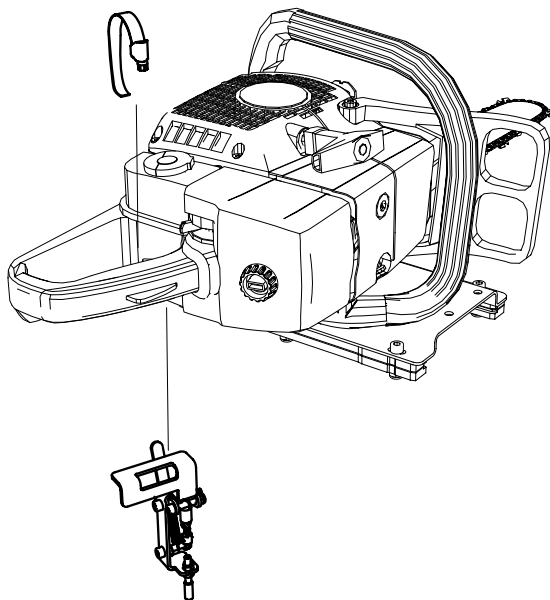

18

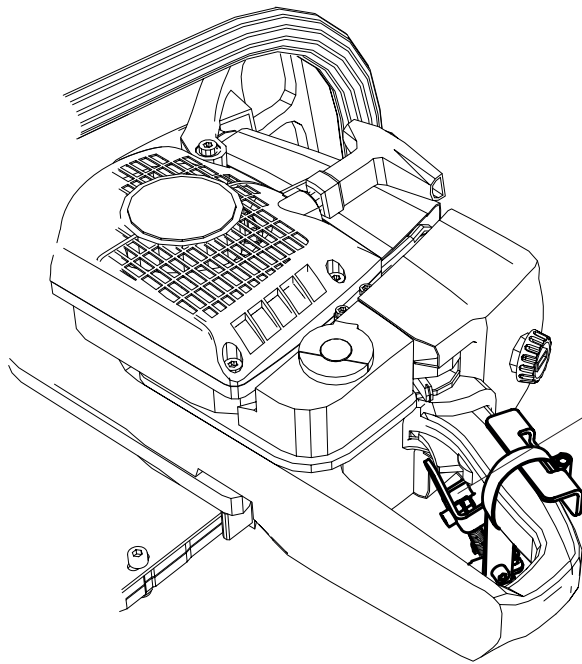

Vähemalt
3 mm

NB! Veenduge, et kaugjuhitava rõhuregulaatori ja mootorsae gaasiregulaatori vahel oleks tühikäigul vähemalt pilu 3 mm.

19

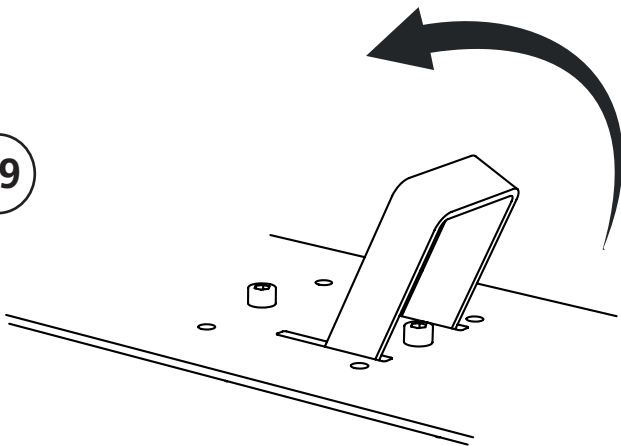

20

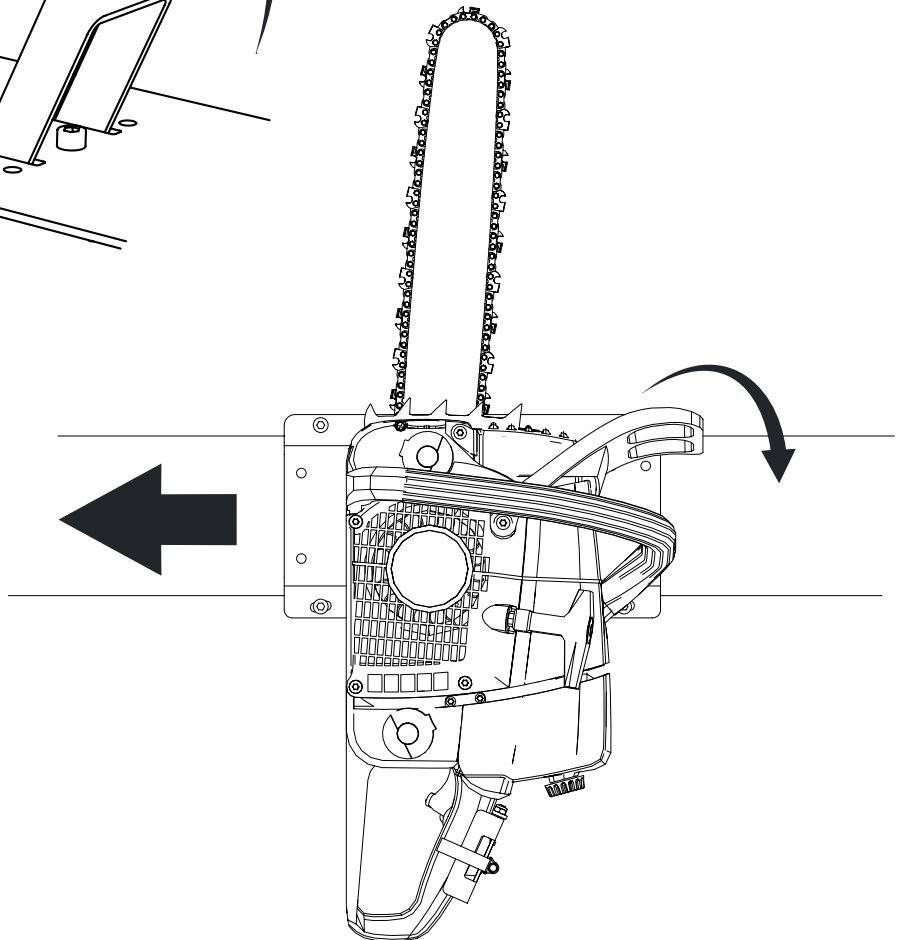



Vastavusdeklaratsioon

direktiivi 2006/42/EÜ lisa 2A kohaselt

Logosol AB
Fiskaregatan 2
871 33 Härnösand

kinnitab käesolevaga, et **Logosoli käsitsi kasutatav
kaugjuhtimispult mootorsaejooks**

on valmistatud kooskõlas järgnevaga:
Masinadirektiiv 2006/42/EÜ

ja on valmistatud kooskõlas alljärgnevate ühtlustatud
standarditega:
EN ISO 12100:2010

Tehnilise dokumentatsiooni eest vastutab tegevjuht
Fredrik Forssberg.

Härnösand 26.06.2025

Robert Berglund, tegevjuht

LOGOSOL

Arkiwägen 6, 871 53 Härnösand, Sweden
+46(0)611-182 85 | info@logosol.com | www.logosol.com