

 LOGOSOL

INSTRUKCJA MONTAŻU

Nr kat. 0458-395-0416

REV: 2

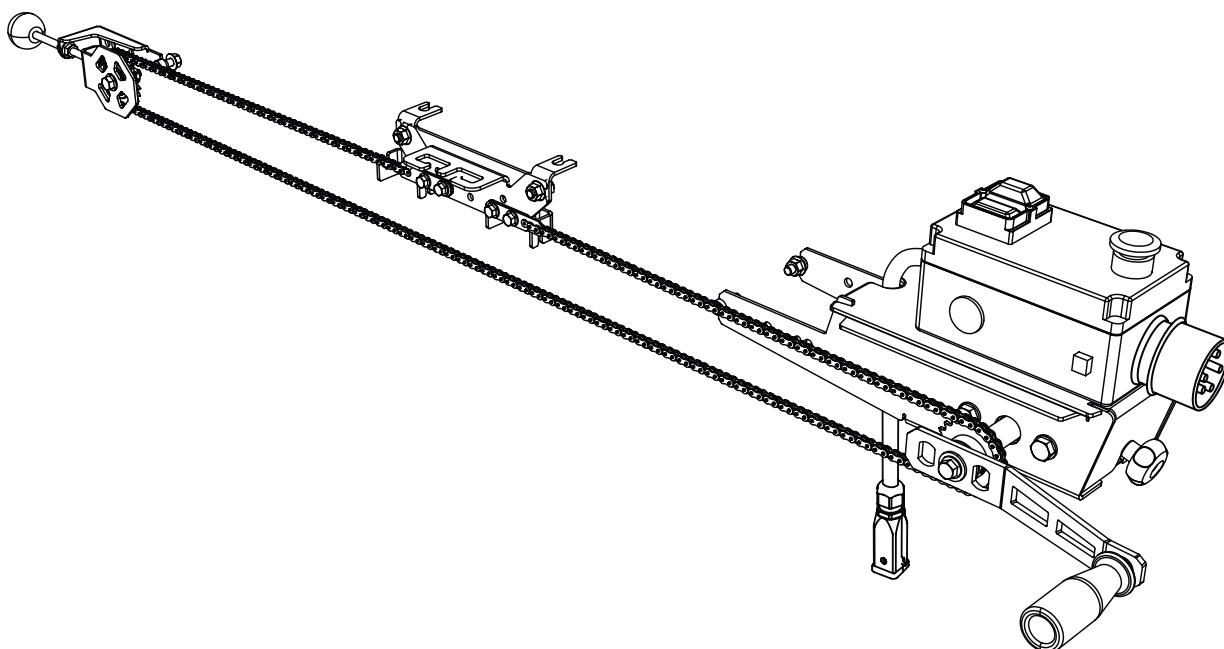









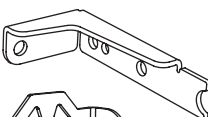
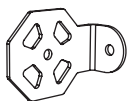

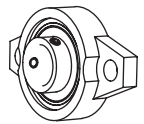
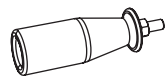

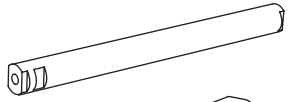

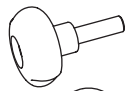
ZDALNY NAPĘD RĘCZNY DO PIŁY ELEKTRYCZNEJ

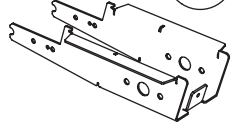
PL

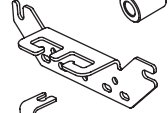
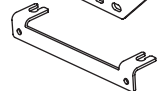
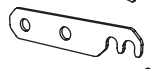

01-00696 CZĘŚCI SKŁADOWE

	_____	1 x	_____	03-02832
	_____	1 x	_____	03-03156
	_____	1 x	_____	04-00561
	_____	1 x	_____	03-03158
	_____	2 x	_____	04-00409
	_____	1 x	_____	DS-00169
	_____	1 x	_____	03-03239
	_____	1 x	_____	03-02819
	_____	1 x	_____	03-02813
	_____	1 x	_____	04-00407
	_____	1 x	_____	DK-00110
	_____	1 x	_____	03-02811
	_____	1 x	_____	03-03159
	_____	1 x	_____	03-02797
	_____	1 x	_____	03-02796
	_____	4 x	_____	03-03157
	_____	1 x	_____	01-00697, 4 m
	_____	1 x	_____	04-00764
	_____	1 x	_____	01-00696-skp
	_____	1 x	_____	01-00777-skp

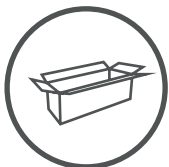
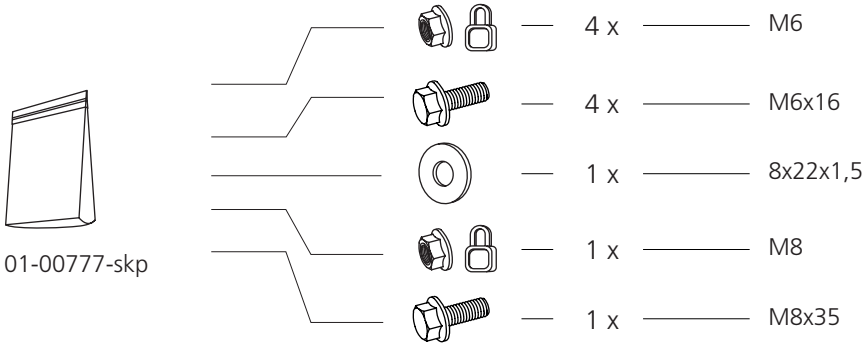
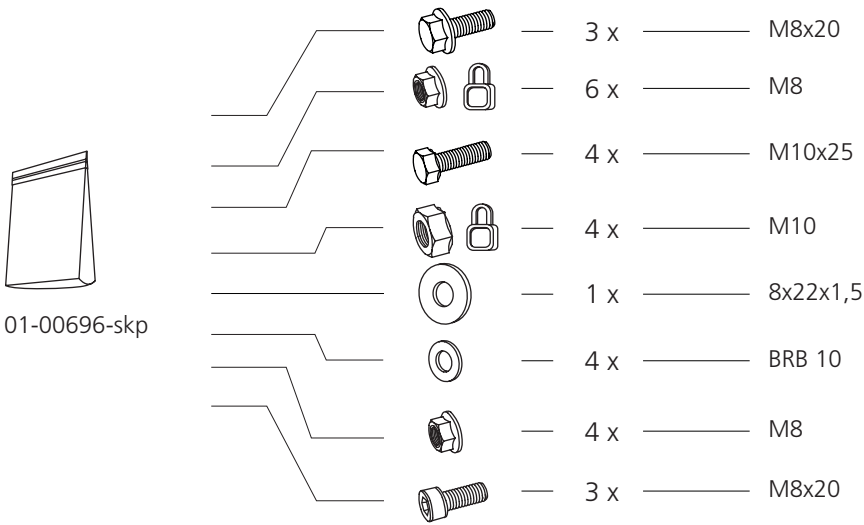

01-00804

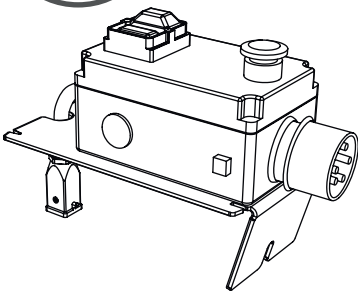

— 1 x — 01-00804

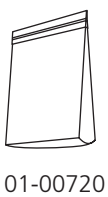

— 1 x — 01-00720, 1 m
Stosowane na każdy 1 m przedłużenia



01-00696

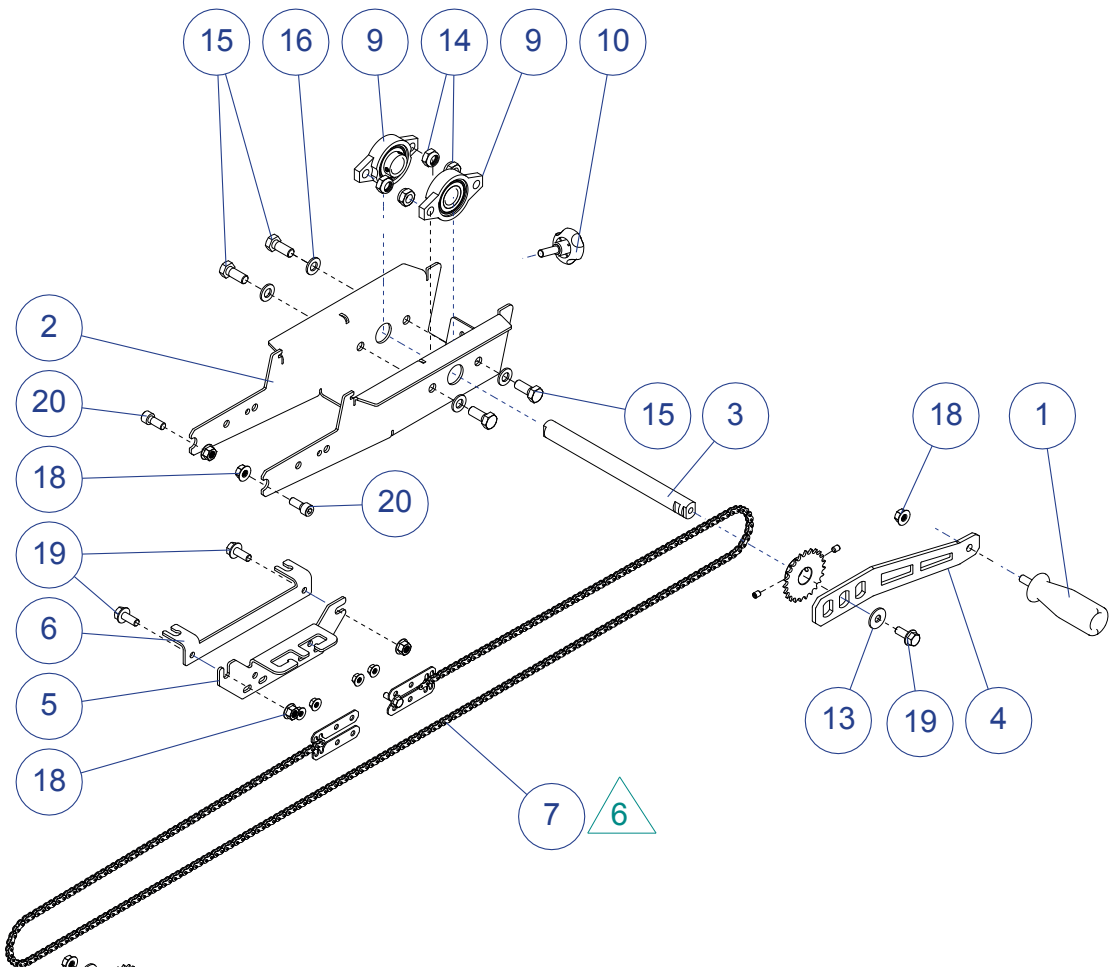

Exploded view

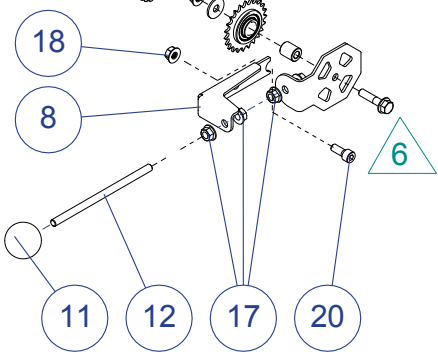

20	MC6S M8x20	3	Allen screw	
19	M6SF M8x20	3	Flange screw M6SF DIN 6921	
18	LM6MF M8 Fzb	6	Nylon lock flange nut Fzb	
17	M6MF M8	4	Flange nut M8 Fzb	
16	BRB 10	4	Washer 10,5x22 t=2 Fzb	
15	M6S M10x25	4	Hex screw M6S Fzb	
14	LM6M M10	4	Hex Nylon Lock Nut Fzb	
13	ISO 4759/3	1	Washer NB 8x22x1,5	
12	03-03239	1	Threaded rod M8x150 8.8 fzb	1
11	DK-00110	1	Endcap WN319 G32-M8	1
10	04-00407	1	Knob M8x25	1
9	04-00409	2	Flanged bearing Ø20 KFL004	1
8	03-02832	1	Turn wheel bracket	1
7	01-00777	1	Manual feed chain kit	4
6	03-02796	1	Bracket	2
5	03-02797	1	Cable & Wire mount	1
4	03-02813	1	Crank handle	1
3	03-02819	1	Crankshaft	1
2	03-02811	1	Chassis	1
1	DS-00169	1	Handle w.out end cap	2
Item no.	Art.no.	Qty.	Description	Issue



01-00777

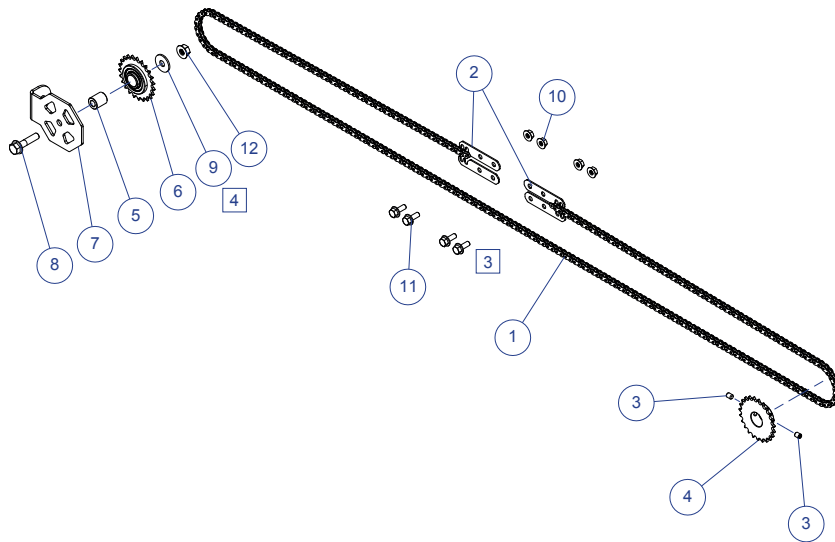

12	LM6MF M8 Fzb	1	Nylon lock flange nut Fzb	
11	M6SF M6x16	4	Flänsskruv M6SF DIN 6921	
10	LM6MF M6	4	Nylon lock flange nut Fzb	
9	ISO 4759/3	1	Washer NB 8x22x1,5	
8	M6SF M8x35	1	Flange screw M6SF DIN 6921	
7	03-03156	1	Turn wheel plate	1
6	04-00561	1	05B-1 Z=23 Tension sprocket	1
5	03-03159	1	Spacer D=15,8x8,1 L=18,5	1
4	03-03158	1	Sprocket 05B-1 z=23 d=20 L=14	1
3	P6SS M6x8	2	Pin screw	
2	03-03157	4	Chainholder	1
1	01-00697	1	Feed Chain (Manual)	1
Item no.	Art.no.	Qty.	Description	Issue

ŚRUBA/NAKRĘTKA

Definicja elementów złącznych na kolejnych stronach.



SYMBOLE DODATKOWE

Do opisu konstrukcji szczegółów, oprócz powyższych ilustracji, stosuje się następujące symbole.



Niska



Kołnierz ząbkowany



Blokada



Wpuszczana

WYMIARY/DŁUGOŚĆ

Wymiary elementów łączących są drukowane jako wymiar średnicy (**M**) ISO 68-1. Następnie w przypadku śrub mamy do czynienia z pomiarem długości, wymiar śruby to ta część śruby, która znika w materiale, w którym jest montowana.

(Średnica)

M8

(Długość)

x







20

MONTAŻ





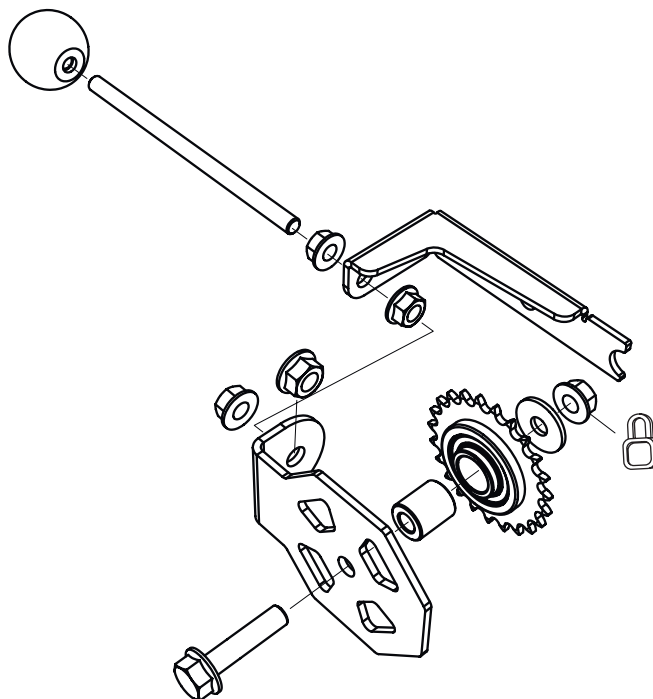

01-00696

1

-  — 1 x — 8x22x1,5
-  — 1 x — M8x35
-  — 4 x — M8
-  — 1 x — M8
-  — 1 x — 04-00561
-  — 1 x — 03-03159





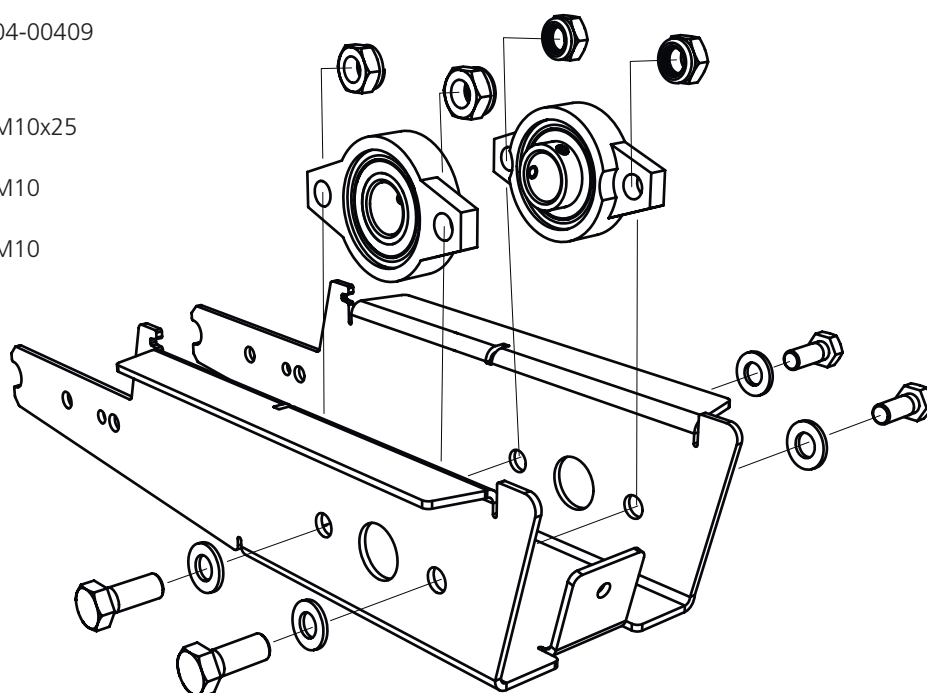

2

-  — 2 x — 04-00409
-  — 4 x — M10x25
-  — 4 x — M10
-  — 4 x — M10



3

Montaż uchwyty korbey

-  — 1 x — 8x22x1,5
-  — 1 x — M8x20
-  — 1 x — M8
-  — 1 x — 03-03158

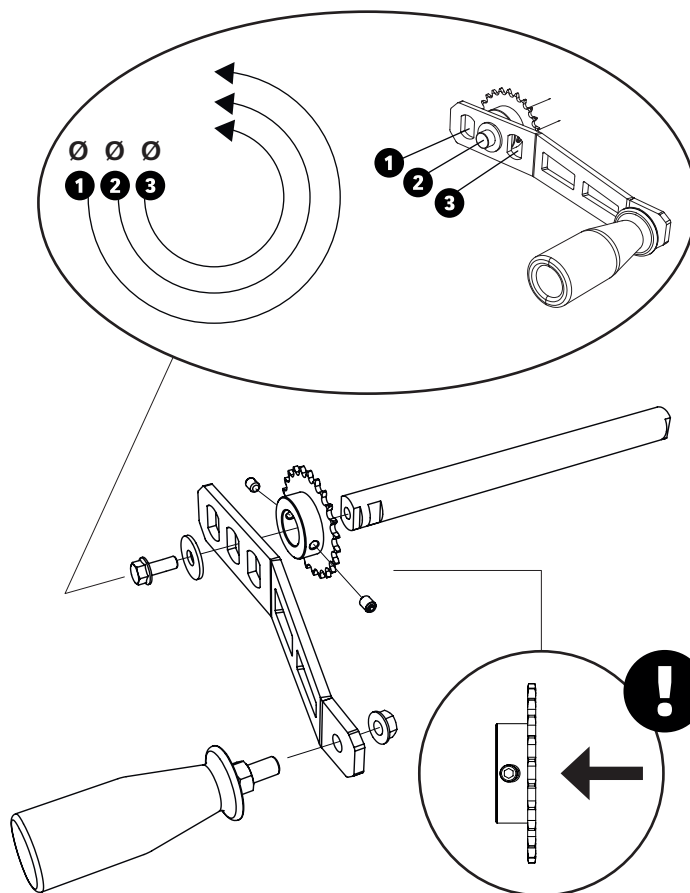

Uchwyt korbey można zamontować zarówno po prawej, jak i po lewej stronie.

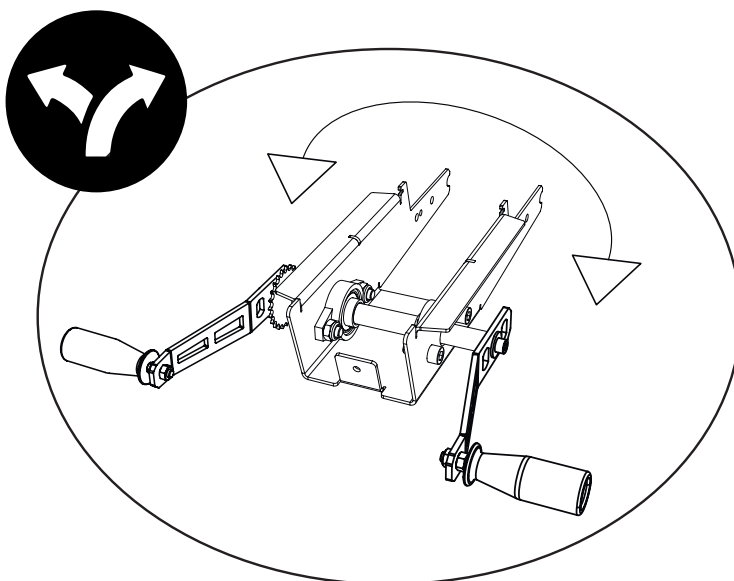

4

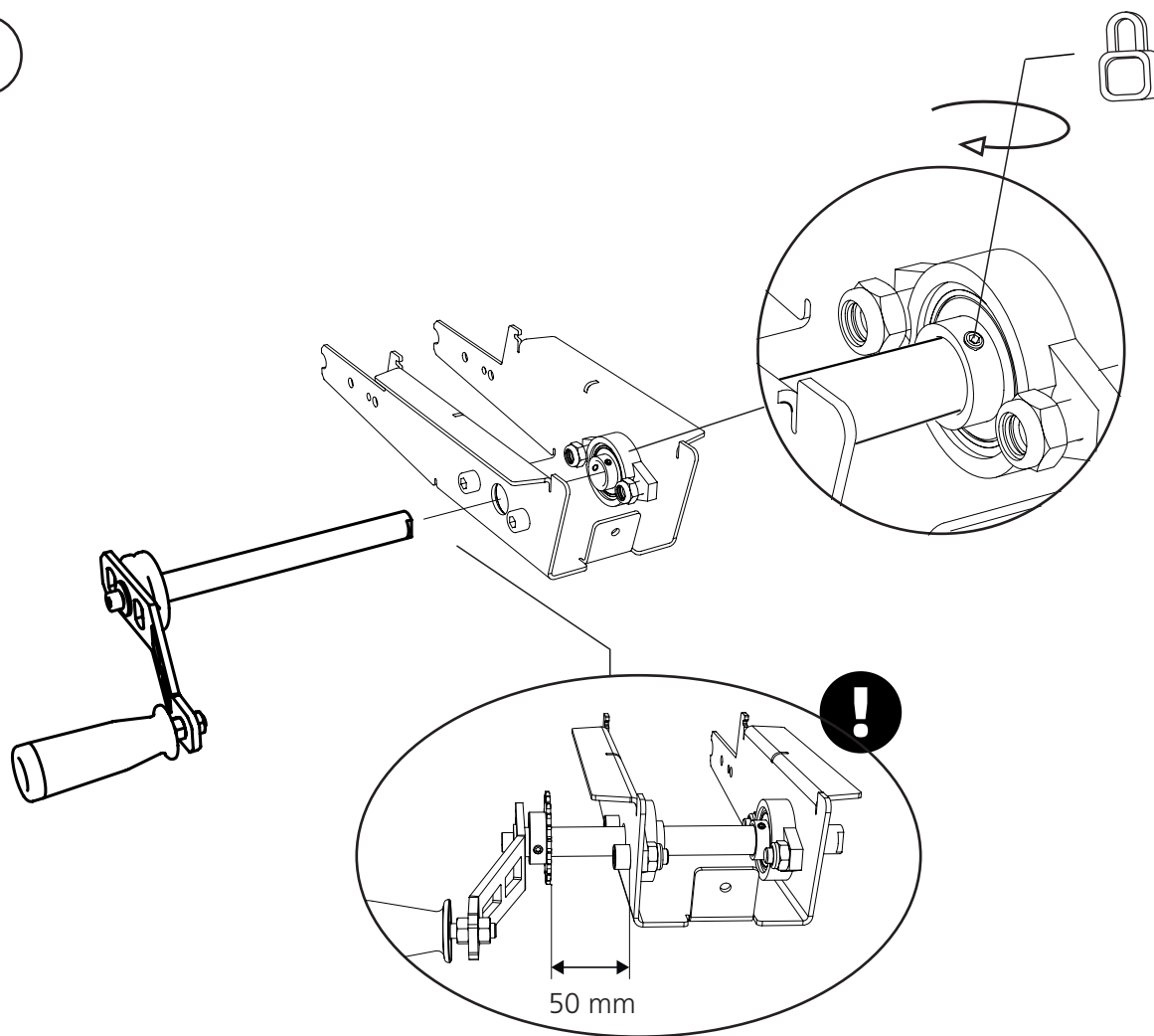

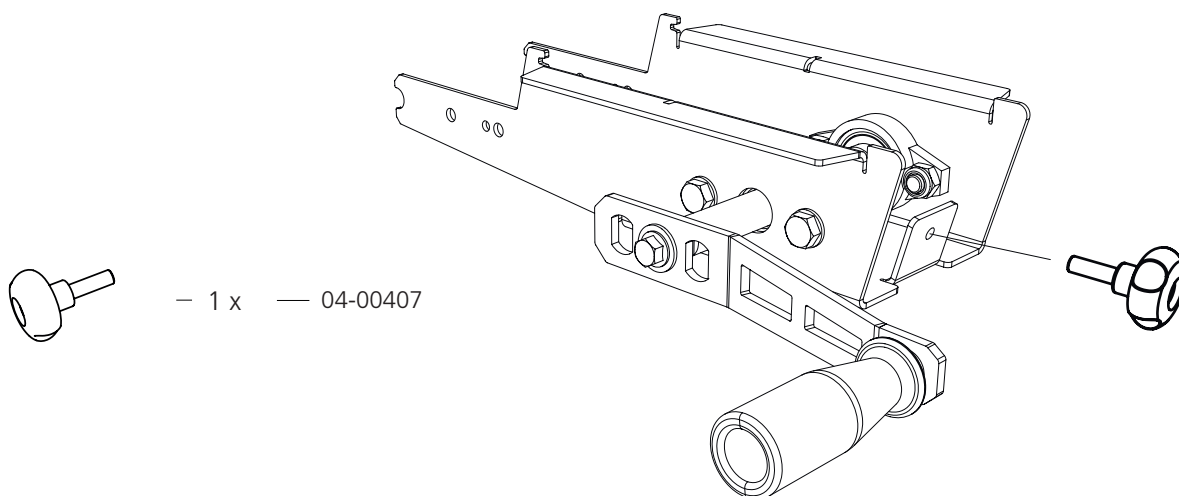

5



6

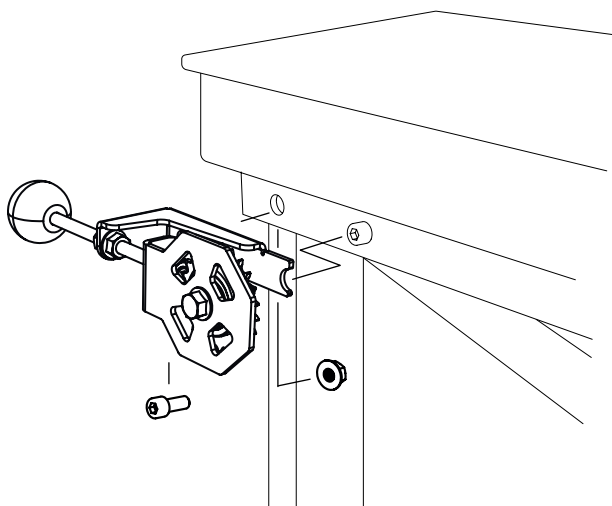

Montaż odbywa się częściowo z wykorzystaniem istniejących połączeń śrubowych szyny prowadzącej.

-  — 1 x — M8x20
-  — 1 x — M8



7

Montaż odbywa się częściowo z wykorzystaniem istniejących połączeń śrubowych szyny prowadzącej.

-  — 2 x — M8x20
-  — 2 x — M8

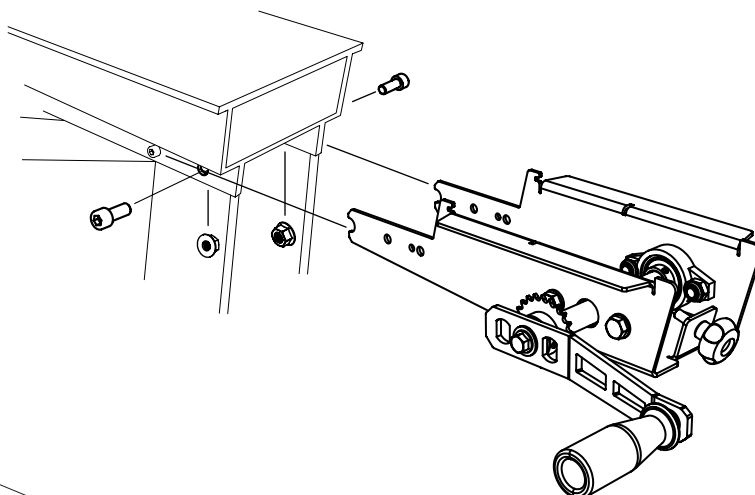

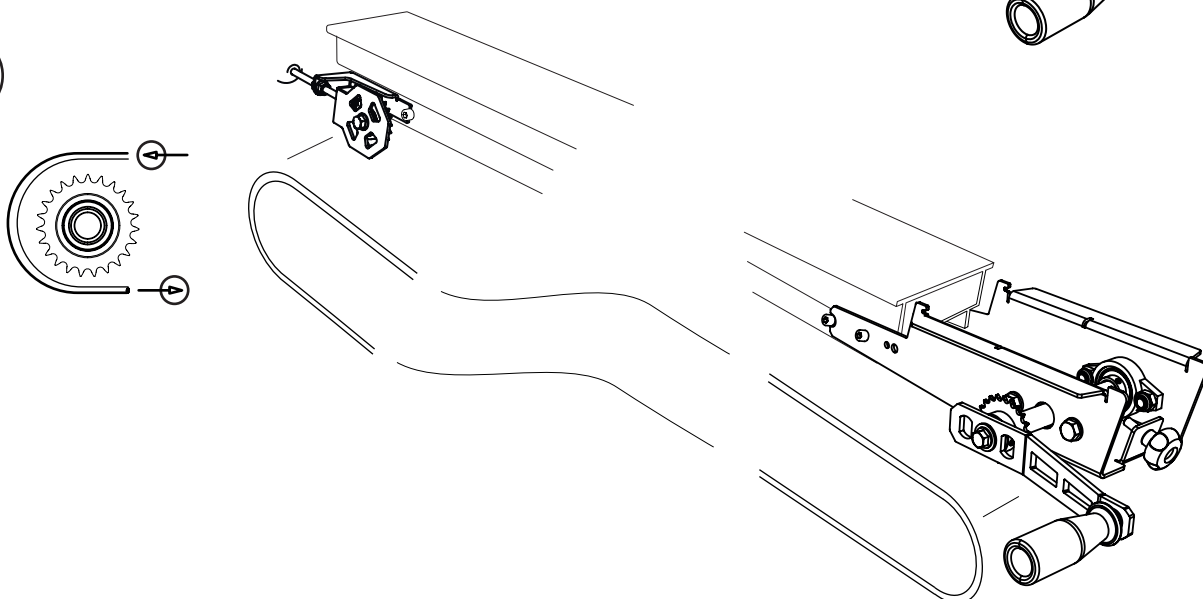

8



9



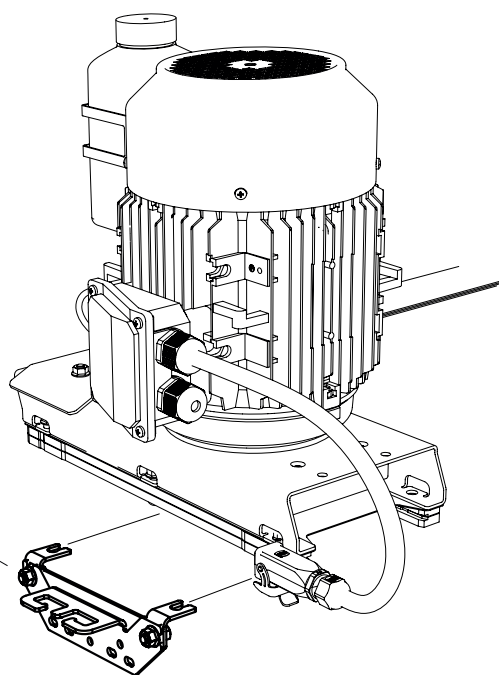
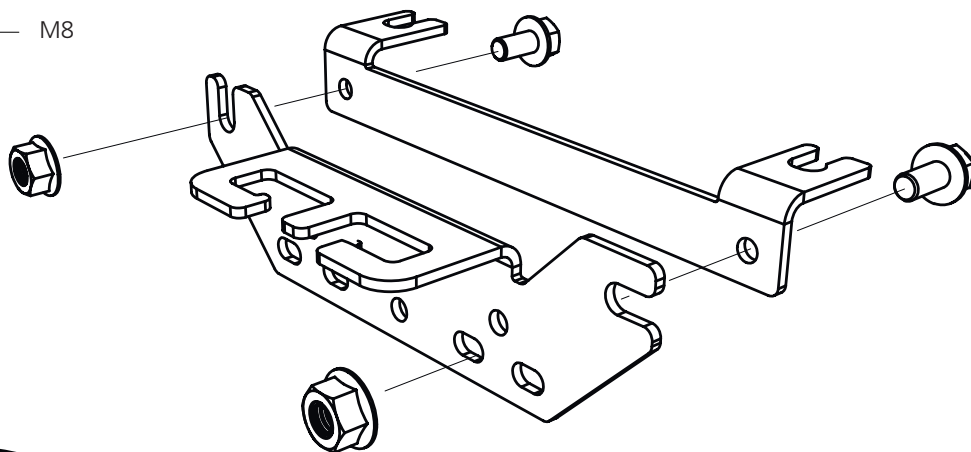

 — 2 x ————— M8x20

  — 2 x ————— M8



Montaż odbywa się za pomocą istniejących połączeń śrubowych sań do pilarki.

10

-  — 4 x ————— M6x16
 -  — 4 x ————— M6
 -  1 x ————— 01-00697, 4 m
 -  1 x ————— 01-00720, 1 m
 -  1 x ————— 04-00764
- Stosowane na każdy 1 m przedłużenia

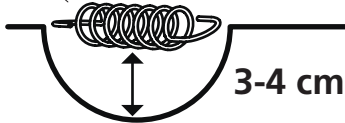
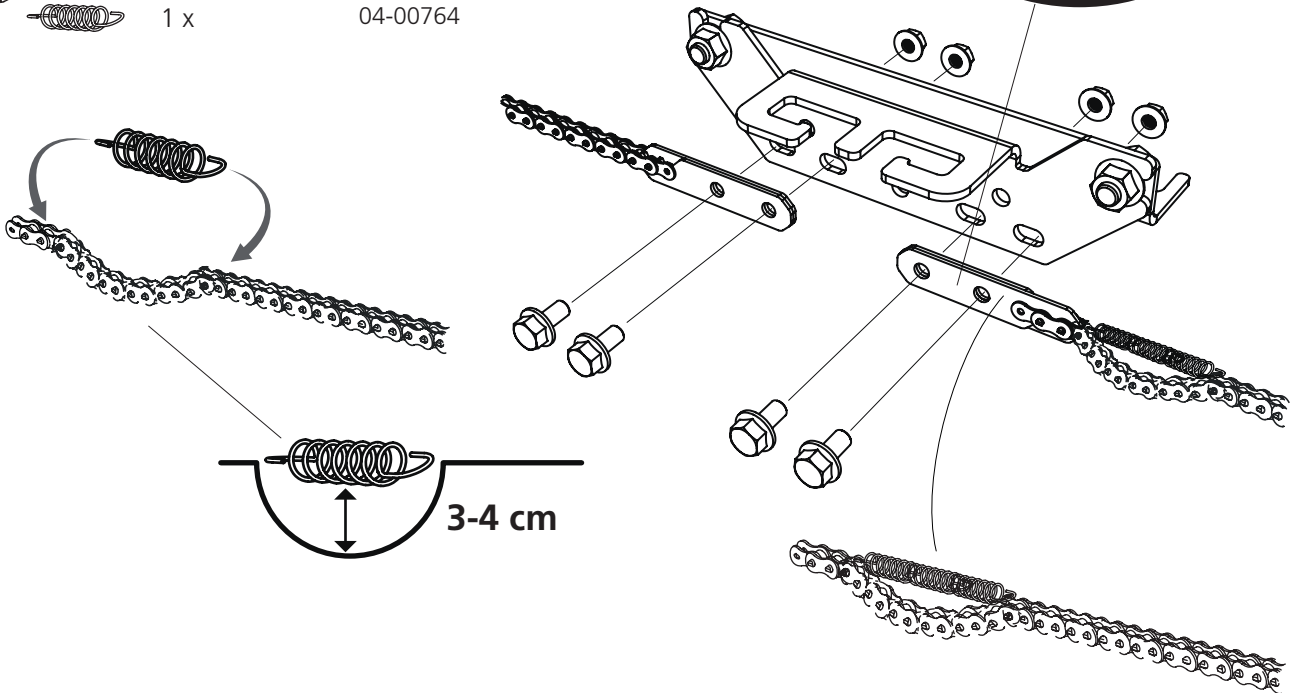
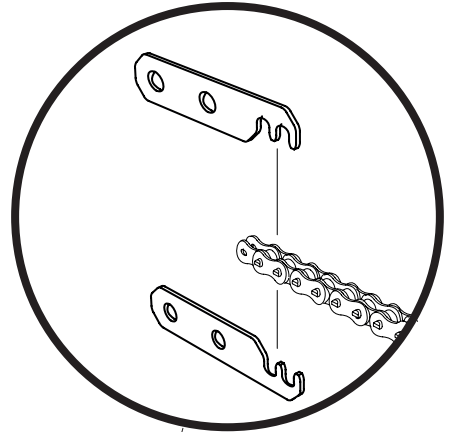

11

Napiąć łańcuch napędowy tak, aby pomiędzy łańcuchami było 6-7 cm.

W celu regulacji naprężenia należy zwolnić nakrętkę kołnierkową mechanizmu napinającego.

Po zakończeniu regulacji należy pamiętać o dokręceniu nakrętki kołnierkowej.

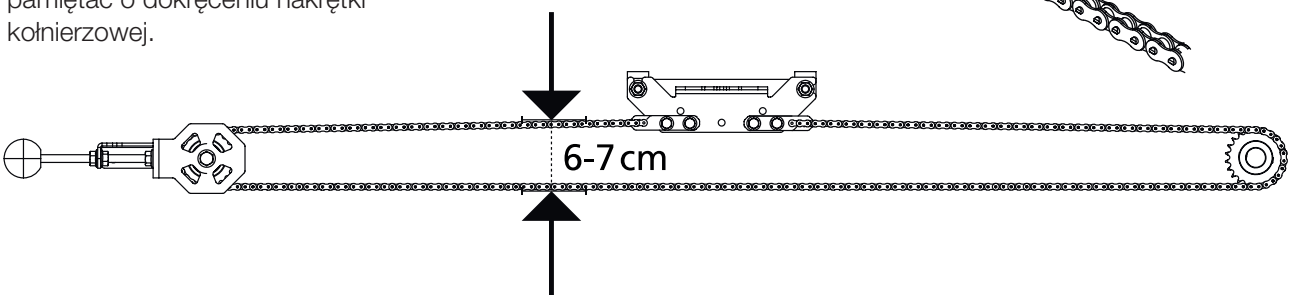
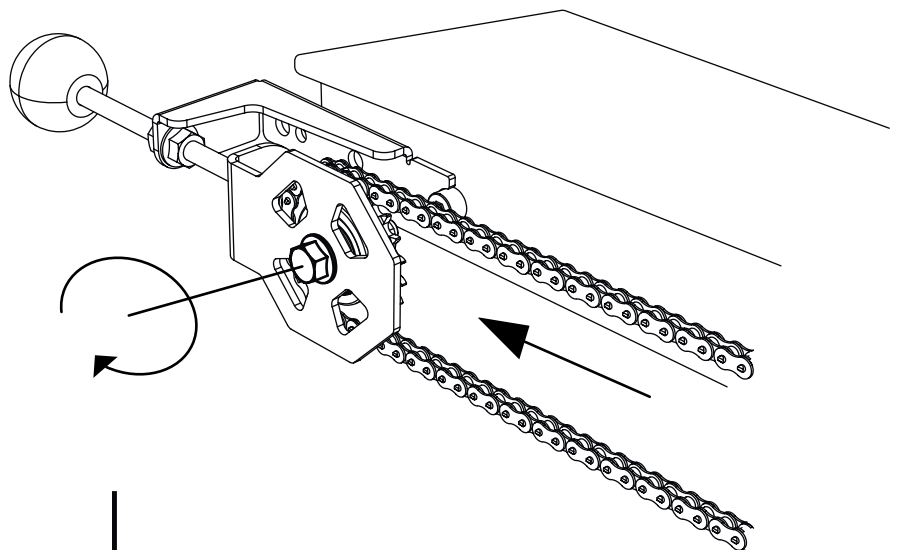



01-00804

12

Górną powierzchnię napędu zdalnego można zdjąć, aby umożliwić przechowywanie panelu sterującego z dala od traka, gdy nie jest używany.

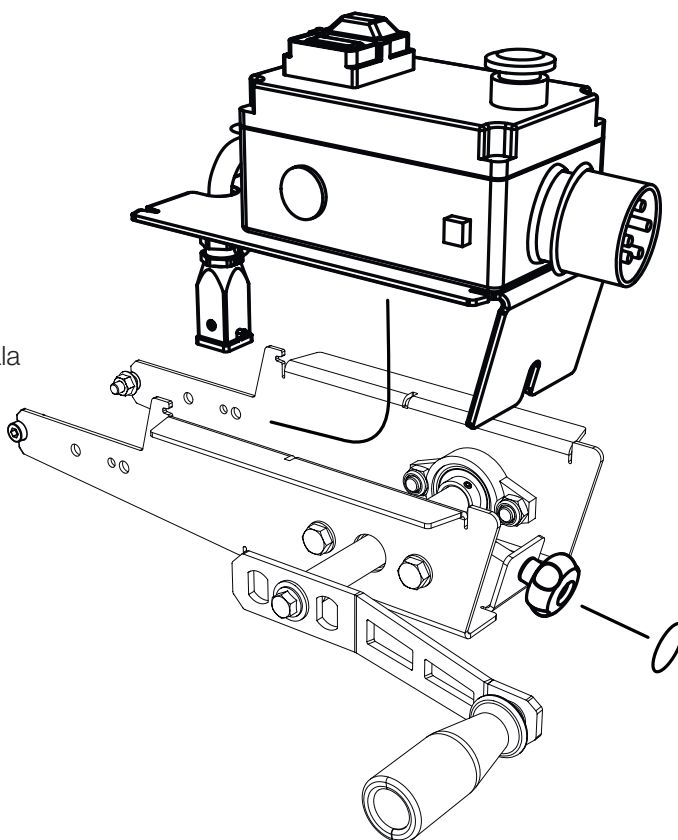

13

Przymocować przewód zasilający do zespołu piły w mocowaniu przewodu na płycie mocującej przewodu.

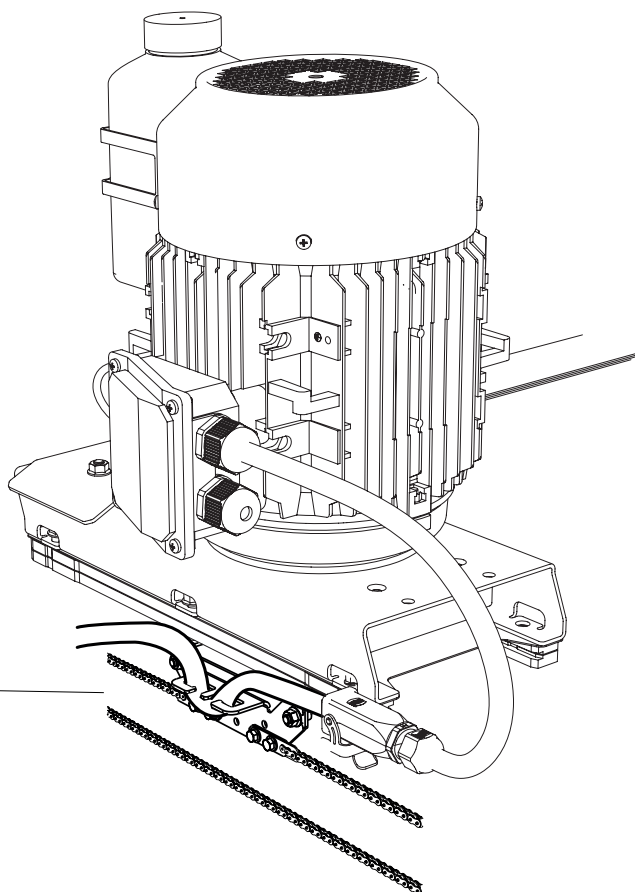
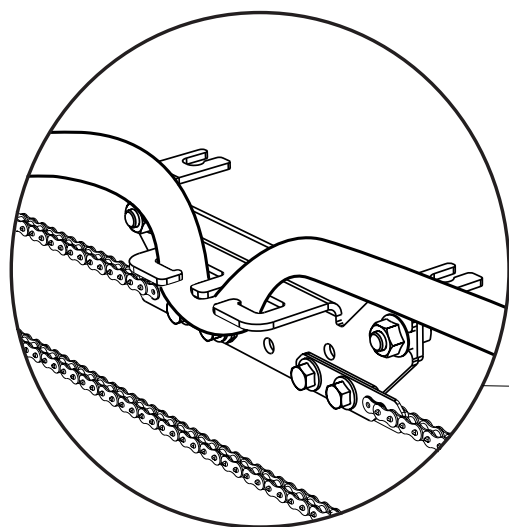



Deklaracja zgodności

Zgodnie z dyrektywą 2006/42/WE, załącznik 2A

Logosol AB,
Fiskaregatan 2,
S-871 33 Härnösand
Tel. +46 611 18285,

oświadcza się niniejszym, że **Zdalny napęd ręczny
do piły elektrycznej Logosol**

jest wyprodukowany zgodnie z: dyrektywą maszynową
2006/42/WE, dyrektywą EMC 2014/30/UE

i jest wyprodukowany zgodnie z następującymi
normami zharmonizowanymi:
EN ISO 12100:2010, EN 60204-1:2018

Härnösand, 26.06.2025 r.

Robert Berglund, dyrektor generalny

LOGOSOL

Arkiwägen 6, 871 53 Härnösand, Sweden
+46(0)611-182 85 | info@logosol.com | www.logosol.com