

 **LOGOSOL**



**From Log to Board  
with Your Band Sawmill**  
Helpful Tips and Advice

# ANYONE CAN CUT THEIR OWN BUILDING MATERIALS

## Easy to get started

You don't need any special training aside from the user manual to get started with a Logosol band sawmill. These mills are designed with precision engineering, solidly built to last, and loaded with features.

Our band sawmills work just as well at home as they do in the backwoods. They are portable and easy to set up right where the logs are!

You the customer are very important to us. Our goal is to make sure every customer is completely satisfied with their band sawmill. That's why we always provide a two-month money-back guarantee that allows you to take the sawmill for a test ride before making a final decision on purchase, along with a generous two-year warranty. We are also available by phone if you have any questions whatsoever.

Whatever you plan to use your sawmill for, we're confident you'll not only enjoy the ownership experience, but also find it to be a sound investment.

We hope that these tips and advice will be helpful.

**Good luck!**

**/THE EMPLOYEES AT LOGOSOL**



## Common Band Sawmill Uses

- Commercial custom-sawing
- Sawing large-diameter logs
- Sawing timber for houses, cottages & cupolas
- Sawing timber for garages and carports
- Sawing timber to replace cladding
- Sawing timber for a sawmill or lumberyard
- Sawing timber for work sheds
- Sawing timber for hunting blinds



# From log to boards with your **BAND SAWMILL**

## GET STARTED SAWING!

Most people that buy a band sawmill from Logosol get a lot of satisfaction from sawing their own lumber. You'll experience this wonderful sensation too when at the end of your first day on the job with your Logosol mill, you proudly look over the neat, orderly stack of wood that you cut with your own two hands. Just like tomatoes always taste better when they're plucked from the vine in your own garden, you'll enjoy that deck or rocking chair even more knowing it came from trees you felled yourself!

### **Your safety is important to us**

We place a lot of importance on safety when it comes to our machines. When you're working long and hard and handling logs and boards an accident can easily happen. Be careful and always use recommended protective gear!

### **Tips!**

- When unloading logs think carefully about where and how you plan to stack them. Once unloaded, they're very difficult to move to another location.
- A good sawbuck makes sawing a lot easier. Logosol has ready-made sawbucks, our so-called "Log Tables". You can also build your own made of logs or boards.
- When handling logs always use good tools and follow proper safety procedures. Logosol is a provider of several innovative tools, such as the Log Turner and the Mantis Arm. We also provide high-quality traditional tools, such as lifting hooks and log tongs, all available at [www.logosol.com](http://www.logosol.com)



## **BENEFITS OF THE LOGOSOL BAND SAWMILL**

- Includes the Logosol Peace-of-Mind Package. No need for anxiety as you'll receive not only a two-month money-back guarantee, but also a comprehensive two-year warranty with unlimited technical support.
- Easy to use. It's easy as pie to secure the log and set the board measurements.
- Where do you want to set up your sawmill? The B751 has a sleek form factor that can fit snugly in your own backyard!
- Reliability. It's extremely stable despite the compact form factor. You can saw logs accurately and without jarring vibrations.
- Adjustability and flexibility. The controls can be adjusted to fit your height, enabling you to work more comfortably and confidently.
- Upgradeable to suit your needs. A multitude of extensions and sawdust management systems are available as accessories.
- Ideal for stationary set-up.
- Log moulders available as an accessory.
- Logosol is a reliable and experienced company, established in 1989. We care about our customers and will do our utmost to assist you and exceed your expectations.



# From log to boards with your **BAND SAWMILL**

## SAWING TIPS FOR LOGOSOL BAND SAWMILLS

The following provides an example of how to cut logs with a horizontal band sawmill. The goal is to end up with boards or planks that bend at the surface instead of the sides when sawing a log that isn't completely straight.

### Positioning the log for sawing:

- The top end of the log should be on the sawhead side.
- Any arcing or bowing in the log should be placed either opposite or facing the log support.
- In the picture below the log's positioned so the bowed section is facing away from the log support.



### Step 1. Taking the first cuts

- Use a Logosol Toe-Board Log Lifter and adjust the top end of the log until the centre of the log (the heartwood) is parallel with the log bed.

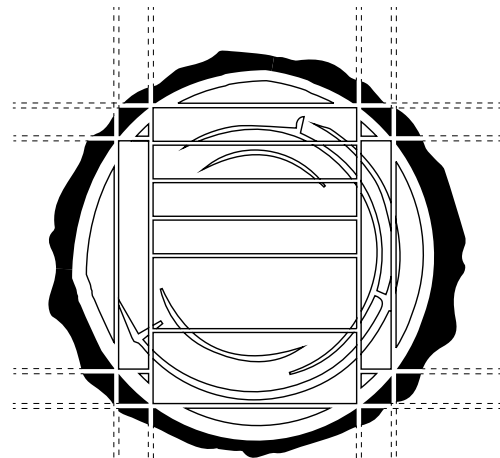
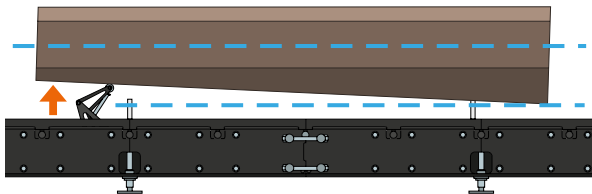

### Sawing a cant

- Cut away a slab and, if necessary, a board (1a).

- When sawing a large diameter log you can cut several rough-edged boards before turning it over (1b).

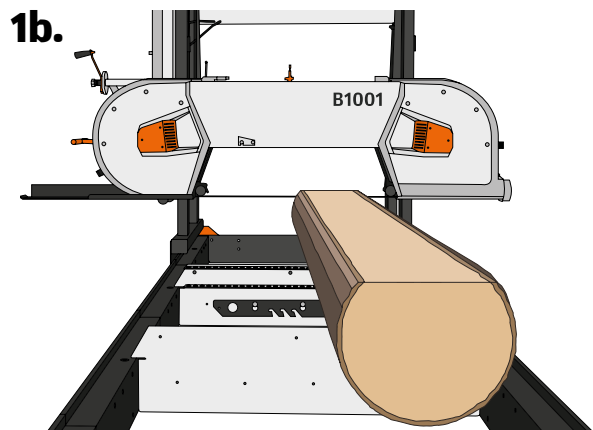
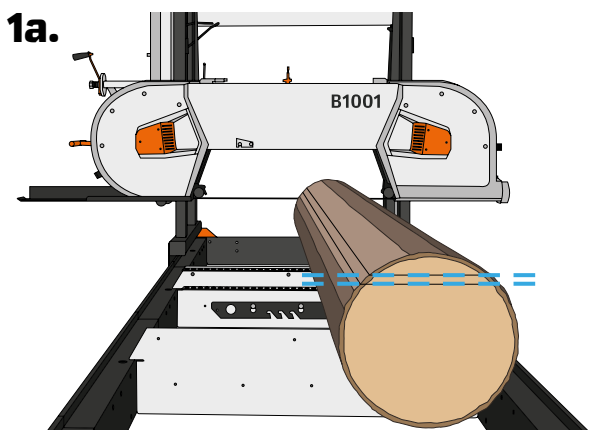

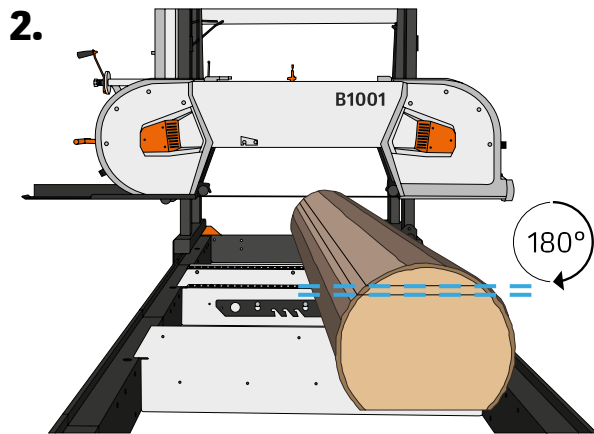

## Step 2. Cutting the other side of the log

- Turn the log 180 degrees so the side you just cut is facing down on the log bed.
- Cut a slab and one or more rough-edged boards. These cuts will determine the width of your board.

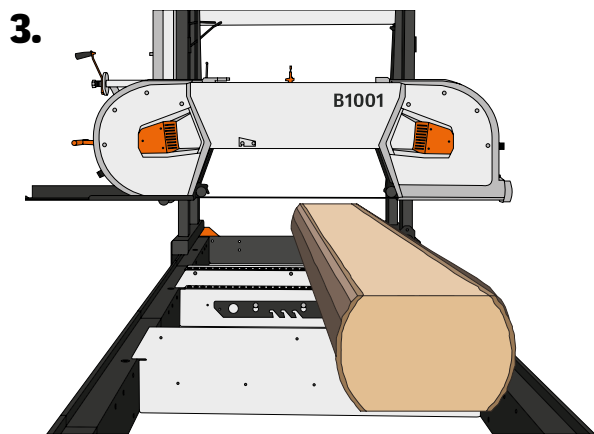

## Step 3.

- Here we've cut two slabs and two boards.
- The cant width (the width the next boards will have) has now been set.

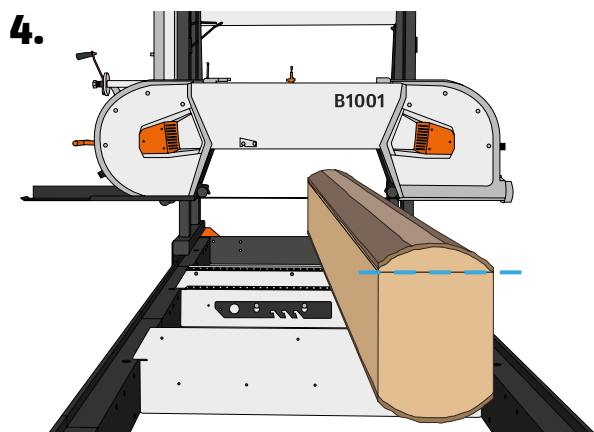

## Step 4. Cutting the third side

- Turn the log 90°.
- Use a LOGOSOL Toe-Board Log Lifter and adjust the top end of the log until the centre of the log (the heartwood) is parallel with the log bed.

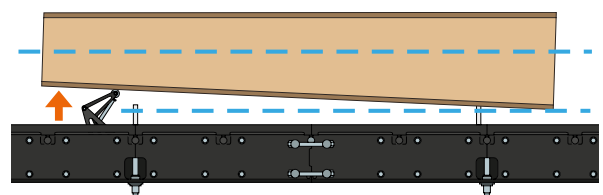

# From log to boards with your **BAND SAWMILL**

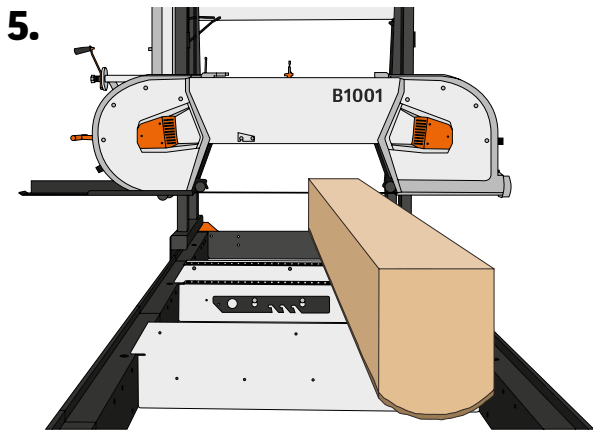

## Step 5. Cut away the slab

- Make another cut and lift the slab away.

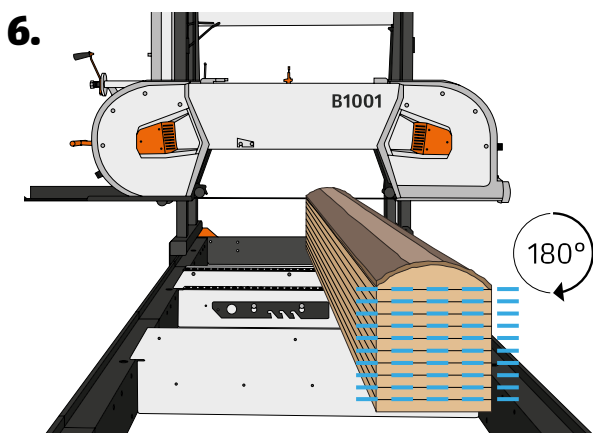

## Step 6. Cut planks and boards

- Turn the log 180 degrees and secure it with the flat side facing down.
- Decide what you want to get out of the remainder of the log and make sure your calculations are correct. The scale on the band sawmill shows where you should start your first cut.
- Be careful not to cut into the log supports.
- Lower the log supports completely and fold up the clamps.
- Then, slice the entire log into boards or planks in the measurements you require.

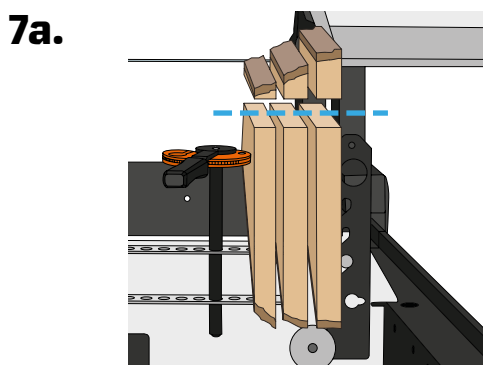
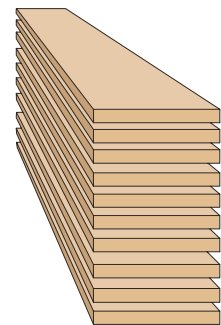

## Step 7. Edging the boards

- Place several boards together if you want them to have the same measurements.
- Use a LOGOSOL Toe-Board Log Lifter and adjust the top end of the board until the centre of the board (the heartwood) is parallel with the log bed.
- Cut off the edges of the boards (7a).
- Turn the boards 180 degrees and decide what width you want, then cut off the edges on that side (7b).

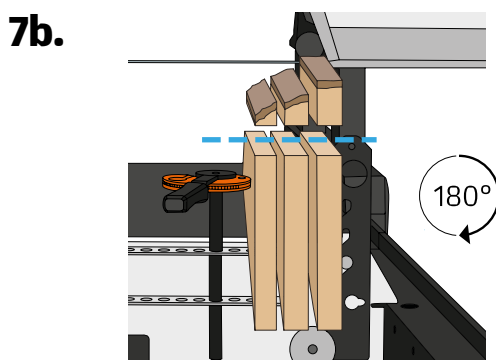

### Tip!

With Logosol's C210 board edger (SKU: 5220-000-1000) edging the boards goes even faster! Read more at [www.logosol.com](http://www.logosol.com)

## TWO OTHER SAWING METHODS

### THROUGH-AND-THROUGH SAWING

Sometimes it's better to slice the timber in rough-edged boards.

This way you can get a little more out of each log. The price for this efficiency though is that it takes a little more time. With nicer carpentry-grade logs it can help to edge just one side before they're dried. The final edging is done once you know what the piece will be used for. The goal is to be able to use as much as possible of the log.

When you are going to slice up a log it's a good idea first to saw off a thin slab and then turn the log over so it rests on a level surface. This ensures that the log doesn't move around between the cuts and you get nice boards of even thickness. Turn the log when you are getting close to the middle of it.

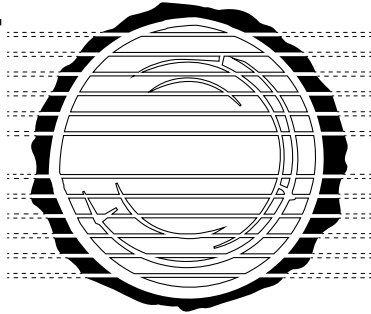

### QUARTER SAWING

You'll get the nicest lumber if you quarter saw. You'll get the optimal grain direction in all boards, which is a huge advantage in, for example, furniture making.

The disadvantage is that it's time-consuming and difficult, and you end up with several different widths of lumber. Quarter sawing shouldn't be attempted on logs that are too small.

Start by sawing the log in the middle, but don't saw all the way through. Turn the log 90° and this time saw all the way through it. Then just break the pieces apart so you get four quarters.

When you saw boards, flip the bit after each cut. Sometimes it can be easier to saw from underneath the log. Then you're able to maintain the sawhead at the same height the entire time.

Many of us at Logosol have years of experience sawing wood. As a new Logosol customer, if you have any questions, you are more than welcome to ring us up on the dog and bone. We would be delighted to provide you with helpful advice.

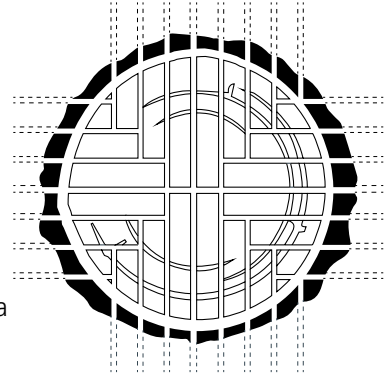

### Tips!

- When you've secured the log on the sawmill, make sure the band blade can't cut into the log supports and that nothing else is in the way before you start sawing.
- Don't pull the saw carriage back as long as the band blade is moving. It can lead to the blade being forced off the pulleys and sustaining damage or damaging other equipment.
- Try to keep the pith parallel with the track you're cutting into the log when you saw. If the pith is in the middle of a board or plank, cracks will develop on both sides surrounding it when the board or plank dries.

To turn over the piece of timber in the saw you can use a two-handed log spinning cant hook, such as the one pictured, **Logosol's Smart Turner (SKU: 9999-000-2702)**



## WOOD - A LIVING MATERIAL

Wood is a unique material in many ways. We have thousands of customers around the world using this incredible natural living material to realise their visions and dreams!

### The Advantages of Wood:

- Durable and long-lasting - wood construction lasts for many generations.
- Pliable - a fantastic material to work with.
- Relatively inexpensive.
- Environmentally-friendly - saves energy and promotes conservation when you fell the timber yourself and leave room for new growth in the forest.
- Stylish - wooden structures and furnishings never go out of style!

## WOOD - A LIVING MATERIAL

Wood is also a living material. A fresh-cut tree contains large quantities of water. Within the outer rings there can be more water than wood. You can even see this in the boards you cut from the outer periphery of the log.

This causes the tree to shrink and change shape when it dries.

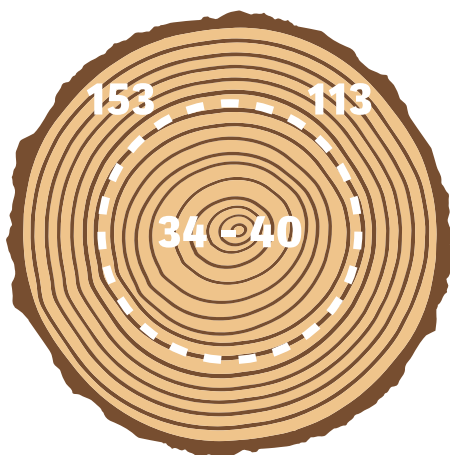

## STRESS IN THE WOOD

There is always stress in wood that's in the process of drying. A lot of times you won't notice this, especially if you're sawing freshly-cut wood in which the drying process hasn't started. There are certain factors that can cause wood to contain more than the usual amount of drying stress, such as a tree growing on a slope or near the edge of a forest that develops a multitude of branches on one side. The tree compensates for this by growing more fibers to support itself.

Regardless of the sawing method used, drying stress is a real problem both during the actual sawing and the drying and processing of the wood that follows.

Here's how to discover stress in the wood: When you pull the saw back over a fresh cut in the wood, watch how the blade runs along the newly-cut surface. If there's a gap or it encounters resistance, then there's stress in the wood.

### Avoid the Effect of Stress on Wood

- Saw wood when it's freshly cut.
- Saw the log gradually from all sides.
- Saw the last plank with a recently-cut block beneath it or use a log support.
- Saw the smallest logs possible when the wood is stressed.
- If you run into a log with extremely high stress, it's safe to assume it'll produce crooked, twisted planks regardless of the sawing method used. Fortunately, these kinds of logs aren't typical.

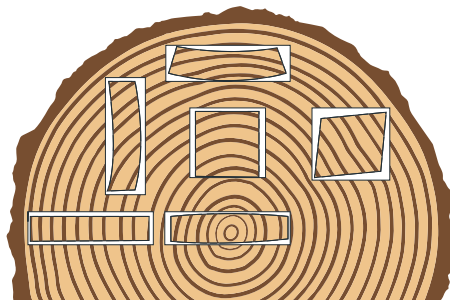

*How much wood shrinks varies among the different varieties of trees and trees may dry differently depending on where they were located in the stand.*

## BUILD YOUR OWN HOME WITH THE LM410 LOG MOULDER

The LM410 Log Moulder and Beam Planer even works as a planer and jointer for beams up to 600 mm in width. Available both for petrol and 3-phase electric motors. The cutting width is adjustable and fits most timber band saws, such as Logosol, Norwood, Wood-Mizer, Solidsaga, and Lennartfors. Choose among dozens of designs in the Logosol tools catalogue!

Building a vacation cottage that can withstand wind and weather and provide joy and comfort for generations to come is an extremely rewarding project.

### The LOGOSOL Log Moulder - the Best Choice!

- Log moulder and beam planer all-in-one!
- Available with automatic feed.
- Unlimited choice of blades. Logosol's log moulder takes log house knives, planer knives, and profiles for rounded corners, curves, and hundreds of other shapes. See our handy tools catalogue for a plethora of choices and inspiration!
- Easy to attach a dust extractor.
- Lightweight and stable construction.
- Very economical.
- Compatible with most band saw models.



## **BUILDING WITH FRESH-CUT WOOD**

If it's possible to build with fresh-cut wood, you should absolutely do so. You'll save a lot of time. Fresh-cut planks and boards are often straight as an arrow and won't change their shape when used in a structure. Bridges, outdoor stairs, and fences are natural applications for fresh-cut wood. Non-insulated buildings and storage sheds are ideally suited for building with wood sourced directly from a sawmill. If the building is supposed to be insulated, then you need to wait until the structure has dried. During the spring this only requires a few days of nice weather. Logosol's in touch with many customers who use fresh-cut wood. It's been our experience and theirs that shrinkage of the wood seldom creates a problem. The important thing is to not place the wood where it's unable to dry.

Certain structures can therefore be built with undried wood, but you should keep in mind that the wood will shrink about 5% in height and width. The wood also shrinks about 0.3% in length, but you can usually just ignore this. However, be careful not to hammer in two nails right next to each other near the end of a board,

especially soft panel boards. They can split in the middle. Instead, hammer one nail in first, and wait on the other until the wood's dried. To avoid rot you shouldn't build with raw wood in which air can't circulate adequately.

An example of when to use raw wood is when you build a log cottage. It's advantageous if the walls are heavy and the logs still pliable so they fit together snugly.

### **Typical Projects for Fresh-Cut Wood:**

Non-insulated buildings or buildings to be insulated later once the wood is dry.

- Log Cottages
- Bridges
- Outdoor structures, such as stairs and fences



## MEASURING THE MOISTURE CONTENT

The moisture content in a material can be described by its moisture quotient. The moisture quotient is the relationship between the weight of water and the weight of dry matter in a material.

The moisture quotient can be determined by weighing a piece of wood and then drying it completely and weighing it anew.

### MOISTURE METERS

Logosol sells a common type of moisture quotient meter that measures the electrical resistance between two metal pins that are pressed into the wood. This type of meter provides a direct reading. (SKU: 0464-802-0010)



## DRYING FOR USE IN CONSTRUCTION

The most common method when using a band saw is to air-dry the wood by stacking it in layers on top of spacers (called "stickers") outdoors (preferably under a roof) and letting it sit outdoors for several weeks in the spring. An old rule of thumb is that wood that's dried in this manner should be ready by mid-summer.

When the wood is dry enough for construction (around 18% moisture content), it can be used straight away, even in building structures that are going to be insulated. It's also easily planed. When the wood is this dry, you can even store it indoors.



## DRYING FOR USE IN CARPENTRY

If the wood is to be used for fine carpentry, then it should be kept in a heated location an additional 3-4 weeks or dried in a wood kiln to get that perfect result.

When the wood is adequately dry (8-10% moisture content), you can use it for furniture making and other types of carpentry. If you want to dry your wood quickly, LOGOSOL can help you find the right model of kiln. When you're planning your sawing, you can easily plan to stack the boards in layers and let them dry outdoors, then take them indoors and allow them to sit for a year or longer, depending on the type of wood.

Most recreational carpenters allow wood to dry at room temperature, which takes several months.



The denser the wood, the longer the time required. Boards generally become dry enough for carpentry after several weeks in a warm, ventilated location.

# From log to boards with your **BAND SAWMILL**

## DRYING IN A KILN

If you have the time, an old reliable method is to allow the wood to dry on its own. Another method is to dry it in a kiln. The WDU (SKU: 6200-000-0000) from Logosol gives you energy-efficient drying and perfect results.



With the WDU you can dry pine so it's ready to plane in a week. You get quick results with less cracking and warping compared to air drying. Sauno kilns have been on the market for over 20 years and are now a proud part of the Logosol product line.

The end result is bone-dry wood with less cracking and warping compared to air-dried wood. But the biggest benefit is the time savings. That can vary depending on the type of wood and desired moisture content. For example, you can dry conifers from 17% to low enough moisture for use in furniture production in a week. Fresh-cut spruce can be dried to where it's ready for planing within 7-10 days. By building the cabinetry yourself, you can keep your costs lower.

## AIR DRYING WOOD

Wood can usually be dried outdoors if it's protected against sun, rain, mud, and ground moisture. Stack the boards with spacers in between and stabilise them so they don't sag or twist - ratchet straps work great.

### Tips for Stacking in Layers

- Typical measurements for spacers are 25 x 38 mm
- The spacers or "stickers" should be dry to avoid fungal infestation between the wood and the spacers.
- It's important that the spacers run all the way out to the ends of the boards to prevent cracks from developing.
- The spacers must be laid directly on top of each other in each layer so pressure's transferred from spacer to spacer all the way down to the foundation. Careless stacking can lead to severe deformation once the wood is dry.
- Placing the pith side up when stacking helps increase the stability of the stack.
- Weights are placed on top of the stack to prevent deformation.

## Checklist -Do You Need to Dry?

### Woodworkers and carpenters

- Do you need wood dry enough for furniture making?
- Do you want to avoid having your fine carpentry crack or break after being made?
- Are you able to get a hold of a few "odds-and-ends" of wood for your carpentry?

### Mini-mill operators

- Do your customers want wood with less than 18% moisture content?
- Do they want short delivery times?
- Should the wood have an even moisture content?



- The foundation should be started a fair distance from the ground (ca. 20-30 cm) so air can circulate under the stack.
- Use 5-9 spacers in each layer.

## Tips from "From Log to Cottage"

In the book "From Log to Cottage", the author Sven-Gunnar Håkansson describes an intriguing way to dry and load a layered stack of wood.

- Lay the planks end-to-end on top of the pile centred over each spacer.
- Place a layer of slabs on the planks with the sawed-on sides facing up.
- Lay plastic sheeting over the slabs.
- Add more slabs on top of the sheeting.



## GUIDANCE TABLE FOR DRYING

Since wood shrinks when it dries, you should saw off larger pieces than needed when it's fresh. You can count on some variances from the norm. The examples in the table below provide some guidance.

<b>Size of the dried timber (ca. 20% MC) (sanded with a LOGOSOL plane)</b>	<b>Size of the raw wood</b>	<b>Potential Areas of Application</b>
16 mm	19 mm	16 mm exterior panel 12 mm panel
19 mm	22 mm	19 mm exterior panel 14-15 mm panel
22 mm	25 mm	22 mm exterior panel
25 mm	28 mm	21 mm floorboards
32 mm	36 mm	28 mm floorboards
38 mm	44 mm	36 mm cut timber 14-15 mm panels (split in two with a KS150)
44 mm	50 mm	19 mm ext. panels (split in two with a KS150)
50 mm	55 mm	48 mm cut timber
63 mm	68 mm	Split into 21 mm floorboards
75 mm	82 mm	73 mm cut timber 14-15 mm panels (Split with a KS150)
100 mm	107 mm	98 mm cut timber
125 mm	132 mm	
150 mm	157 mm	
175 mm	182 mm	
200 mm	207 mm	
225 mm	233 mm	



## DO IT YOURSELF IDEA - BUILD A BENCH



The transformation from raw timber to a finished bench takes around an hour. Use a chainsaw, a yardstick, a carpenter's square, a hammer, and nails. No need to be a nervous Nelly - it will turn out just fine!

### List of materials

Diagonally cut 51x178 mm:  
2 - 185 cm boards, 2 - 35 cm boards

32x178 mm:  
1 - 140 cm board, 4 - 35 cm boards

### Instructions

Draw a curve in the 140 cm long board (e.g. by attaching a pencil to a 150 cm long string and attach the other end of the string 142 cm from the centre of the board). The curve should extend to around half of the width of the board. Cut along the line with a chainsaw, band saw, or jigsaw.

Nail two of the legs (A) into the arched support board. Make sure the support board doesn't stick out from the legs. Mark the middle of the short, diagonally-cut boards (B) and nail them into the legs in the middle of the support board. Let the diagonally-cut piece stick up about 3-4 mm above the leg boards and support board.

Nail the other two legs (C). Cut the leg boards with the chainsaw in a straight line (D) between the short, diagonally-cut board's upper corners and the lower corners of the legs. Put on the long, diagonally-cut boards (E) and nail them into the short diagonally-cut boards at 1 cm intervals.

Finally, carve off all rough edges with a sharp knife.

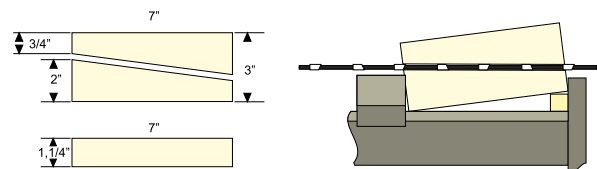

To make the two diagonally cut boards: Saw a 51mm x 178mm board and cut it 221 cm in length. Split it diagonally by placing a 25mm high moulding under the board's inner edge. The sawmill should be set at 2" (5 cm). In addition to these boards, a 32mm x 178mm (285 cm in length) is needed.

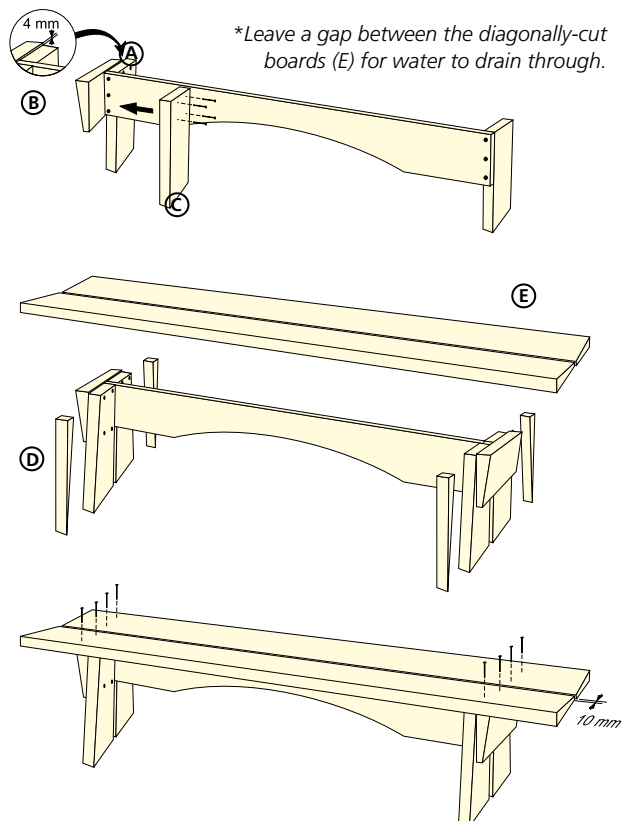

## MORE INFORMATION

### Handbook for Your Chainsaw

Everything you need to know to properly use your chainsaw's bar and chain for perfect results. Download for free at [www.logosol.com](http://www.logosol.com) or give us a ring at +46 611 182 85 to order it.



**The Handbook for Your Guide Bar & Chain**  
Care Instructions and Tips

### From Log to Cottage

Sven-Gunnar Håkansson has written a fantastic book on how to saw your own wood and build a cottage. Highly readable, the book may be ordered from LOGOSOL, but is also available in many bookstores.



Visit [WWW.LOGOSOL.COM](http://WWW.LOGOSOL.COM) to see our entire product range:



Sawmills



Planers



Joinery



Accessories



Spare parts



Cutting tools



More products

**Be first to get our best tips and offers!**  
Follow us on social media. >>

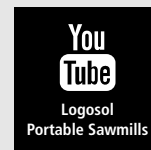
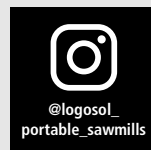
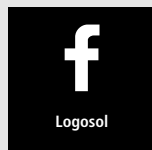

# LOGOSOL

**LOGOSOL AB (HQ)**

Fiskaregatan 2, SE-871 33 Härnösand, SWEDEN

Phone: +46 611 182 85 | [info@logosol.com](mailto:info@logosol.com)

[www.logosol.com](http://www.logosol.com)