

USER MANUAL

TRANSLATION OF ORIGINAL USER MANUAL

0458-395-5461

REV: 2

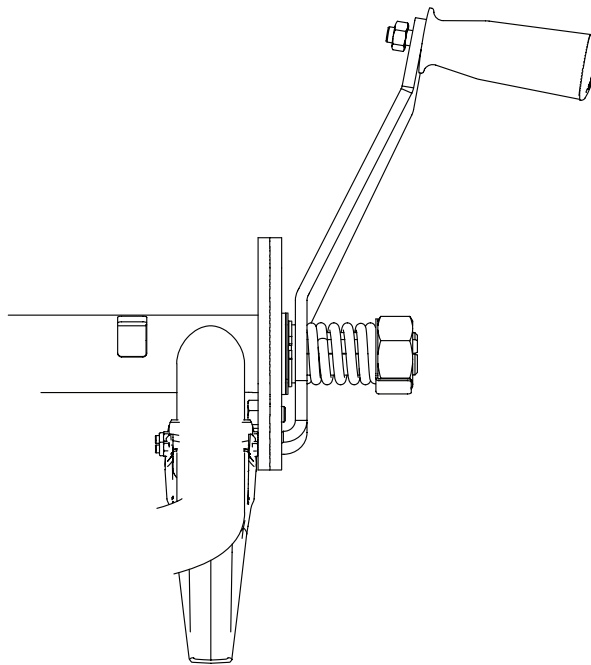

MANUAL CRANK LEVELING



Read through the user manual carefully and make sure you understand its contents before you use the machine.



This user manual contains important safety instructions.



WARNING! Incorrect use can result in serious or fatal injuries to the operator or others.

BOLTS & NUTS

Definition of fasteners on following pages.

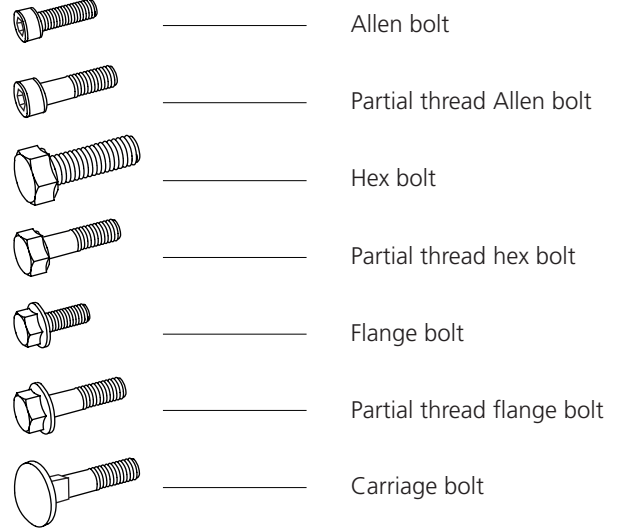
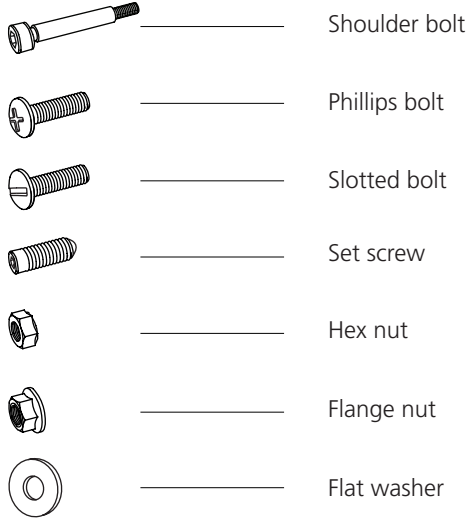

ADDITIONAL SYMBOLS

The following symbols are used as supplements to the symbols above to describe the design or function of the fasteners.



DIAMETER & LENGTH

The size of a fastener is written as a diameter measurement **(M)** ISO 68-1. For bolts, this is followed by a length measurement. The length of the bolt is measured from below the head to the tip of the bolt.

(Diameter) **(Length)**
M8 x 20



When this symbol appears during assembly, parts must be lubricated before installation. Lubricate affected parts with universal grease.



This symbol describes the recommended lifting point for heavy lifts.



This symbol describes the sawing direction and reappears during assembly.



Screw the joint finger-tight.

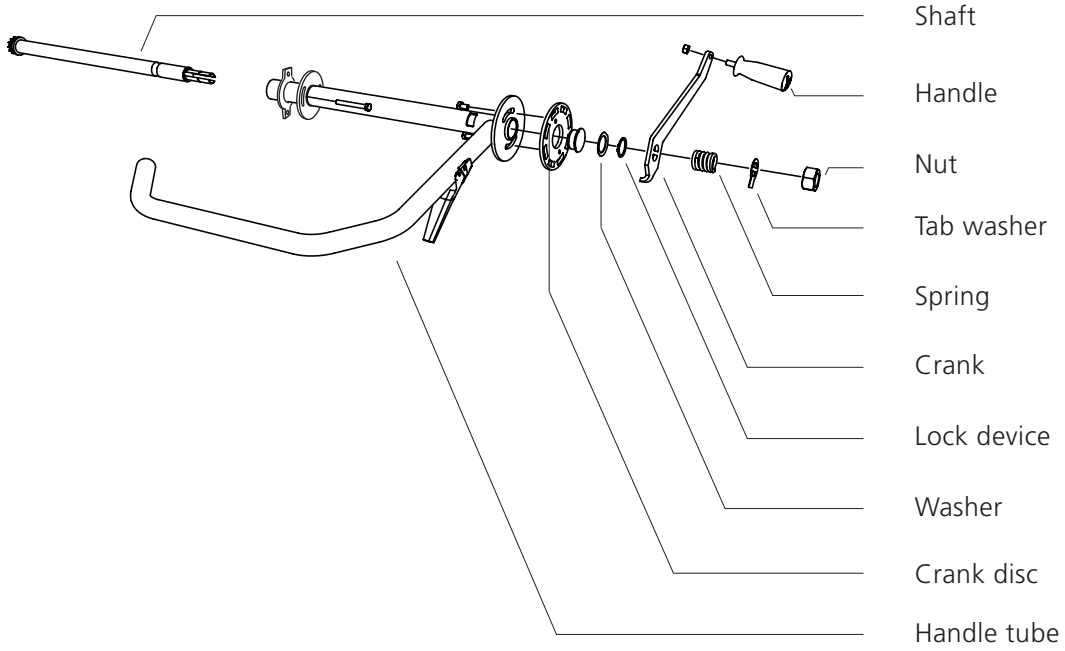
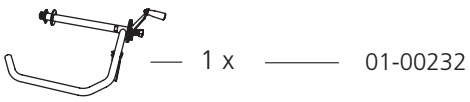

MOUNTING THE HANDLE

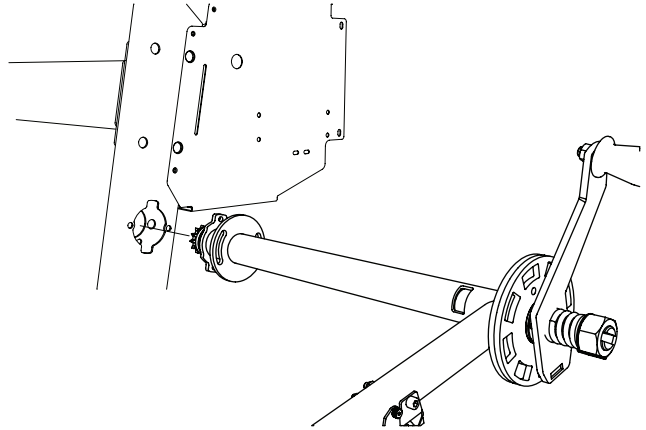

Fit the tube handle in the rear carriage leg.

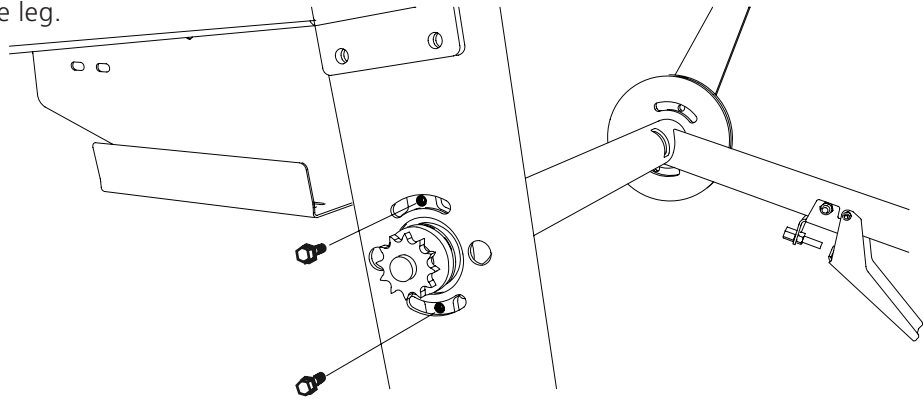

Secure the tube handle with the short fixing bolts.

 — 2 x — M8x16

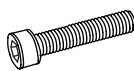

Secure the tube handle with the long fixing bolts. Note that the inner nut should be placed so that the head of the Allen bolt is flush with the surface of the carriage leg.

Use the pre-fitted screws for this assembly.

 — 2 x — M8x60
 — 2 x — M8
 — 2 x — M8

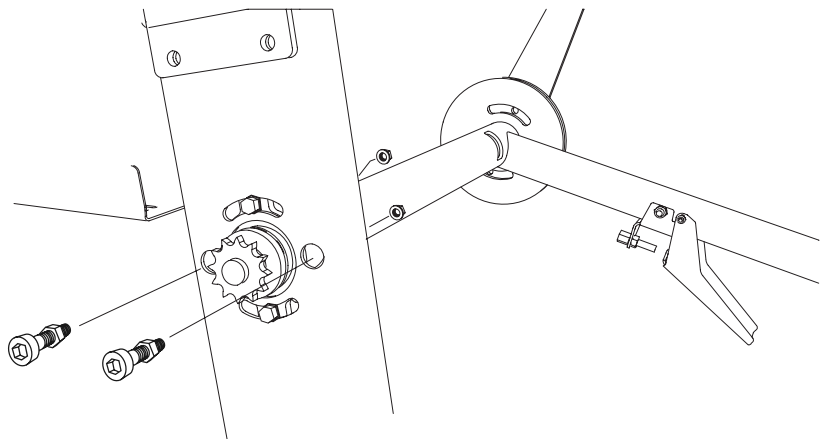

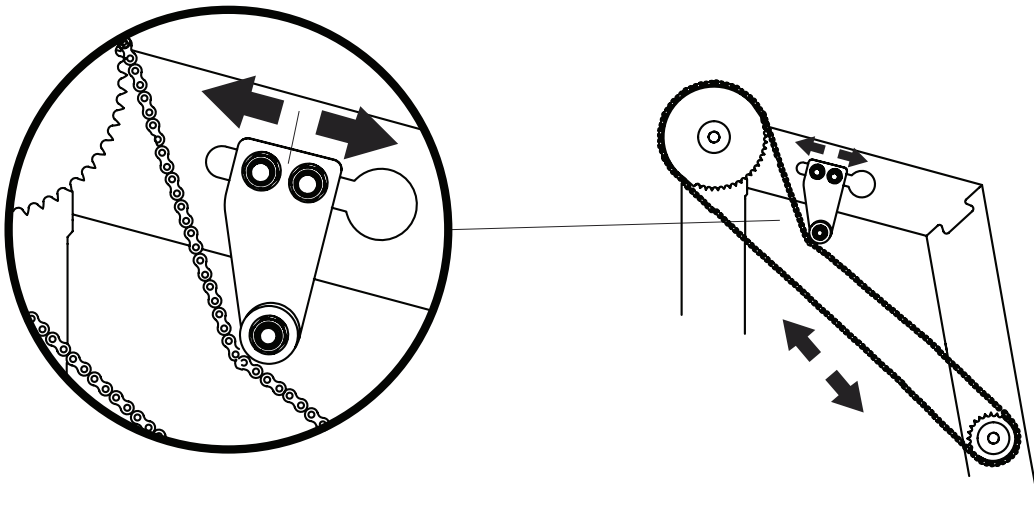

ADJUSTING THE CRANK

To ensure that the scale on the sawhead crank works correctly, it has to be calibrated. This is done by lowering the sawhead to its lowest position and then loosening the adjusting plate of the crank. Now, raise the sawhead until the pointer in the crank tube is aligned with a number on the crank scale. It does not matter what number it is, as long as it is aligned with the pointer. Then, tighten the bolting. Finish the adjustment by turning the adjusting bolts on the chains until the sawhead rests on the stops in the front legs of the sawcarriage. Be careful to adjust exactly equally much on both sides to keep the blade parallel to the bed.

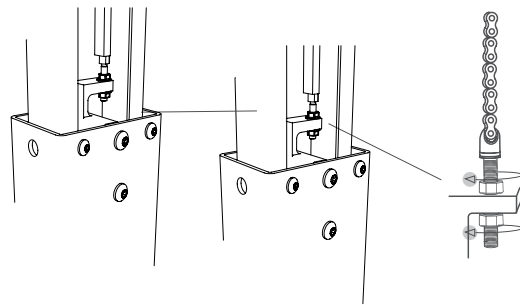
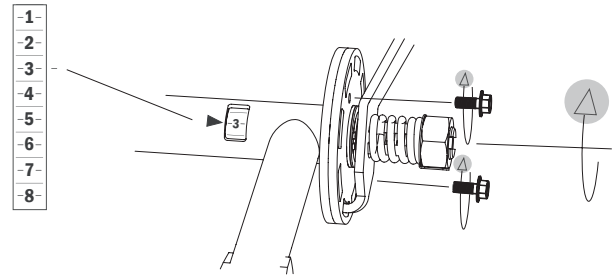

SET THE CRANK SPRING

Tighten the lock nut in order to tension the spring so that the handle snaps back easily and locks in the crank pulley. When the handle is working properly, bend the lock washer to secure the lock nut in position.

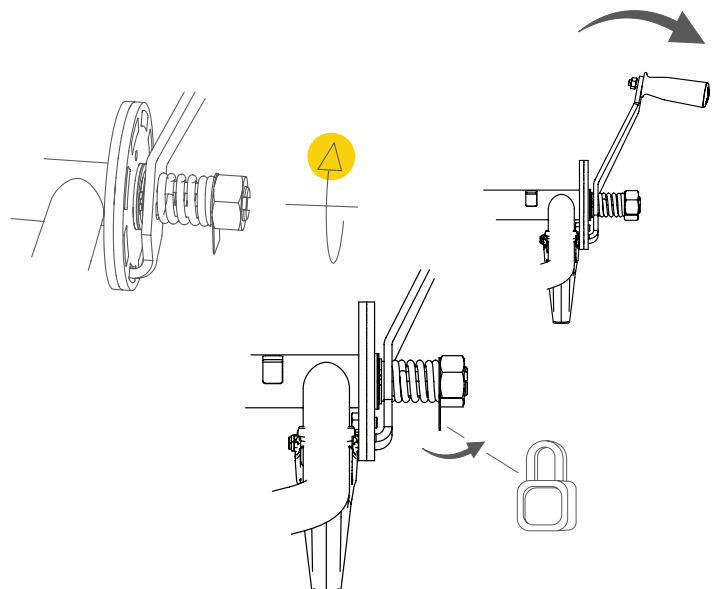

THE FUNCTION OF THE CRANK

The crank that is used for moving the sawhead up and down is spring loaded, and has to be pushed inward to release the locking mechanism while you are raising or lowering the sawhead.

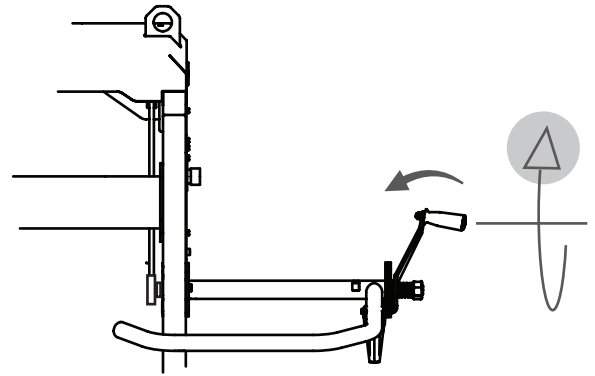
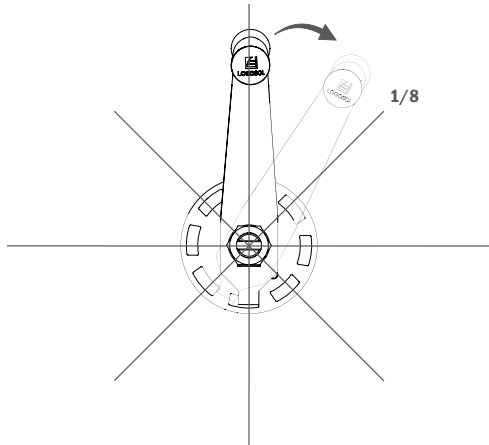

$360^\circ = 1 \text{ inch}$

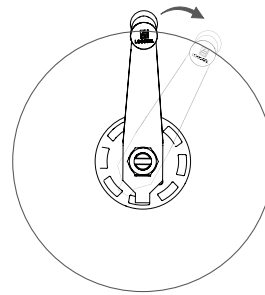

The locking mechanism of the crank is divided in eight steps per revolution. Each step moves the sawhead by 1/8 inch, and one full revolution represents 1 inch. A disc with 16 steps is available as an accessory.

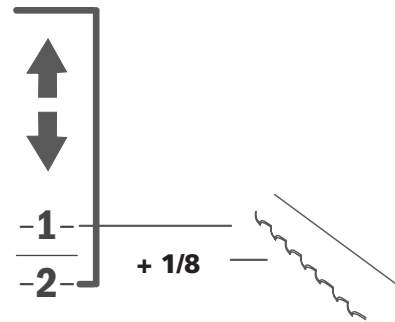
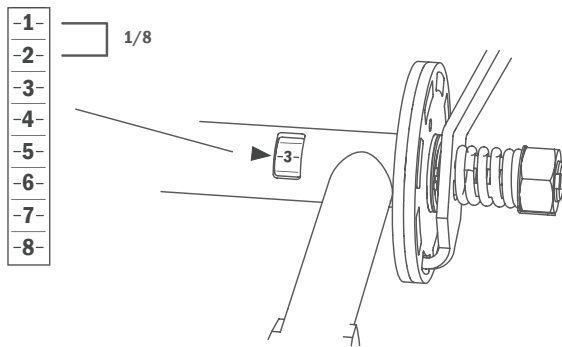

On the crank shaft, there is an opening where you can see numbers on a scale. This scale has eight steps, where each step is 1/8". **TIP:** When a board is cut above the blade, you have to compensate for the kerf, i.e. 1/8". The wood piece below the blade never needs to be kerf compensated. It has the same measurement as the one shown on the absolute scale on the front leg of the carriage.

This is how you use the crank scale when adjusting depth of cut

Example 1: If you are going to cut a 1" board and the crank scale shows the number "3", you first turn the crank one full revolution and stop at "3", then you turn the crank one step (1/8") to number "4".

Example 2: To cut a 2" board starting from "3" on the scale, turn the crank two revolutions and stop at "2".

Example 3: To cut a 3/4" board starting from "3" on the scale, lower 6/8 + one step to compensate for the kerf and stop at "2".



Arkivvägen 6, SE-871 53 Härnösand, Sweden
+46 611-182 85 | info@logosol.com | www.logosol.com