

USER MANUAL

ORIGINAL USER MANUAL

0458-395-5601

REV: 3

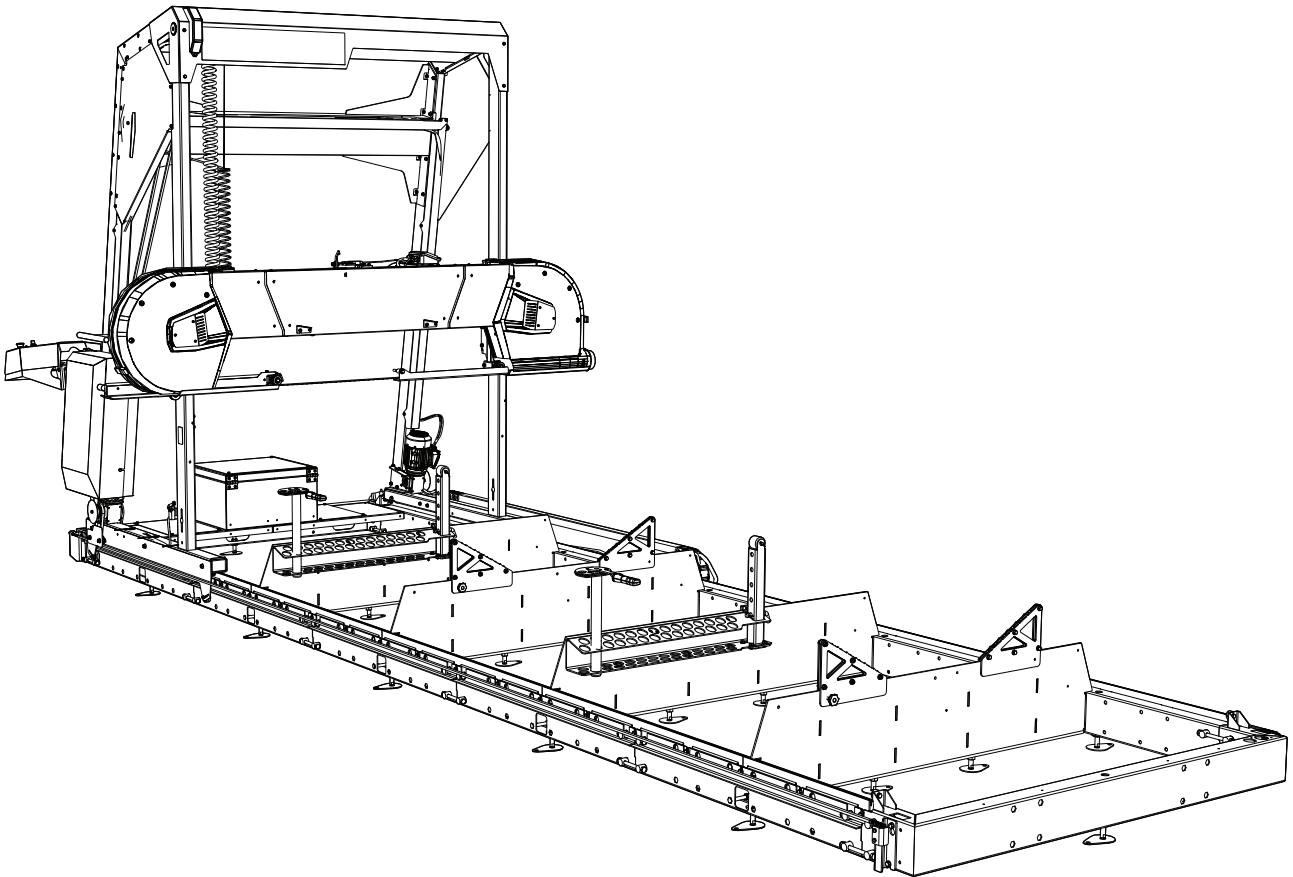

LOGOSOL B1651 BAND SAWMILL



Read through the user manual carefully and make sure you understand its contents before using the saw.



This user manual contains important safety instructions.



WARNING! Incorrect use can result in serious or fatal injuries to the operator or others.

THANK YOU FOR CHOOSING A LOGOSOL MACHINE!

We are very pleased that you have demonstrated your confidence in us by purchasing this sawmill, and we will do our utmost to meet your expectations.

LOGOSOL has been manufacturing sawmills since 1989, and in that time we have supplied approximately 50,000 machines to satisfied customers the world over.

We are concerned with your safety and ensuring that you achieve the best possible results with your sawmill. We therefore recommend that you take the time to read this user manual carefully before starting your sawing. Remember that the machine itself is only a part of the value of the product. Much of the value is also to be found in the expertise we pass on to you in the user manual. It would be a pity if that was not utilised.

We hope you will be thoroughly satisfied with your new machine.

A handwritten signature in black ink that reads 'Bengt-Olov Byström'.

Bengt-Olov Byström
Founder,
Logosol in Härnösand



LOGOSOL continuously develops its products.
For this reason, we must reserve the right to modify the
configuration and design of our products.
Document: B1651 Band Sawmill User Manual
SKU User Manual, English: 0458-395-5601
© 2026 LOGOSOL, Härnösand Sweden

TABLE OF CONTENTS

General information	4
Description of the band sawmill	4
Safety instructions	6
Technical data	8
Bolts/Nuts	9
Component parts	10
Rail assembly	15
Mounting of the rail pipes and support feet	16
Mounting of the platform & toolbox	21
Mounting of the operator panel	22
Mounting of the rail and guidebar	26
Mounting of the cable rail	28
Mounting of the log tension profile	33
Adjusting the rail	36
Mounting of the saw head on the carriage	37
Mounting of the saw head on the rail	44
Mounting of the chain	49
Mounting of the feeding cable	51
Installation of the petrol motor: see separate user manual	54
Order of adjustments	55
Other settings	62
First start-up	65
Starting and stopping	66
Sawmill features	67
Usage	68
Chip collection	70
Operating instructions	71
Maintenance	76
Troubleshooting schedule	80
Declaration of Conformity	84

GENERAL INFORMATION

This user manual, the instruction manual for the motor, the band sawmill's assembly instructions, and the instructions for accessories, are to be regarded as constituent parts of the band sawmill. They must also remain with the band sawmill if it is sold on.

Responsibility for correct assembly, commissioning and use of the band sawmill rests with whoever has assembled it and the people who use it.

Disclaimer: The actual appearance of the system and its components may vary slightly from the illustrations shown. These variations do not affect the functionality or performance of the machine.

DESCRIPTION OF THE BAND SAWMILL

B1651

Front view

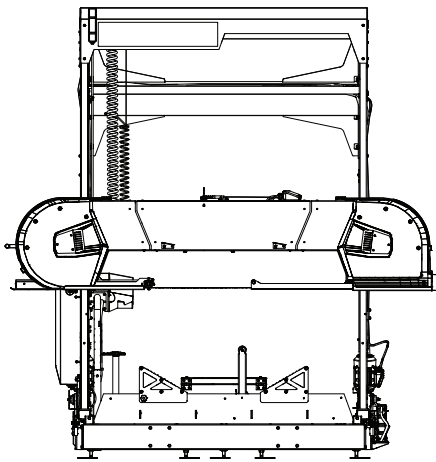

Rear view

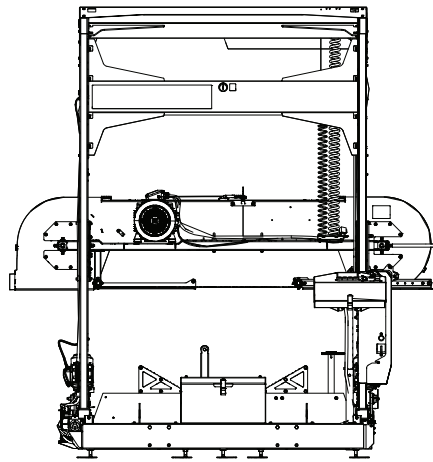

Side view

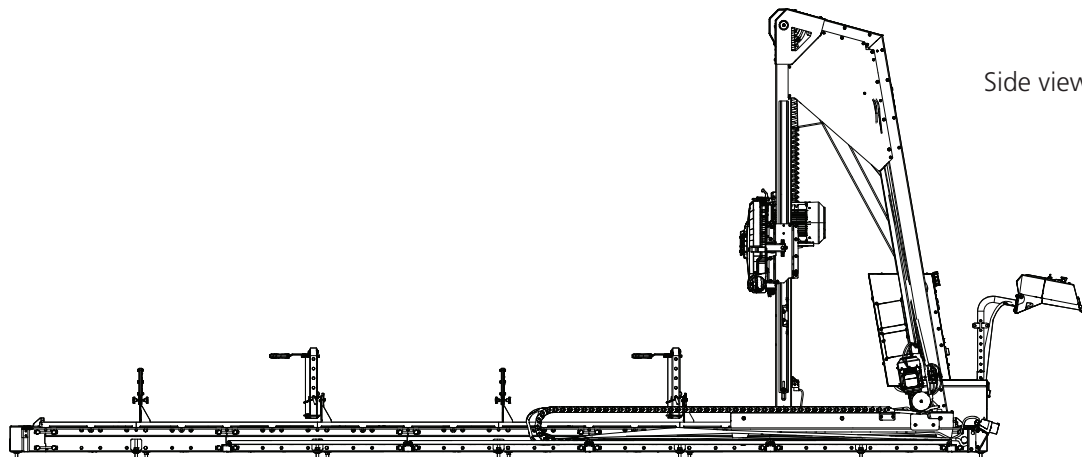

DESCRIPTION OF THE BAND SAWMILL

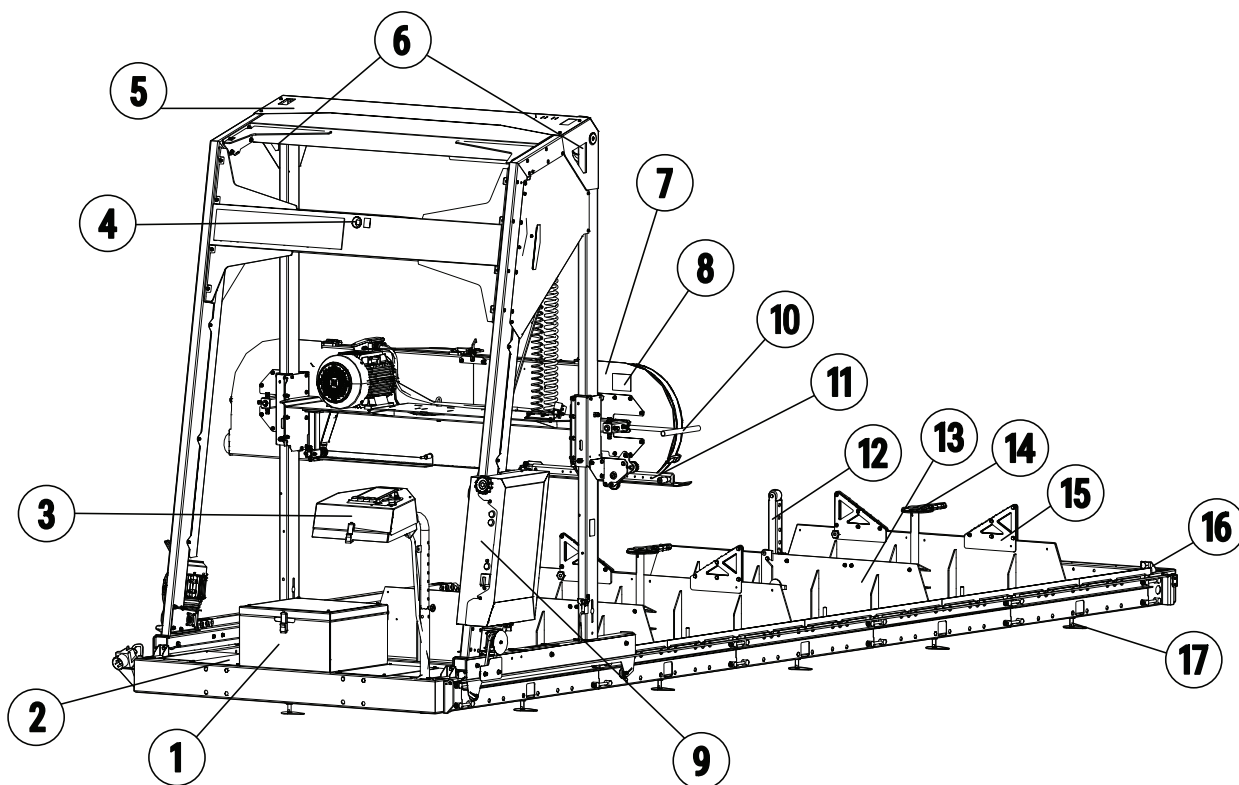

1. Toolbox
2. Platform
3. Operator panel
4. Water tank
5. Saw carriage
6. Lifting points
7. Band wheel guard
8. Machine decal
9. Electrical cabinet
10. Blade tension handle
11. Adjustable blade guard
12. Log support
13. Cross bunk
14. Log clamp
15. Log wedge
16. Rail end stop
17. Leveling foot

SAFETY INSTRUCTIONS

KEY TO SYMBOLS



WARNING! This symbol means that you have to take particular care. It is always accompanied by information on the specific risk.



ATTENTION. A warning comes after this symbol. Pay particular attention where this symbol appears in the manual text.



For your own safety and that of others, do not use the bandsaw mill or handle bandsaw blades without first reading through and understanding the contents of this user manual in its entirety.



WARNING! Cutting tools: Incorrect use of the machine can lead to life-threatening injuries. Bandsaw blades are extremely sharp and dangerous.



Always wear protective gloves (class 1) when fitting and working with the band sawmill or handling bandsaw blades. Risk of lacerations when handling bandsaw blades and some sheet metal. Bandsaw blades and motor parts can be hot after sawing.



Always use approved hearing protection when working with the machine. Even brief exposure to high frequency noise can damage your hearing. Always use close-fitting safety goggles when working with the machine or handling bandsaw blades. Under certain circumstances the use of a protective mask may also be advisable. This would primarily apply if you are sawing dry wood or sawing indoors.



Always wear approved protective footwear with saw protection, steel toe-caps and non-slip soles when working with the machine or handling bandsaw blades.



Always wear full-length protective trousers when working with the machine or handling band blades. Never wear loose-fitting clothing, scarves, neck chains, etc. that can get caught in the machine when working. Secure loose hair before working with the Band sawmill.



This symbol shows that there is a helpful tip nearby!

SAFETY INSTRUCTIONS

THE BAND SAWMILL'S SAFETY EQUIPMENT

 **WARNING!** Never use the machine if the safety equipment is defective..

 Safety equipment must be checked and maintained.

Here is a description of the items of safety equipment on the band sawmill, together with their features.

Interlocking the band wheel guards

One of the hinges on the band wheel guards is fitted with safety switches. The hatches must be closed before using the machine.

Rail end stops

These mechanical stops prevent the saw carriage rolling off the end of the rail.

OPERATOR

 **WARNING!** Whenever the machine is used, approved personal protective equipment must always be used.

 Persons under the age of 18 may not use the band sawmill or handle bandsaw blades.

 Never use the machine or handle bandsaw blades if you are tired, if you have consumed alcohol or are taking medicine that can impair your sight, judgment or control over your body.

WORK SITE

 **WARNING!** Never operate a band sawmill with a combustion engine in an enclosed or poorly ventilated area. Doing so can cause death by asphyxiation or carbon monoxide poisoning.

 The use of the band sawmill and the handling of saw blades must be carried out in broad daylight or in adequate work lighting.

 Keep the workplace free of debris, pets, children, obstacles and anything else that may distract the operator.

 Choose an work site where the supporting ground is tightly compacted and level, with generous space for the band sawmill, log piles and sawn wood. If possible, position the band sawmill so that the sawdust is blown away from the operator station. Set up the band sawmill on a level surface, with at least 5 m of clear, obstacle-free space all around the machine. If the band sawmill is to be set up permanently, we recommend supporting the bandsaw rail on cement slabs or wooden blocks (15 cm x 15 cm) placed under each crossbar.

 Always have an ABC type handheld fire extinguisher (min. 6 kg) readily available at the work site.

 Always have a complete first aid kit to hand at the work site.

TECHNICAL DATA

LOGOSOL B1651	
RAIL COMPONENT	
Rail length, standard	6232 mm
Rail length, extension	1156 mm
Track width	1,75 m
Overall width	1,92 m
Height	240 mm
Weight (6.23 m rail)	500 kg
SAW CARRIAGE	
Length	1,42 m
Width	2715 mm
Height	2850 mm +- 40 mm (support legs)
Weight	350 kg
Volume, water reservoir	25 liters
Feed rate	Variable
CAPACITY	
Max. log diameter	1651 mm
Max. sawing width	1500 mm
Effective saw length (standard)	4380 mm
BANDSAW BLADE	
Type and size	5610x33 pitch 22 mm
Band wheel diameter	500 mm
Band wheel, rotational speed	1000 v/min
Saw blade, speed	30 m/s
SAW MOTOR(S)/ENGINE	
Electric motor drive	12 kW, 400 V (Weight: 65 kg)
Fuse	25 A
Petrol engine	Loncin 27 hp
Volume, fuel tank	5 litres
NOISE LEVEL/VIBRATIONS	
Equivalent sound pressure level at ear of operator 1)	88.4 dB(A)
Sound power level (estimated) 2)	109.4 dB(A)
Vibration level in handle 3)	<2.5 m/s ²

1) The typical distribution measurement for equivalent sound pressure level is a standard deviation of 2 dB(A)

2) The typical distribution measurement for sound power level is a standard deviation of 3 dB(A)

3) The typical distribution measurement for vibration level in the handles is 1 m/s²

BOLTS/NUTS

Definition of the fasteners on following pages.

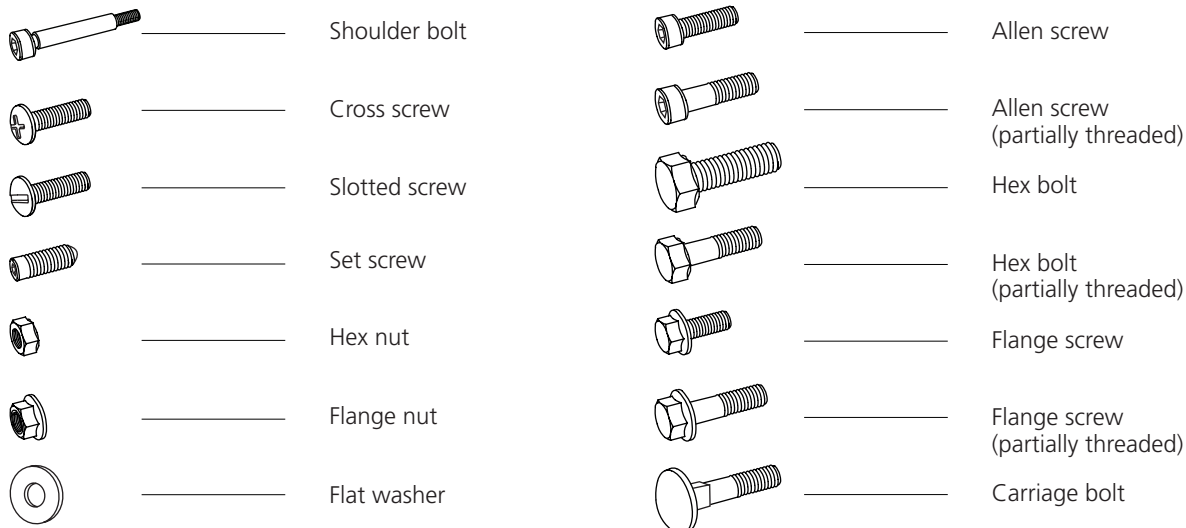

ADDITIONAL SYMBOLS

The following symbols are used in addition to those shown above to describe part design.



DIMENSIONS/LENGTH

The dimensions of the fasteners are printed as a diameter dimension (M) ISO 68-1. This is followed by a length dimensions for bolts/screws; the dimension of a bolt/screw is the part of the bolt/screw that disappears into the material in which it is mounted.

(Diameter) **(Length)**
 M8 x 20

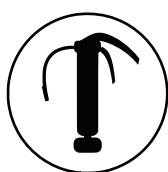

When this symbol appears during assembly, parts must be lubricated before installation. Lubricate affected parts with universal grease.



This symbol describes the recommended lifting point for heavy lifts.

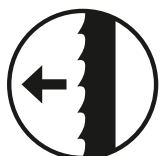

This symbol describes the sawing direction and reappears during assembly.



Make the joint finger-tight.



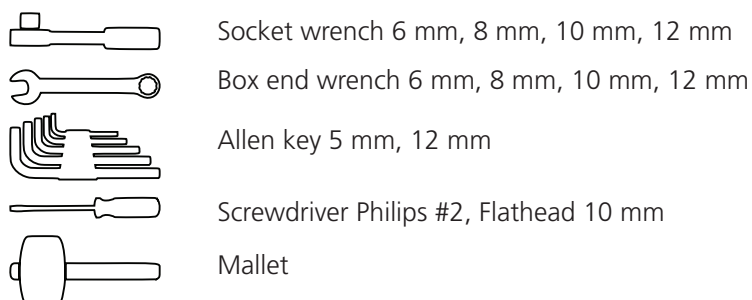







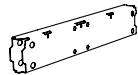



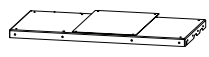
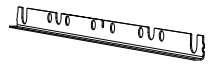

Recommended Tools

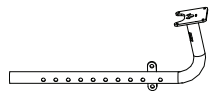
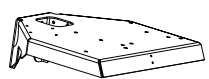

COMPONENT PARTS

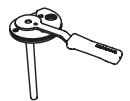

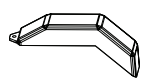
01-00931 SB-1

-  — 10 x — 03-01971
-  — 14 x — 03-01973
-  — 4 x — 03-02180
-  — 4 x — 03-01972
-  — 2 x — 03-02642
-  — 2 x — 03-03686
-  — 2 x — 01-00957
-  — 10 x — 03-02459
-  — 1 x — 02-00564
-  — 1 x — 02-00449
-  — 1 x — 02-00465
-  — 4 x — 03-03747
-  — 2 x — 03-03748
-  — 4 x — 01-00935
-  — 2 x — 01-00453
-  — 2 x — 01-00938
-  — 1 x — 02-00247
-  — 1 x — 03-03706
-  — 1 x — 01-00959



— 1 x — 03-03054



— 1 x — 04-00752

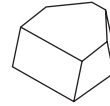

— 1 x — 03-03756



01-00334-DM (2 x)

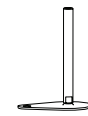

— 10 x — 9039-001-0001



— 20 x — M16



— 12 x — 03-03786



01-00335-DM (2 x)

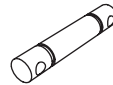

— 24 x — 03-01814

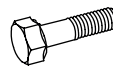

— 24 x — M12x140



— 24 x — M12



01-00955-SKP

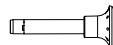

— 1 x — 04-00521



— 6 x — M6X16



— 4 x — M6



01-00961-PAR



— 2 x — 03-01465



— 2 x — 03-01464



— 2 x — 9291-020-0005
(8.5x12x11mm)



— 2 x — 03-03681



— 2 x — M8x20



— 2 x — M8x25



— 2 x — M8



01-00956-SKP

- 4 x — M5x20
- 16 x — M6x10
- 4 x — M6x20
- 5 x — M6x70
- 2 x — M8x100
- 2 x — M8x16
- 4 x — M5
- 25 x — M6
- 4 x — M8



01-00958-DIV

- 4 x — 01-00421
- 1 x — 03-02972
- 1 x — 03-03763
- 1 x — 03-02668
- 1 x — 03-03764
- 4 x — 04-00443 (6.3x10x10mm)
- 2 x — 03-02963
- 2 x — 9023-013-0002



01-00937-DIV

- 2 x — 03-02650
- 2 x — 03-02461
- 2 x — 9321-633-0112



01-00960-SKP

- 42 x — M8x16
- 42 x — M8



01-00959-DIV

- 1 x — 03-03708
- 1 x — M10x80
- 1 x — M6x16
- 1 x — M6
- 1 x — M6



01-00937-SKP

- 2 x — 9321-635-3225
- 2 x — 9321-636-1260
- 8 x — M8x20
- 6 x — M8x14
- 14 x — M8



01-00958-SKP

- 8 x — M8x20
- 4 x — M6x30
- 8 x — M8
- 8 x — M6







COMPONENT PARTS

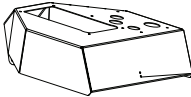
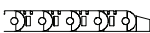
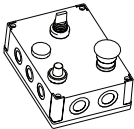
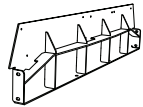

01-00931-BE2

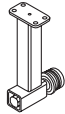
This package is delivered if you have a petrol engine.

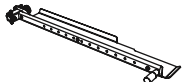

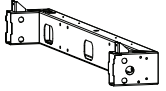
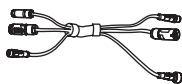
	— 1 x —	01-00939
	— 1 x —	01-00953
	— 1 x —	04-00734
	— 1 x —	01-00947
	— 4 x —	02-00554
	— 2 x —	03-03730
	— 1 x —	01-00269
	— 2 x —	03-03899
	— 1 x —	01-00321
	— 1 x —	01-00330
	— 1 x —	9007-133-5610
	— 2 x —	02-00556
	— 1 x —	01-01049

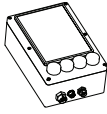





	— 1 x —	$\frac{\text{mm}}$ 01-00916
		— or —
	— 1 x —	$\frac{\text{inch}}$ 01-01119

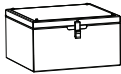
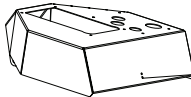
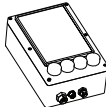
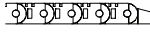
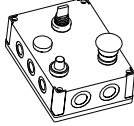
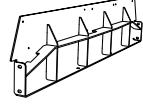

01-00931-EL2

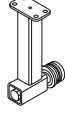

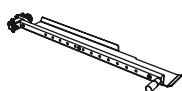
This package is delivered if you have an electric motor.

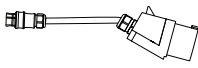
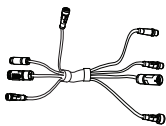
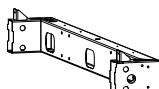

	— 1 x —	01-00939
	— 1 x —	01-00953
	— 1 x —	01-00899
	— 1 x —	04-00734
	— 1 x —	01-00947
	— 4 x —	02-00554
	— 2 x —	03-03730
	— 1 x —	01-00269
	— 2 x —	03-03899
	— 1 x —	01-00321
	— 1 x —	01-00330
	— 1 x —	9007-133-5610
	— 1 x —	02-00571
	— 1 x —	01-01033 (6 m)
	— 1 x —	01-00945 (10 m)
	— 2 x —	02-00556





01-00956-DIV

-  — 5 x — 03-03705
-  — 5 x — 03-03704
-  — 1 x — 03-03703











01-00330-DIV

-  — 1 x — 9038-012-0001 (0,9 m)
-  — 1 x — M8x25
-  — 1 x — 4900-003-0225

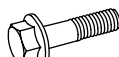



01-00977-DIV

-  — 4 x — 9029-011-0001
-  — 4 x — 9026-015-0002
-  — 4 x — M6x35
-  — 4 x — M8x12
-  — 2 x — M10x95
-  — 4 x — M6
-  — 2 x — M10
-  — 4 x — 03-01982



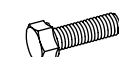





02-00554-SKP

-  — 16 x — M12x90
-  — 16 x — M12
-  — 16 x — M12

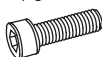





01-00953-DIV

-  — 1 x — 9036-011-0001
-  — 2 x — M6x10
-  — 2 x — M6
-  — 4 x — M4x20
-  — 4 x — M4
-  — 4 x — M4x8
-  — 4 x — M5x20







01-00747-SKP

-  — 4 x — M8x12
-  — 2 x — M8x20
-  — 1 x — M8x60
-  — 3 x — M8







01-01006

-  — 1 x — 04-00063
-  — 2 x — M10
-  — 1 x — M10x40
-  — 1 x — M10







01-00269-DIV

-  — 1 x — 03-01771 (2 mm)
-  — 1 x — 03-01772 (1 mm)
-  — 1 x — 03-01773 (0.5 mm)
-  — 4 x — M8x16



01-00957-SKP

-  — 14 x — M6x12
-  — 10 x — M6
-  — 6 x — M12
-  — 6 x — M12x90



01-00942-DIV



01-01039

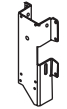

— 1 x ——— 02-00498



— 2 x ——— 03-03787



— 2 x ——— M12x32 (GN 913.3 P)



— 1 x ——— M12x40 (GN 913.3 P)



— 3 x ——— M12



— 7 x ——— M8x20



— 2 x ——— M8x12



— 1 x ——— M8x12



— 7 x ——— M8



01-01040

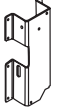

— 1 x ——— 02-00561



— 2 x ——— 03-03787



— 2 x ——— M12x32 (GN 913.3 P)



— 2 x ——— M12



— 7 x ——— M8x20



— 2 x ——— M8x12



— 2 x ——— M8x12



— 7 x ——— M8



1 x ——— 01-00942

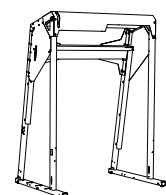

— 1 x ——— 01-00932



RAIL ASSEMBLY

Start assembling the sawmill by mounting the rail. The rail sections are placed under the saw head in the pallet. The assembly involves heavy lifting and requires two people.



WARNING! Heavy lifting! Risk of injury.



WARNING! Risk of crush injuries.



IMPORTANT. Two people are always required to help with heavy lifting.



WEAR PROTECTIVE GLOVES. Always wear protective gloves and handle the motor carefully when placed on the motor shelf.

EXTRA EQUIPMENT

There are accessories for this machine that may affect the sequence of assembly in this manual. Read through the assembly instructions in the various manuals before starting work for an overview of the various procedures.



Follow the steps of assembly carefully and use an ergonomically correct work position while working. Work on level ground, as this will facilitate when adjusting the rails.



Read through all the assembly instructions before starting assembly, then follow the instructions step by step as you work.



MOUNTING OF THE RAIL PIPES AND SUPPORT FEET

When installing trailer kits and accessories that require fixed support legs: skip step 1 (see manual for the product in question).

There are accessories for this machine that may affect the sequence of assembly in this manual. Read through the assembly instructions in the various manuals before starting work to get an overview of the different procedures.

1

The support legs will be fitted to all ten rail pipes.



01-00334-DM

10 x

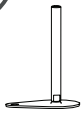

20 x



M16

20 x



03-03786

10 x

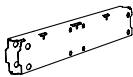

03-01971

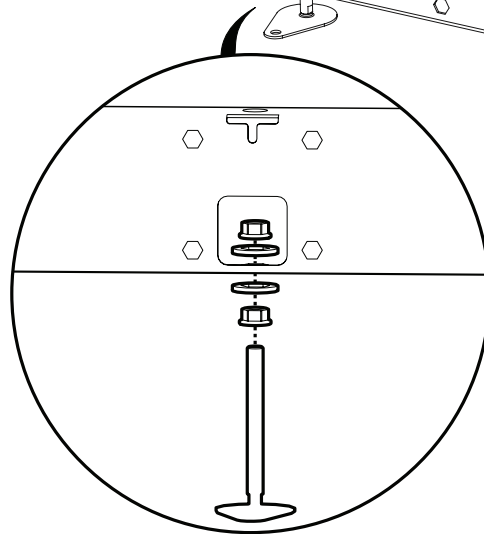
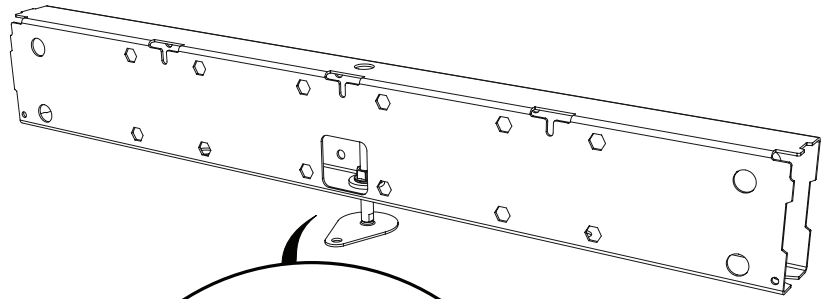

2



01-00335-DM

4 x

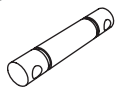

03-01814

2 x

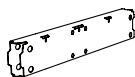

03-01971

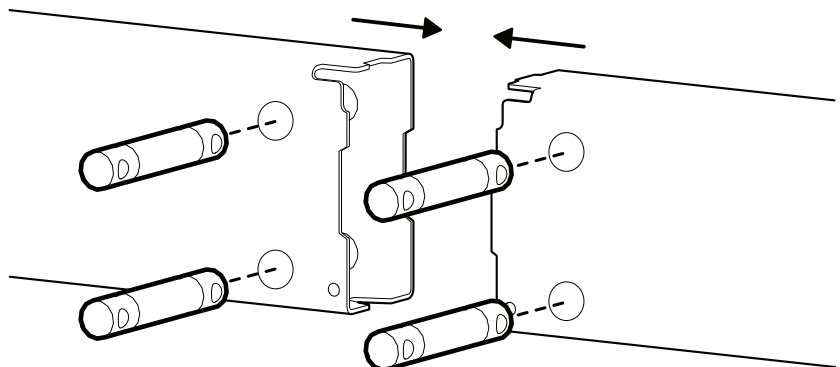



3

Gradually tighten the nuts on both sides to prevent misalignment.

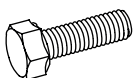

01-00335-DM

- 4 x  M12x140
- 4 x  M12

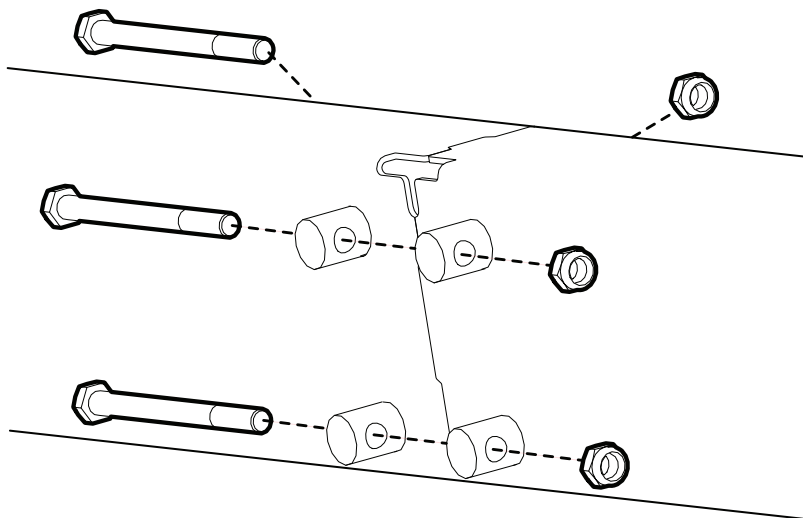

4



01-00335-DM

- 12 x  M12x140
- 12 x  M12
- 12 x  03-01814
- 2 x  03-01971

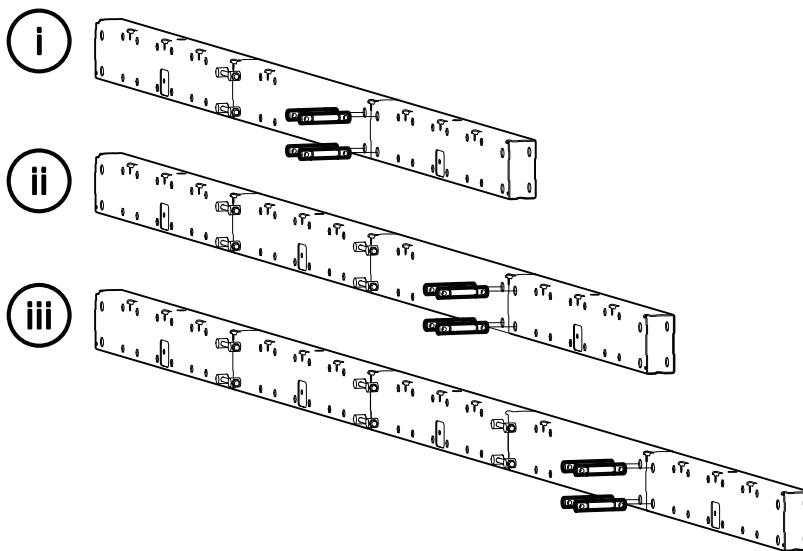

5

Repeat steps 2 to 4 for the second rail pipe.

6



01-00334-DM

8 x

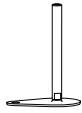

9039-001-0001

16 x



M8

4 x

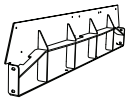

02-00554

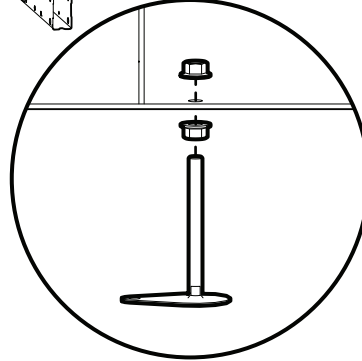
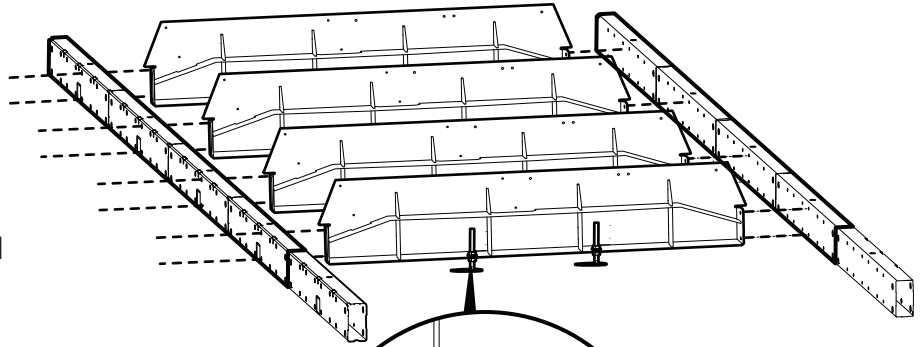

7

Attach the cross bunks to the rail pipes number **2, 3, 4** and **5** seen from the sawing direction. Count the hole patterns from the pipe joint; the cross bunks should be placed on hole pattern **4** from each respective pipe joint. Fasten the bolts fingertight and make sure that the bolt heads are level with the rail pipe.

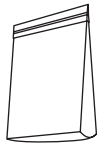

02-00554-SKP

16 x

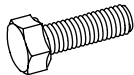

M12x90

16 x



M12

16 x



M12

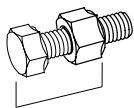

78.5 mm

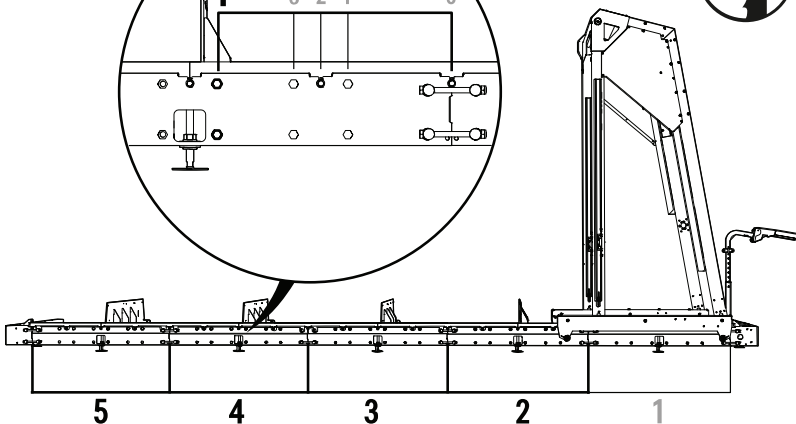
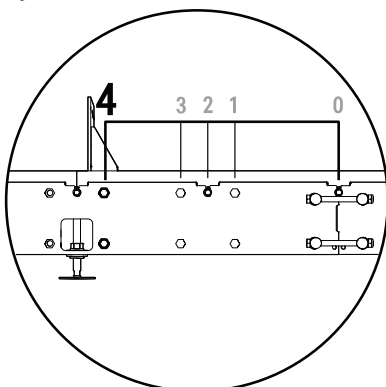
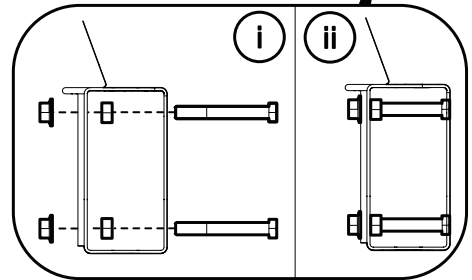
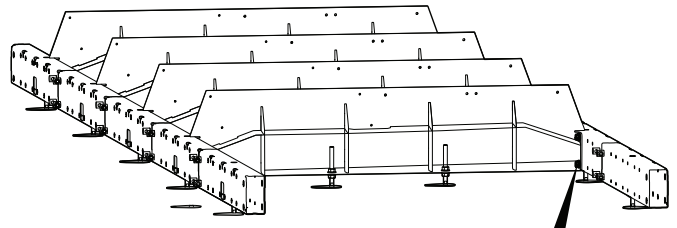

8



01-00334-DM

- 1 x
- 2 x M16
- 2 x 03-03786
- 1 x 02-00556

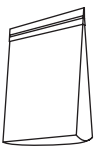
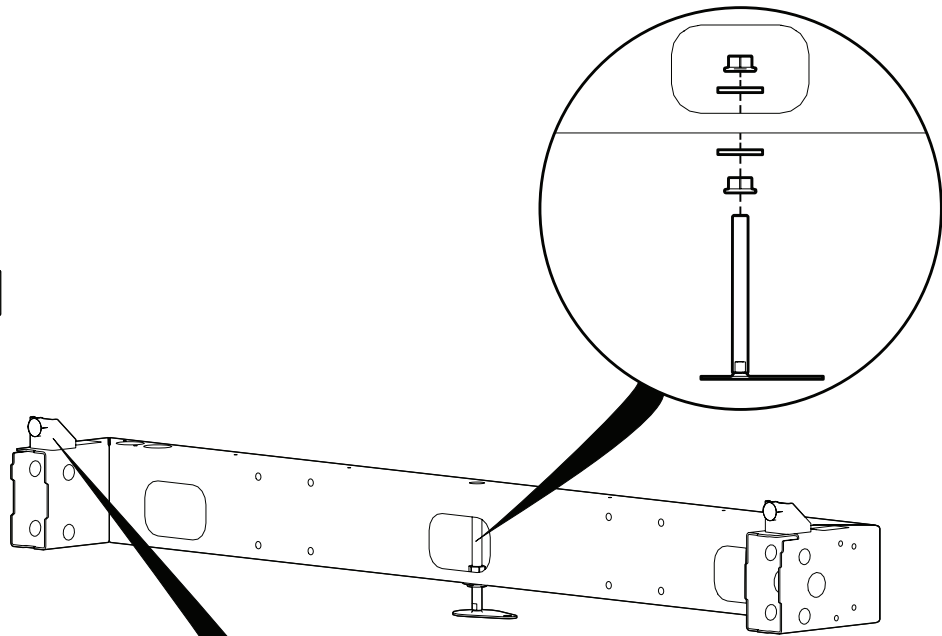

01-00977-DIV

- 2 x M8x12
- 2 x 9026-015-0002

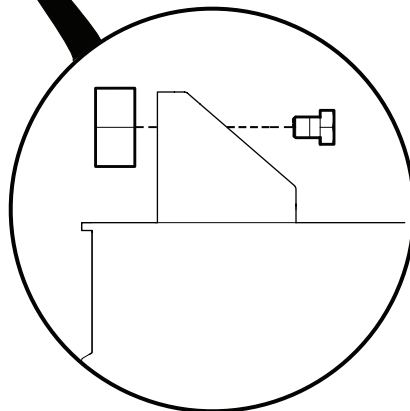

9



01-00335-DM

4 x

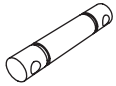

03-01814

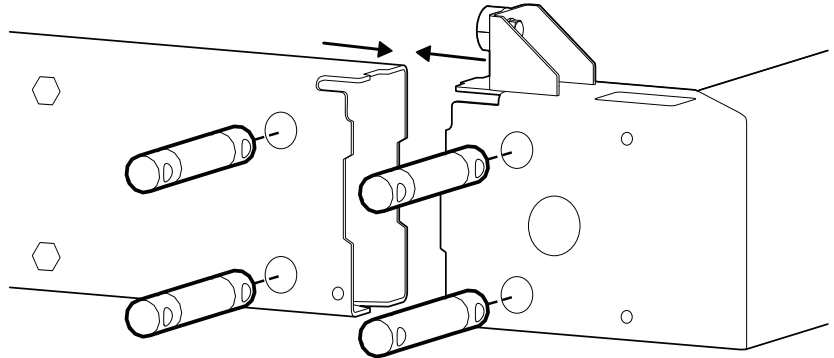

10



01-00335-DM

4 x

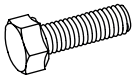

M12x140

4 x



M12

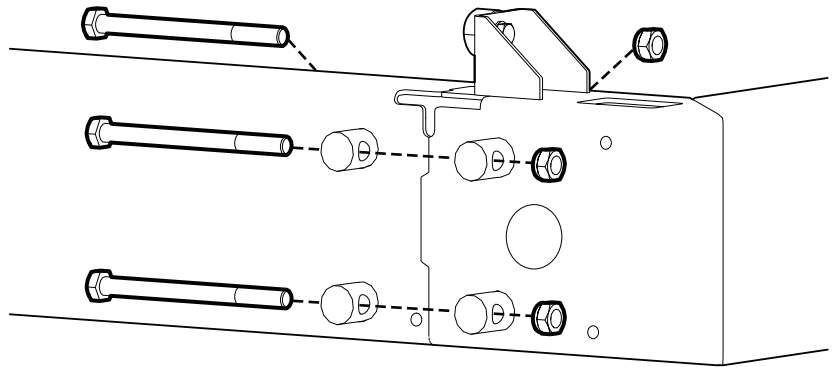

11

Repeat the steps 8, 9 and 10 for the second rail pipe edge piece.

12

Tighten the bolts from step 7.



MOUNTING OF THE PLATFORM & TOOLBOX

1

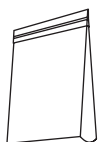

01-00957-SKP

4 x M6x12

4 x M6

2 x 01-00957

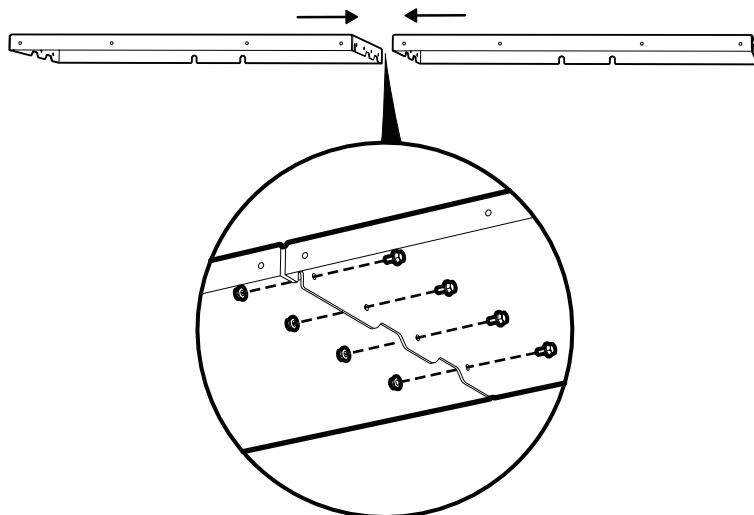
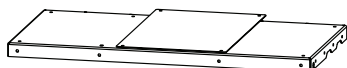

2

Please note the direction of the saw blade before mounting the platform. Lower the platform in place. Attach the bolts to its sides and back. The assembly is symmetrical around the platform.



01-00957-SKP

6 x M12x90

6 x M12

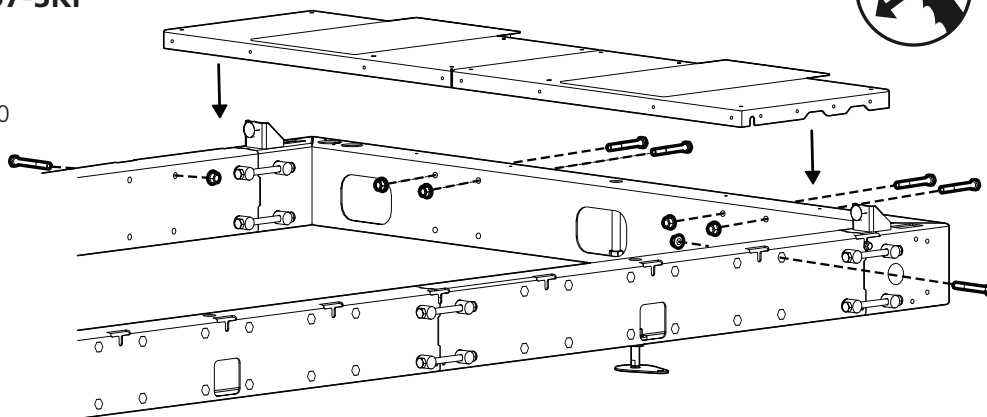

3

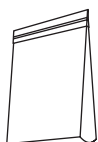

01-00957-SKP

4 x M6x12

4 x M6

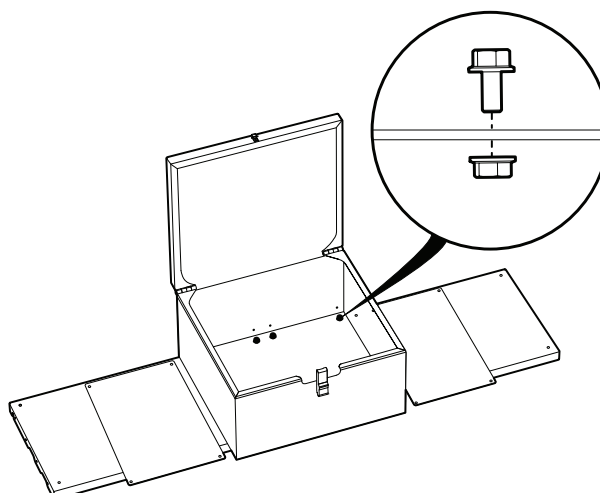



MOUNTING OF THE OPERATOR PANEL

1

Please note the direction of the saw blade before assembling the following steps.

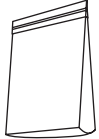

01-00955-SKP

4 x  M8x16

1 x  02-00564

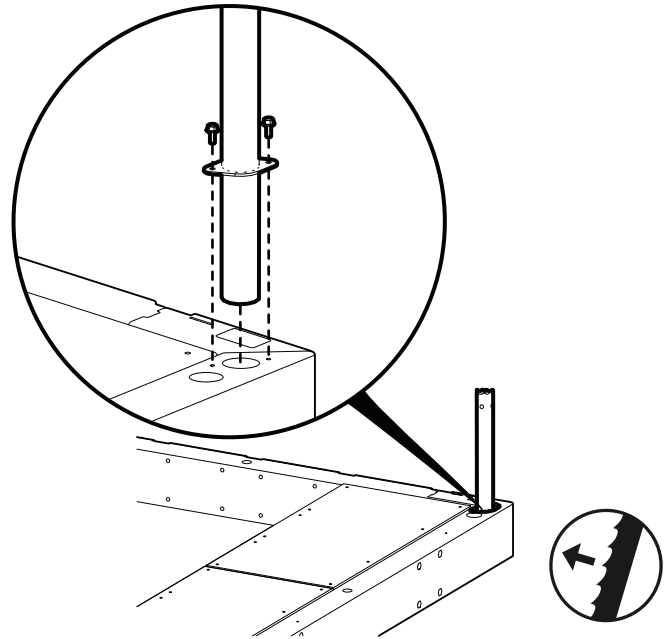

2

Use the holes in the tube to position the operator panel at your desired height. It is recommended to have it set just above your stomach. Using the holes above the seam allows free rotational movement of the operator panel. Using the hole under the seam locks the operator panel in position, which can be useful while transporting the band saw.

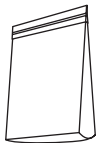

01-00955-SKP

1 x  04-00521

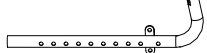
1 x  02-00449

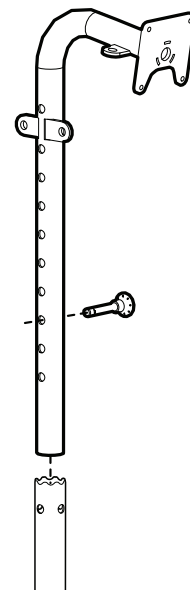

3

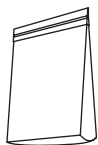

01-00955-SKP
+
01-00953-DIV

4 x  M6x16

6 x  M6

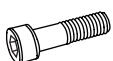
2 x  M6x10

1 x  02-00465

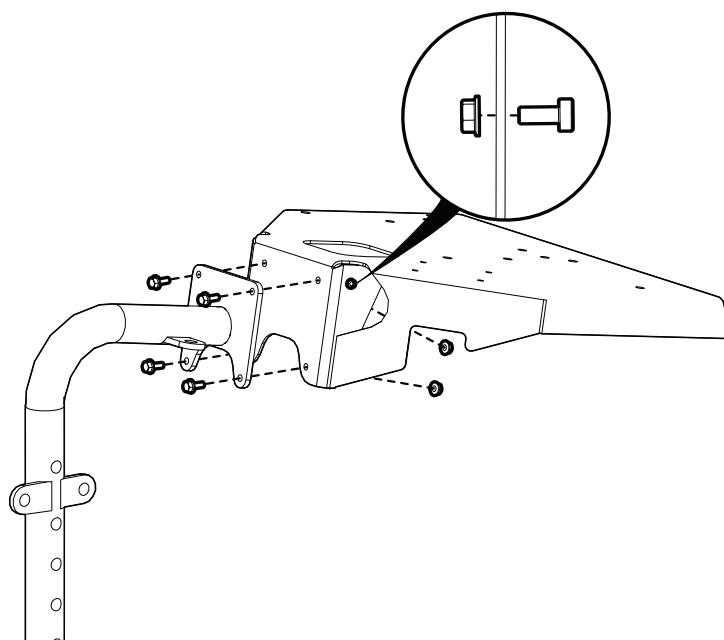

4

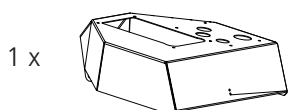

03-03699

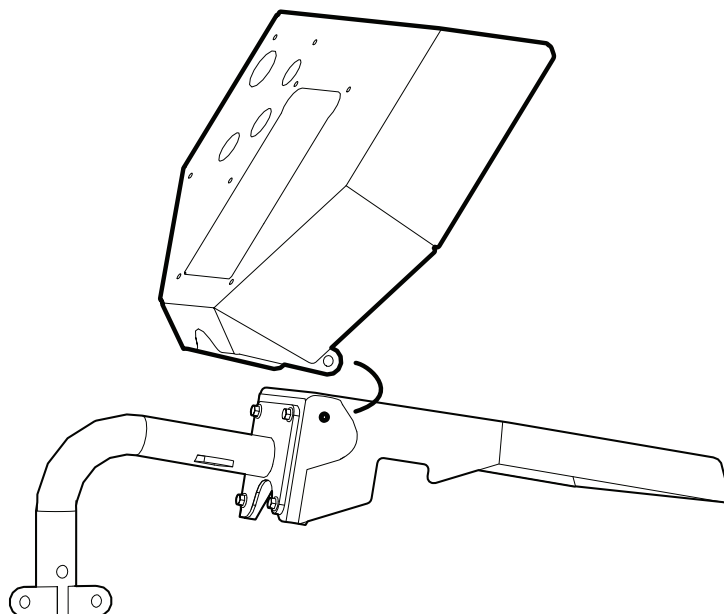

5

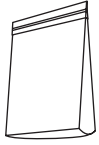

01-00953-DIV

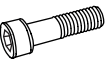
2 x  M4x8

2 x  M4

1 x  9036-011-0001

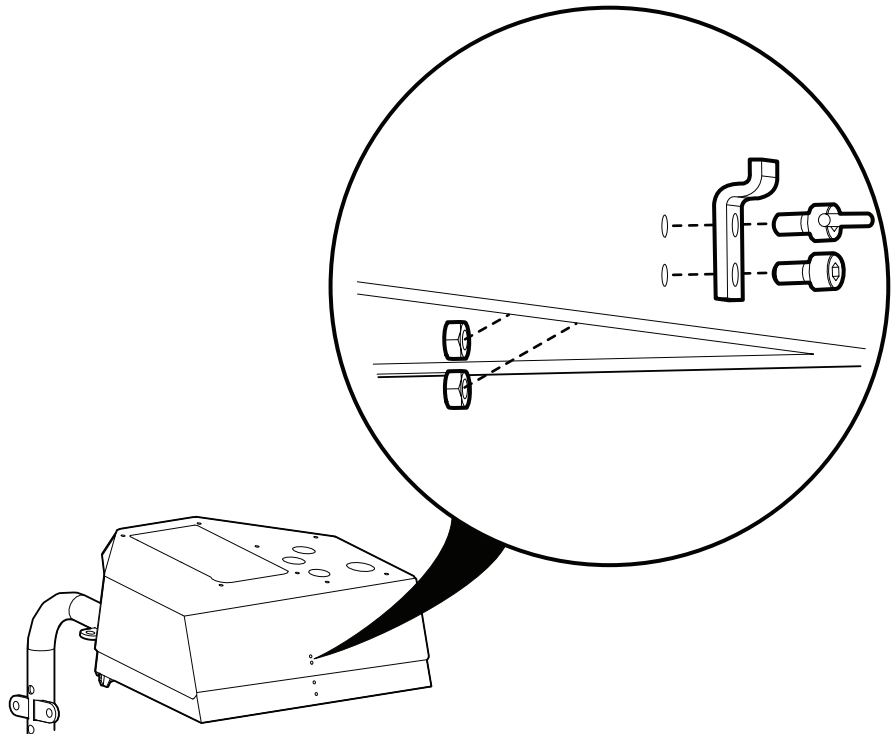

6

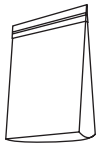

01-00953-DIV

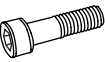
2 x  M4x8

2 x  M4

1 x  9036-011-0001

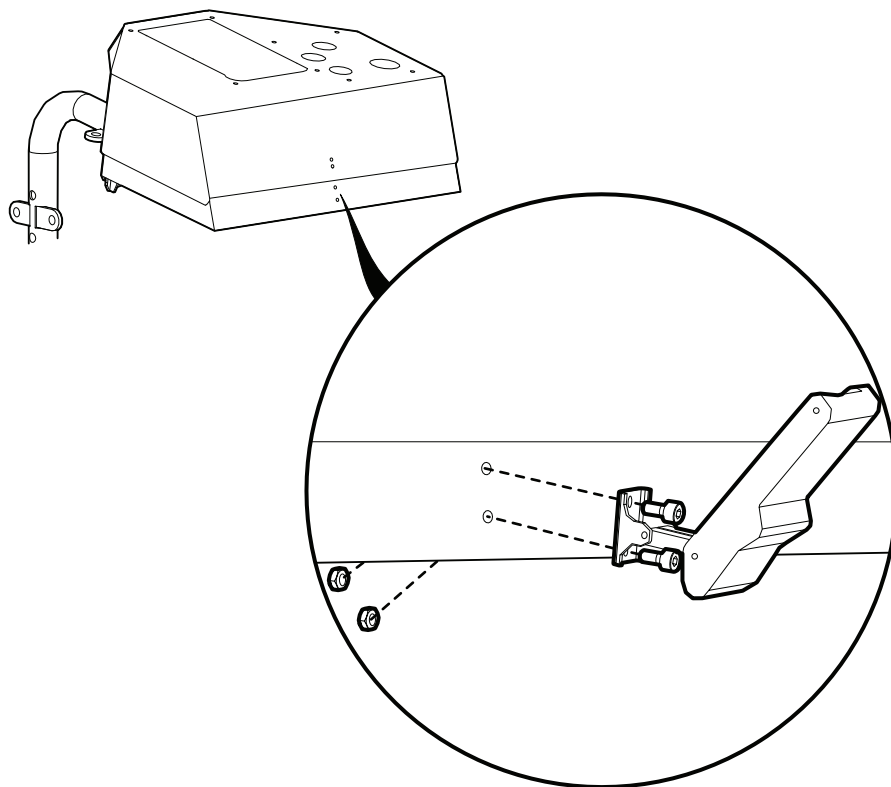

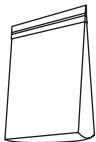

7

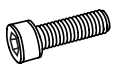

01-00953-DIV

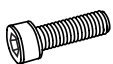
4 x  M5x20

4 x  M4x20

1 x  01-00947

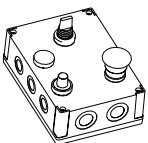
1 x  01-00899

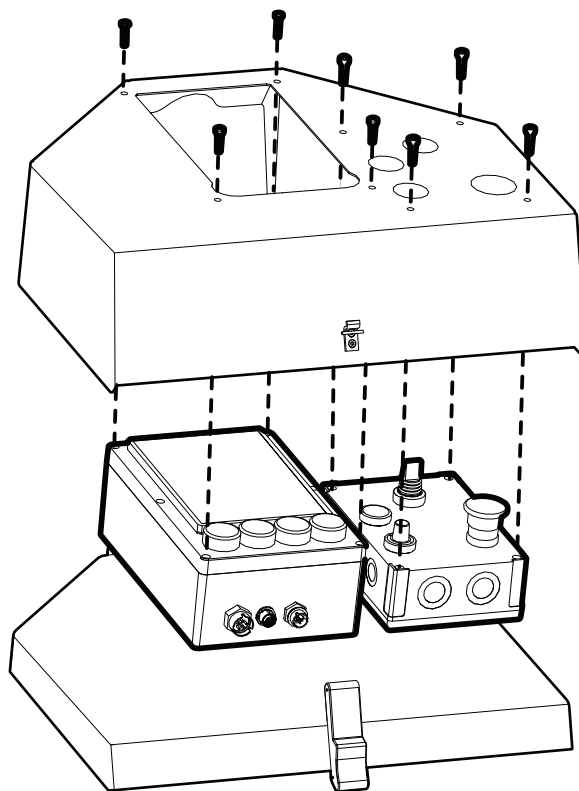



MOUNTING OF THE RAIL AND GUIDE BAR

1

Leave a distance between the bolt head and the nut. This distance should be 8-10 mm.

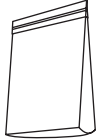

01-00960-SKP

1 x M8x16

1 x M8

i

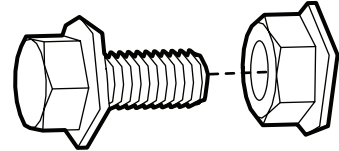

ii

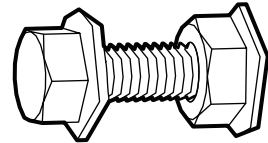

2

The rail sections should be fitted so that they overlap each other. The last short rail section should be fitted the same way as the first one.

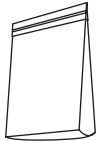

01-00960-SKP

21 x M8x16

21 x M8

1 x 03-01972 (602 mm)

1 x 03-02180 (1195 mm)

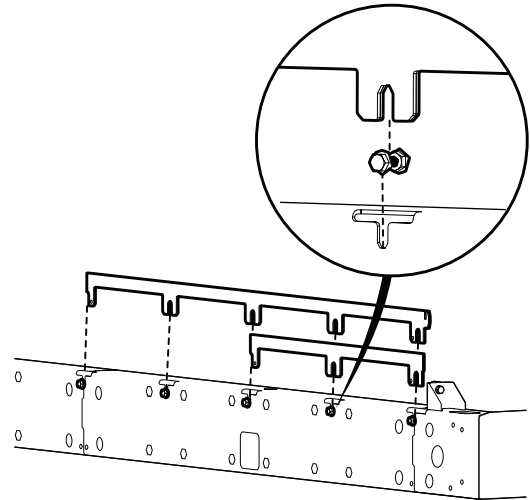

3

1 x 03-01972 (602 mm)

1 x 03-02180 (1195 mm)

7 x 03-01973 (1156 mm)

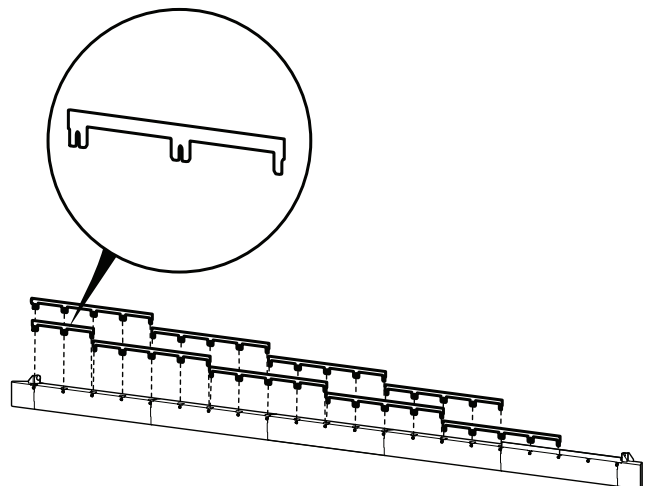

4

After the rails have been positioned, slide the guide bars in place along the rail pipe and tighten the bolt with your fingers. Make sure the guidebar is pushed all the way up and aligned at the bottom.

5 x

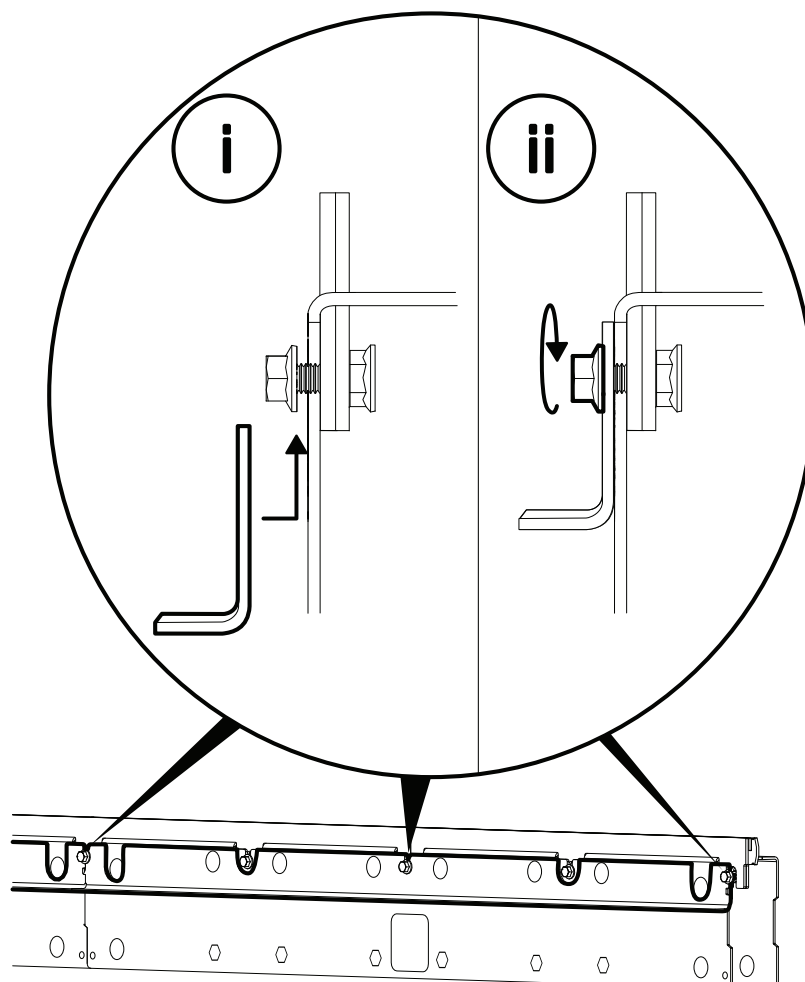

03-02459

**5**

Repeat the installation on the other side. See step 1-4 above.



MOUNTING OF THE CABLE RAIL

1

Please note the direction of the saw blade before assembling the following steps.

5 x  03-03704

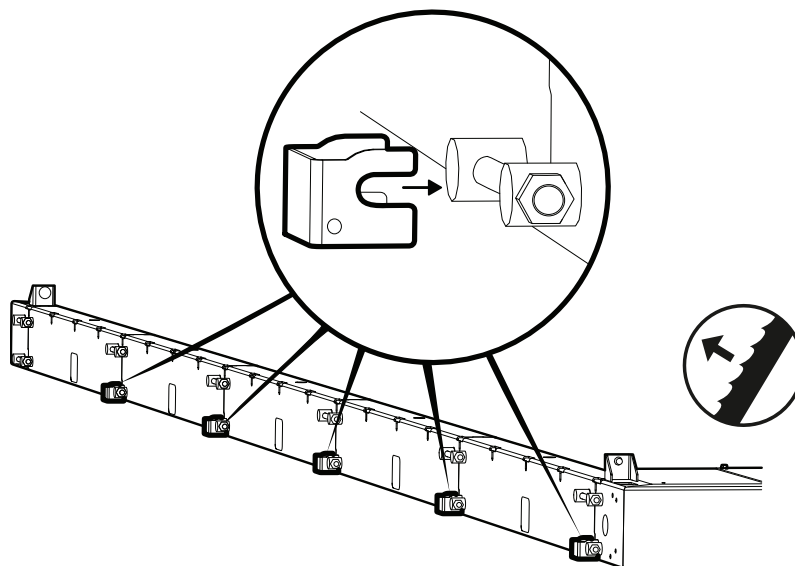

2

5 x  03-03705

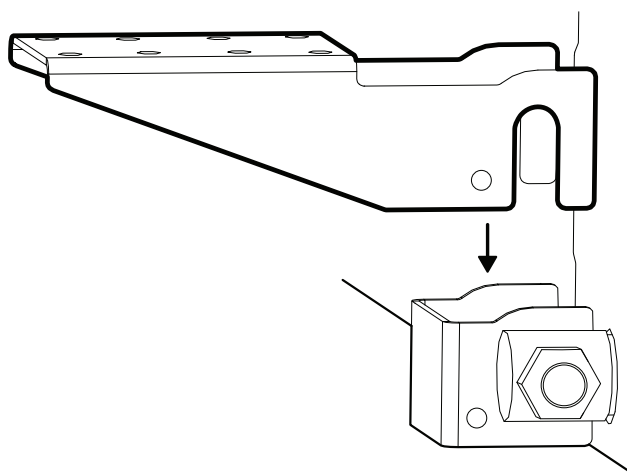

3

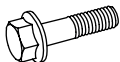

 01-00956-SKP

5 x  M6x70

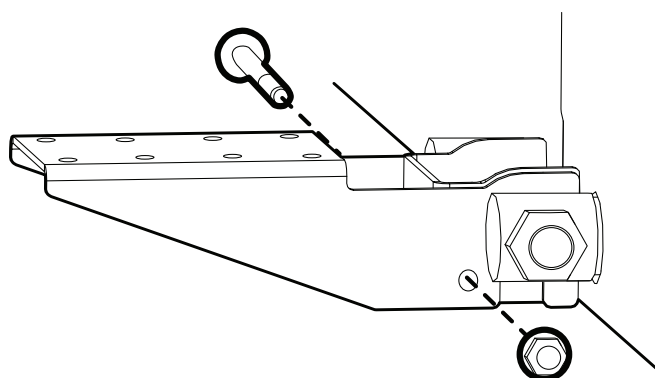
5 x  M6



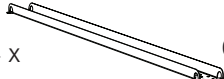

4

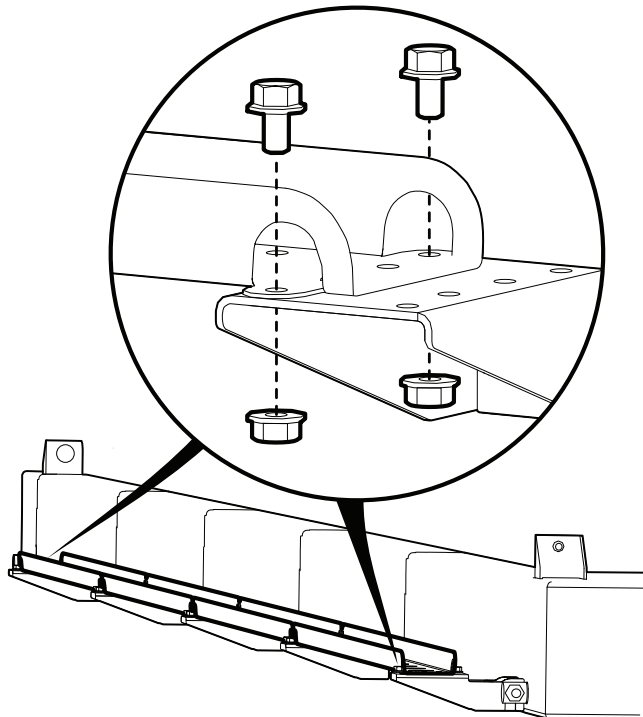
- 4 x  M6x10
- 4 x  M6
- 4 x  03-03747



5

- 12 x  M6x10
- 12 x  M6

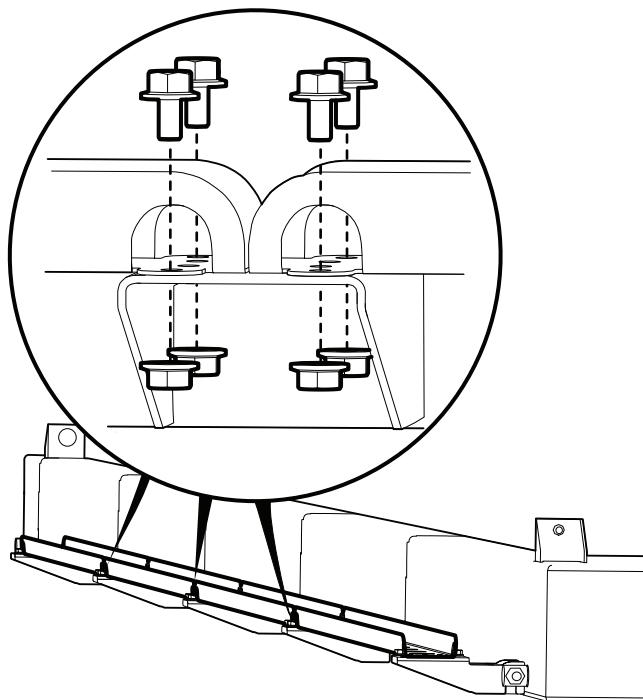

6

2 x  M6x20

2 x  M6

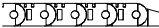
1 x  04-00734

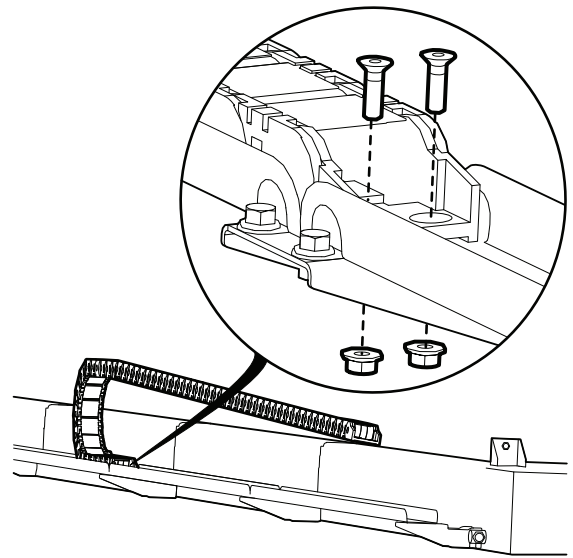

7

Lay the cable holder out flat and open the lids with a flathead screwdriver. Stick the screwdriver against the wall above the latch and bend downwards.

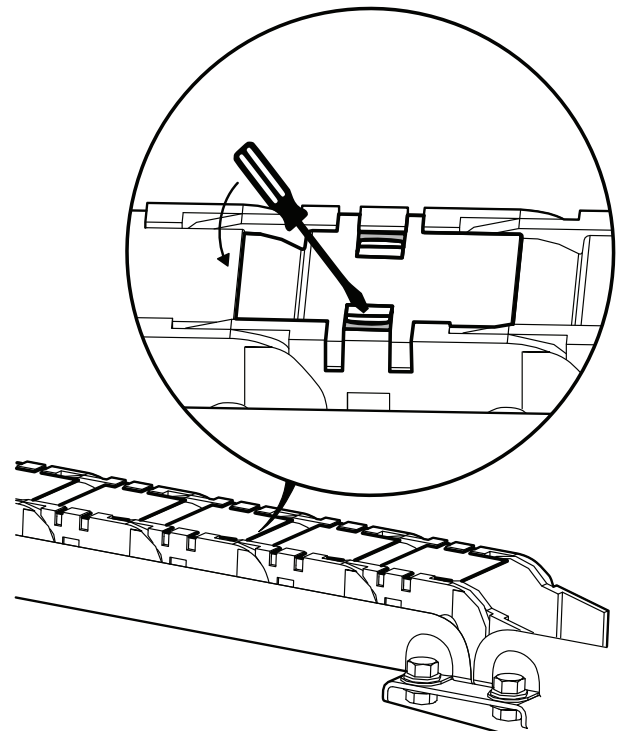

8 Insert the power cable (if you have a electric engine) and the signal cable into the cable holder. Align the cable ends together and make sure that there is at least 60-70 cm of cable extending beyond the end of the holder. Make sure the cables are straight and oriented correctly by placing the biggest, male coded connector beyond the cable holder end, furthest away from the power inlet in step 8. Close the lids again.

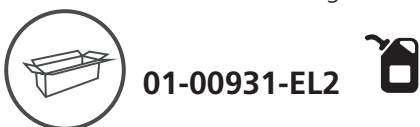

- 1 x 01-01033 (6 m)
 - 1 x 01-00945 (10 m)
- OR -

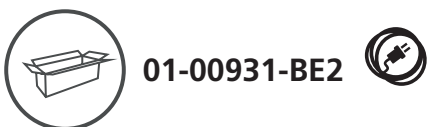
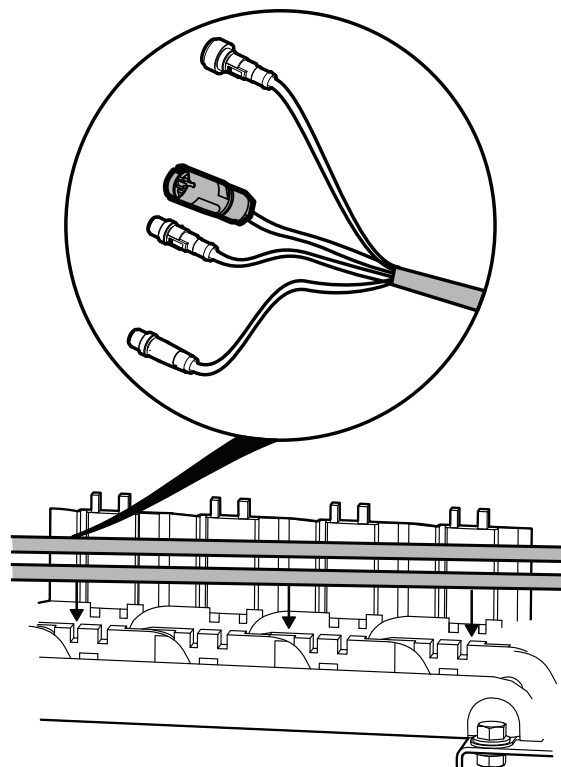

- 1 x 01-01049

9 Attach the inlet holder to the rail pipe edge piece, next to the cable rail base. Skip this step and the next one (9-10) if you have a petrol engine.

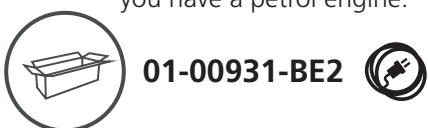

- 2 x M8x16
- 2 x M8
- 1 x 02-00571

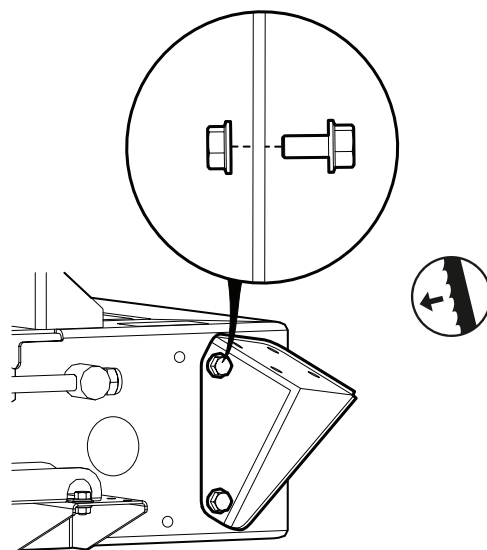

10

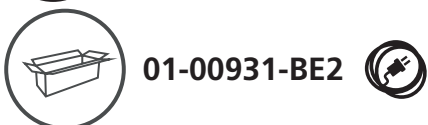

- 2 x M5x20
- 2 x M5
- 2 x 01-01033 (6 m)

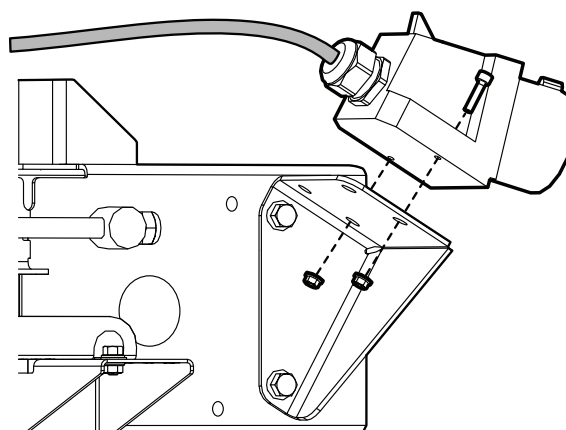

11 Cover up the rest of the cables in the rail base using the protection covers.

2 x



03-03748

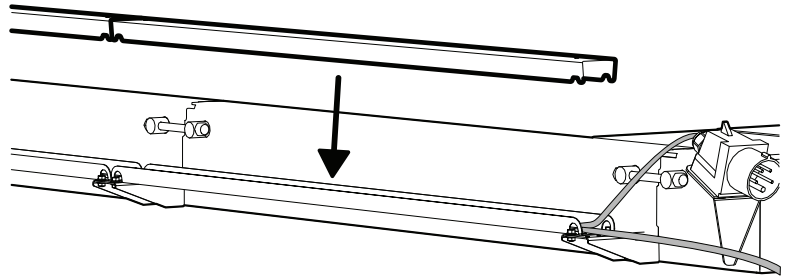

12 Fold the cable holder back up and attach the connector plate. Leave it hanging there until later.

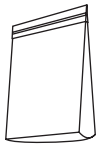

01-00956-SKP

4 x



M6x20

25 x



M6

1 x

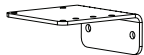

03-03703

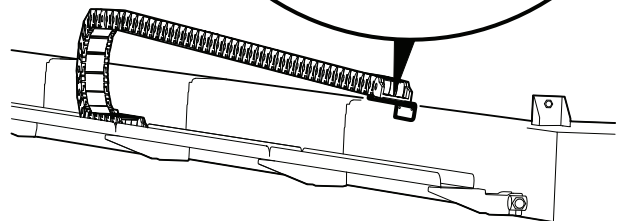
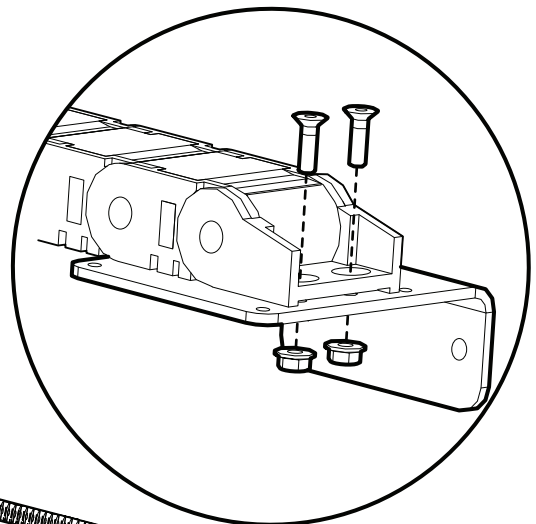





MOUNTING OF THE LOG TENSION PROFILE

1

Fit the log tensioning profiles on the side of the cross bunk with no reinforcement.
We recommend installing the profiles on cross bunk 1 and 3.



01-00937-SKP

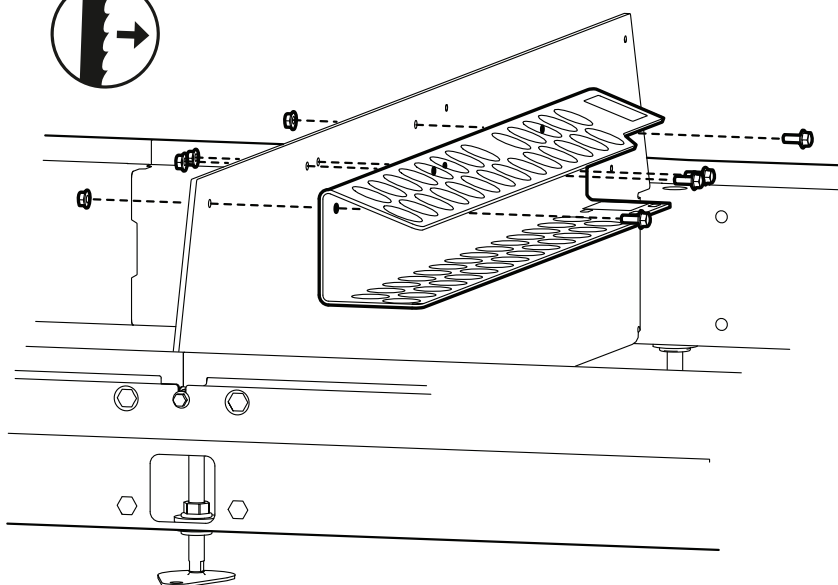

- 4 x  M8x20
- 4 x  M8
- 1 x  03-02642

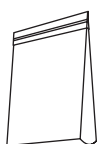

2

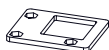

01-00937-SKP
+
01-00937-DIV

- 3 x  M8x14
- 3 x  M8
- 1 x  03-02461

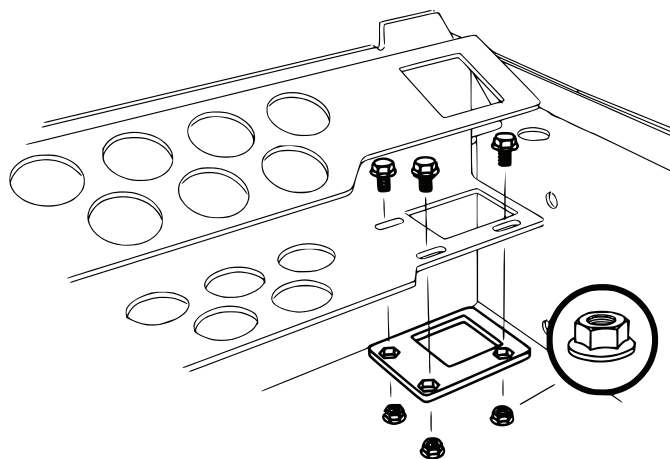

3

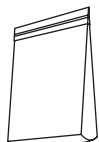

01-00937-SKP
+
01-00937-DIV

1 x  03-02650

1 x  03-03686

1 x  9321-635-3225

1 x  9321-636-1260

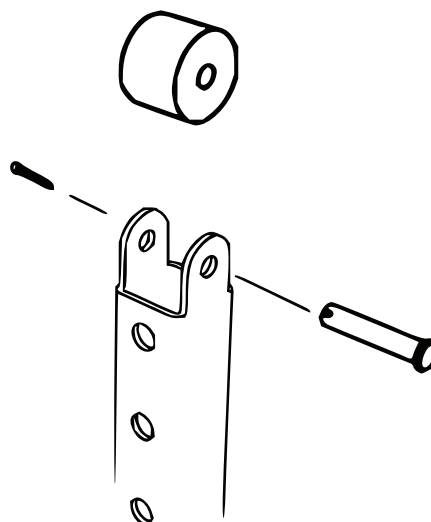

4

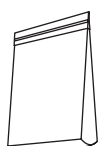

01-00937-DIV

1 x  9321-633-0112

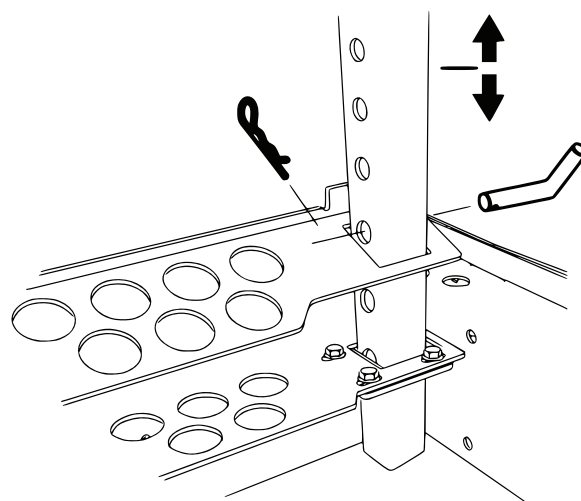

5

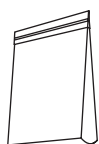

01-00961-PAR

2 x  9291-020-0005
(8.5x12x11mm)

2 x  03-03681

2 x  M8x20

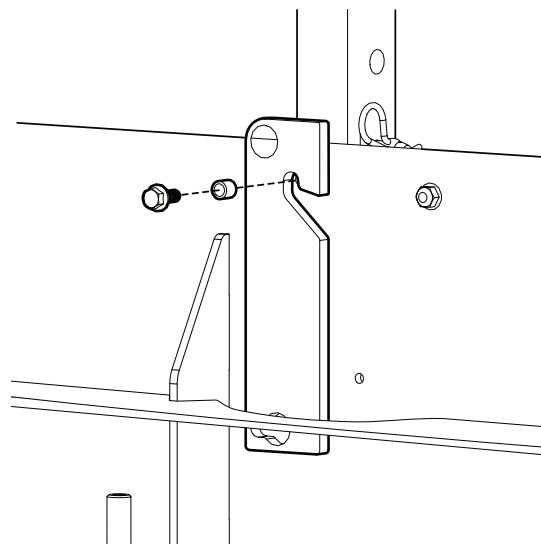

6

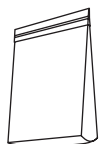

01-00961-PAR

2 x  03-01465

2 x  03-01464

2 x  M8x25

2 x  M8

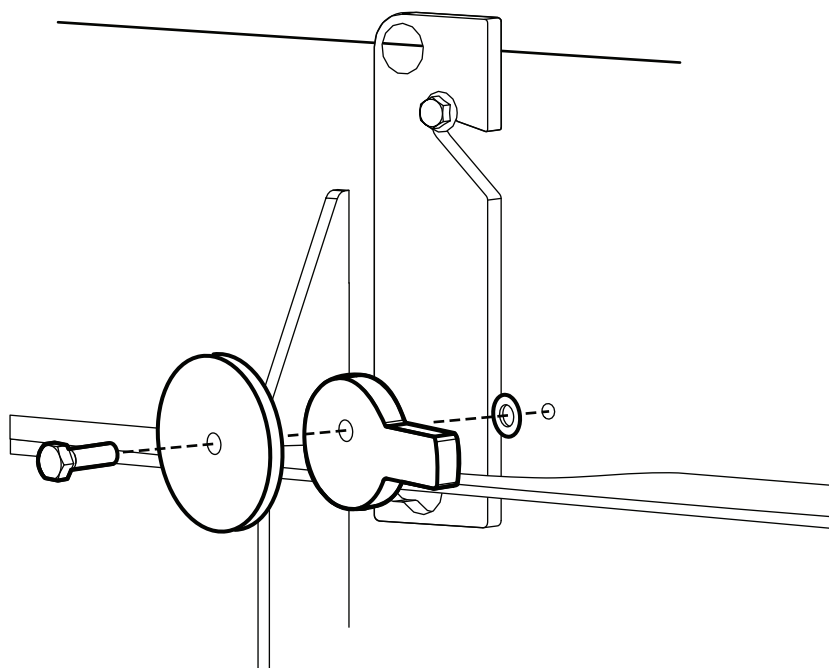

7

Repeat the steps 1-6 for the second log tension profile.

ADJUSTING THE RAIL

Now aim and measure along the string to check that the distance between the string and the rail is consistent along its entire length. To adjust the straightness, move the rail pieces up or down where the straightness deviates.



TIP

Place shims under the rail components so that you can control the height while tightening.



IMPORTANT!

This step is critical to sawmill precision. Be meticulous and spend some extra time on this step.

Once the rail has been straightened, check that all rail joints are even and that the outer rail bars are at the same height as the ones on the inside. The aim is to ensure that all joints are as even as possible. Adjust and tighten the screw joints as you work. Tighten the aligned half of the screw joints for the rail when the rail is aligned over its entire length and the joints are even. Then repeat this procedure on the other side of the rail to complete the adjustment.

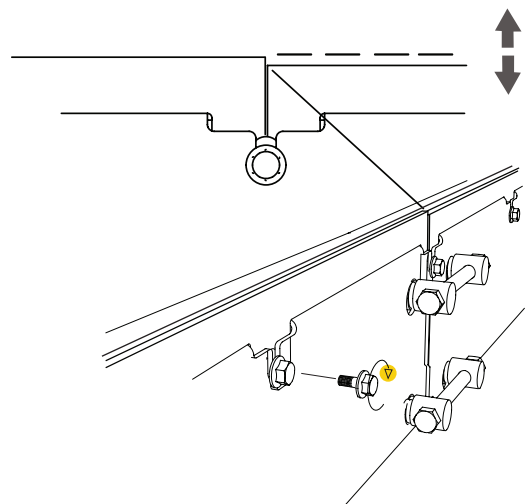
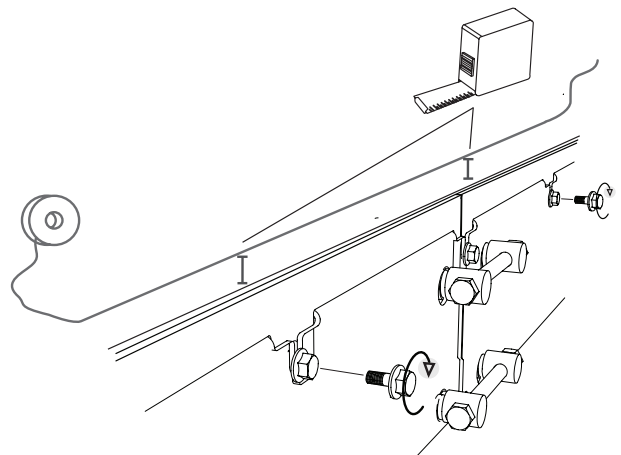
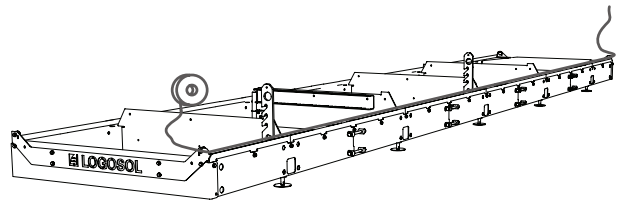
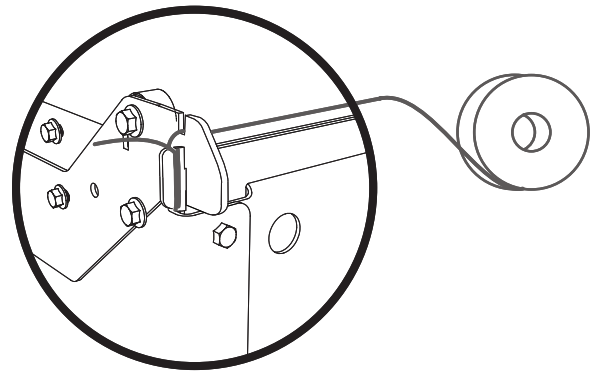

MOUNTING OF THE SAW HEAD ON THE CARRIAGE

Steps 1-7 will be performed on both sides of the carriage simultaneously.



WARNING!
Heavy lifting. Risk of injury.

1

Mount the shroud on the carriage, enter the pylon bushing from above and fasten it from the sides.



01-00942-DIV

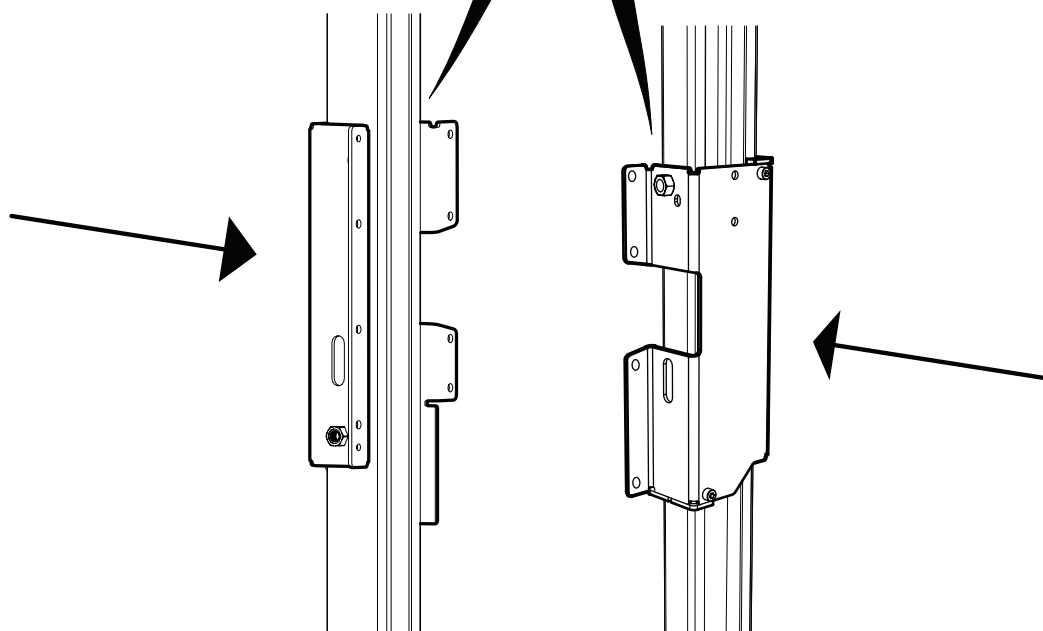
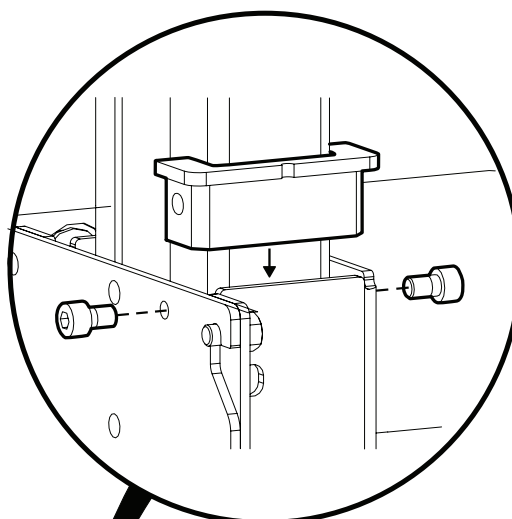
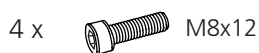
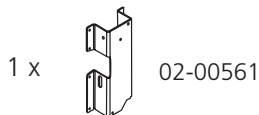

2

Lift the saw head and hang it on the screws.

1 x  01-00942

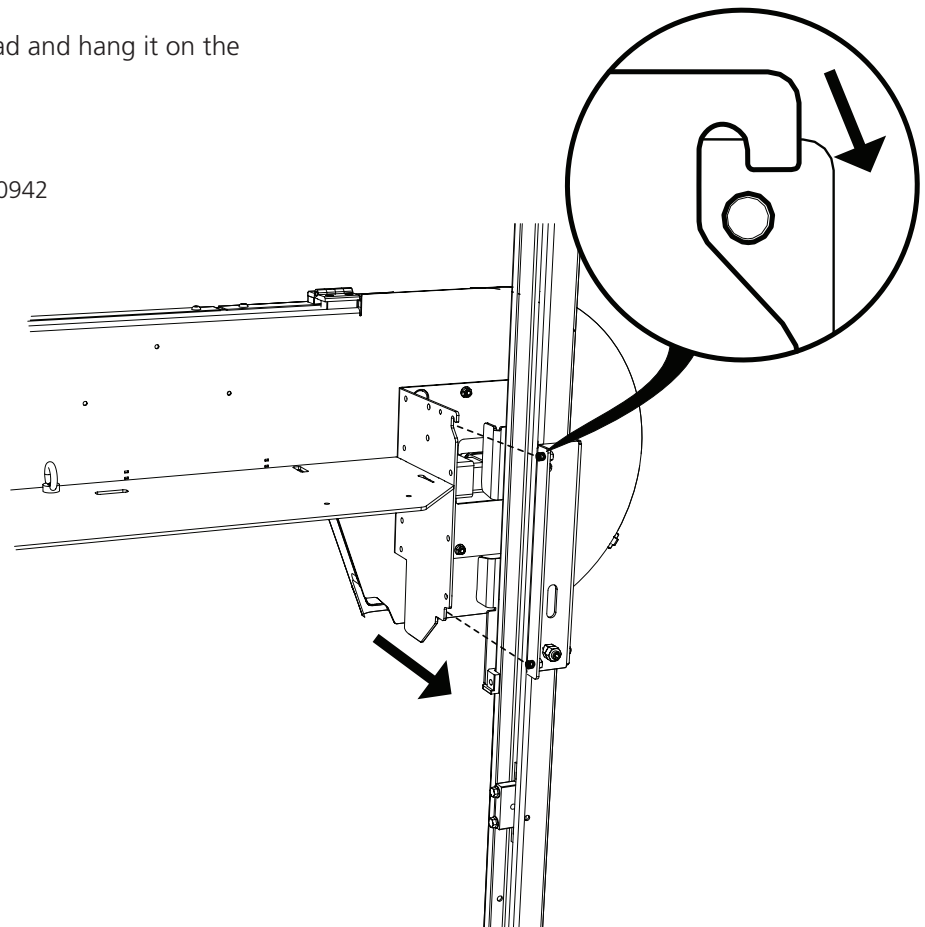

3



01-00942-DIV

7 x  M8x20

7 x  M8

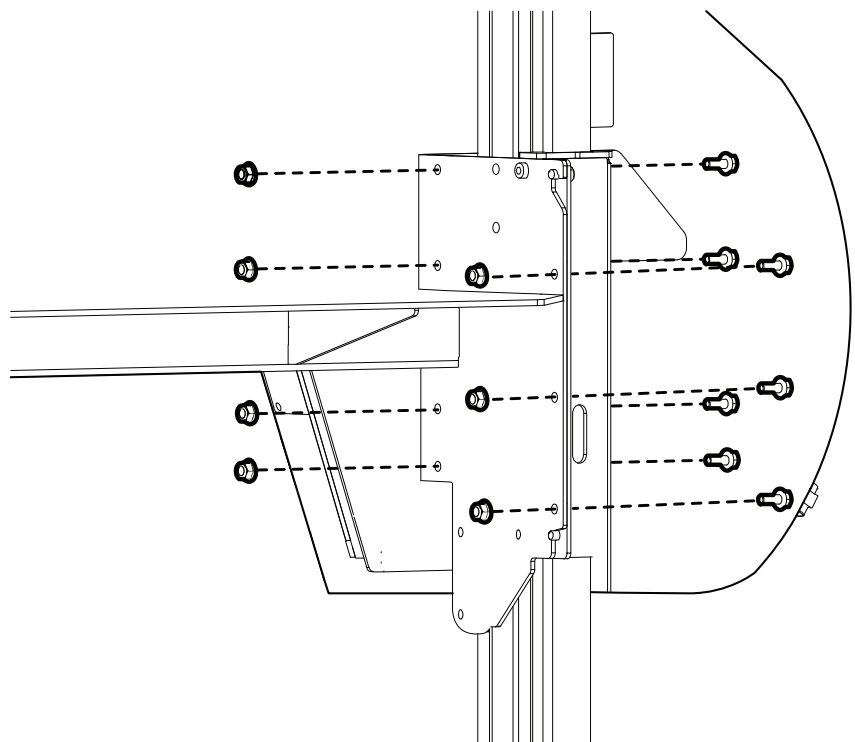

4



01-00942-DIV

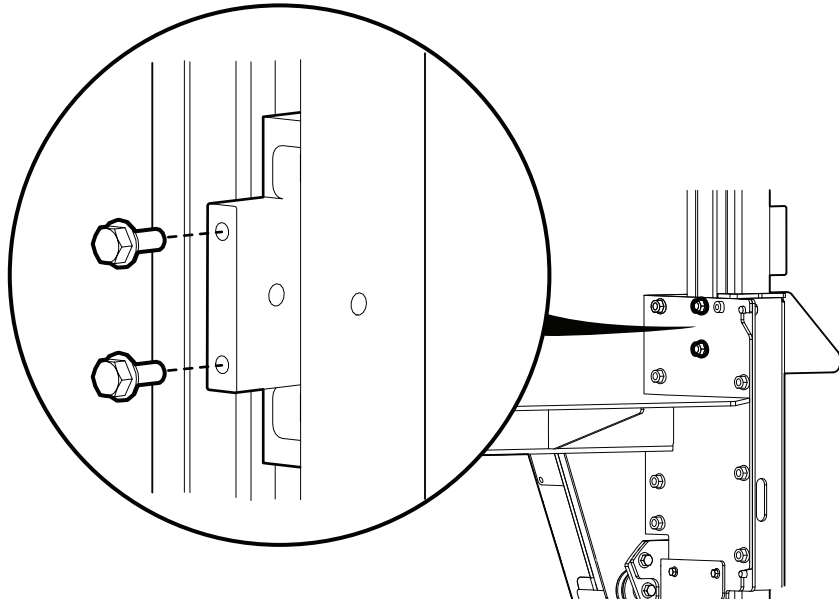

2 x  M8x20



5



01-00747-SKP

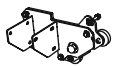

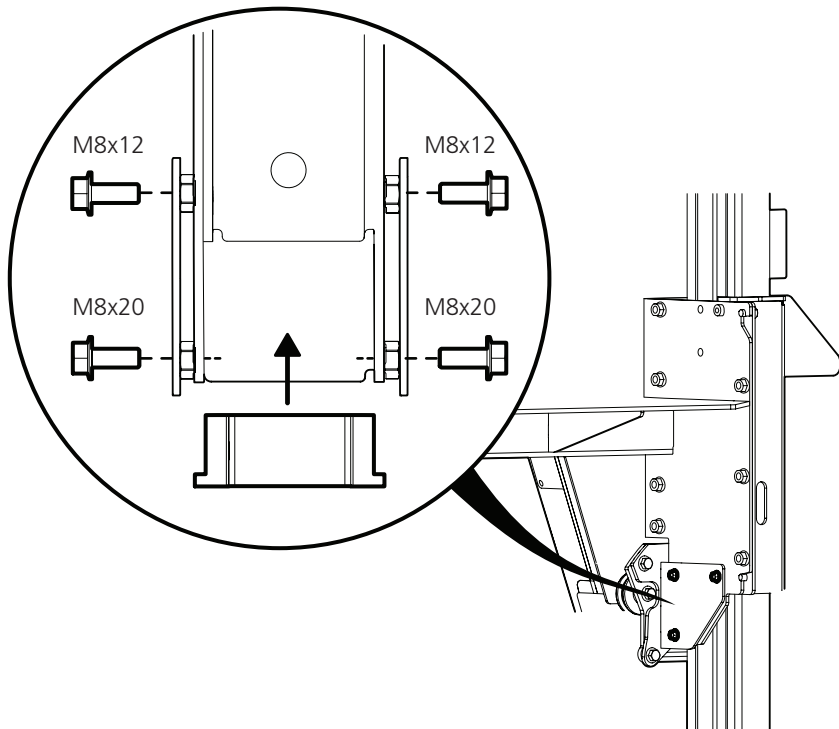
- 4 x  M8x12
- 2 x  M8x20
- 1 x  03-03787
- 1 x  01-00321

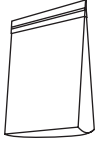

6

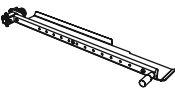

01-00330-DIV

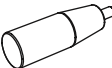
- 1 x  01-00330
- 1 x  M8x25
- 1 x  4900-003-0225

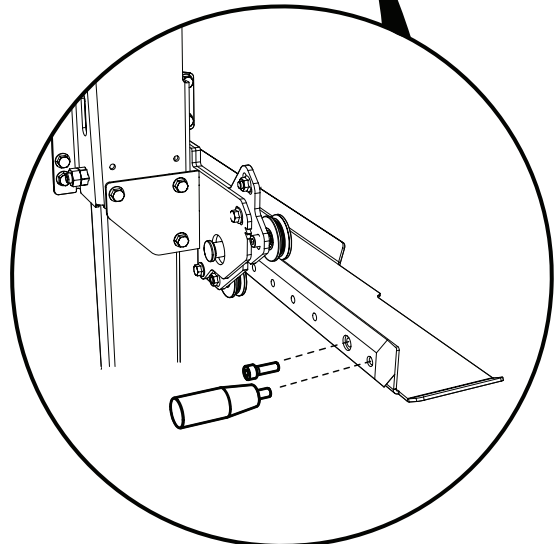
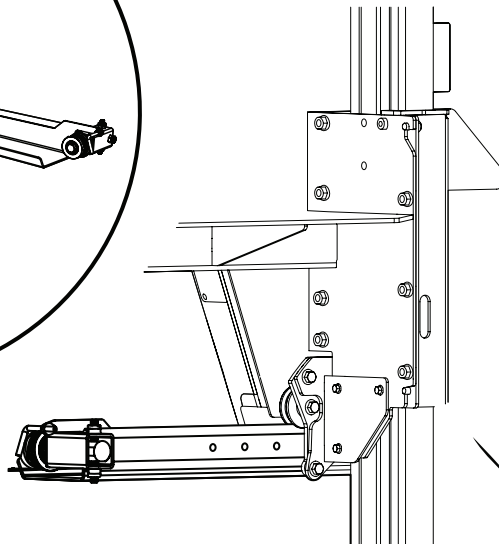
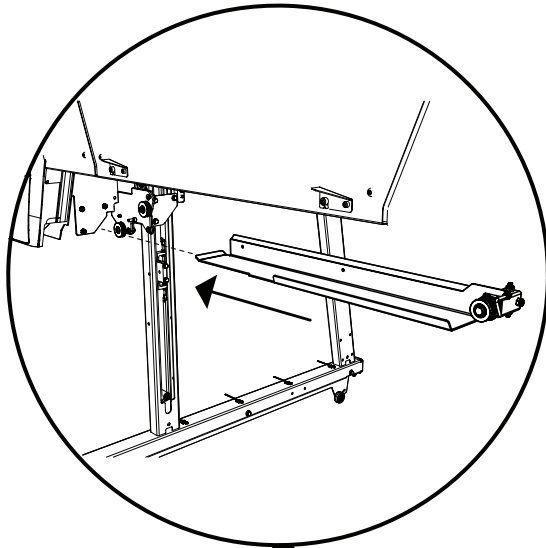

7

Tie the polyester string that is hanging from the top of carriage to the blue hose that is placed on the motorshelf. Attach the hose to the valve on the water tank.

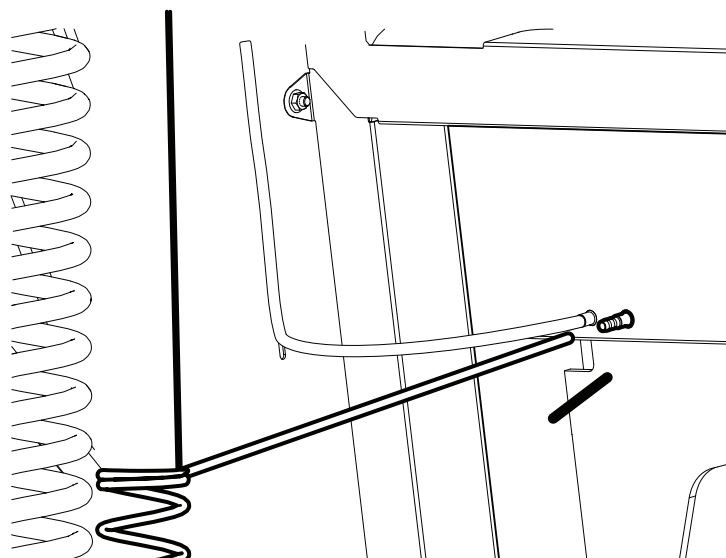

8

Attach the hose to the valve on the motorshelf. String the hose down the hole in the motorshelf and connect at the end of the blade guard.

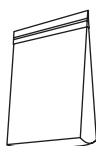

01-00330-DIV



1 x 9038-012-0001 (0,9 m)

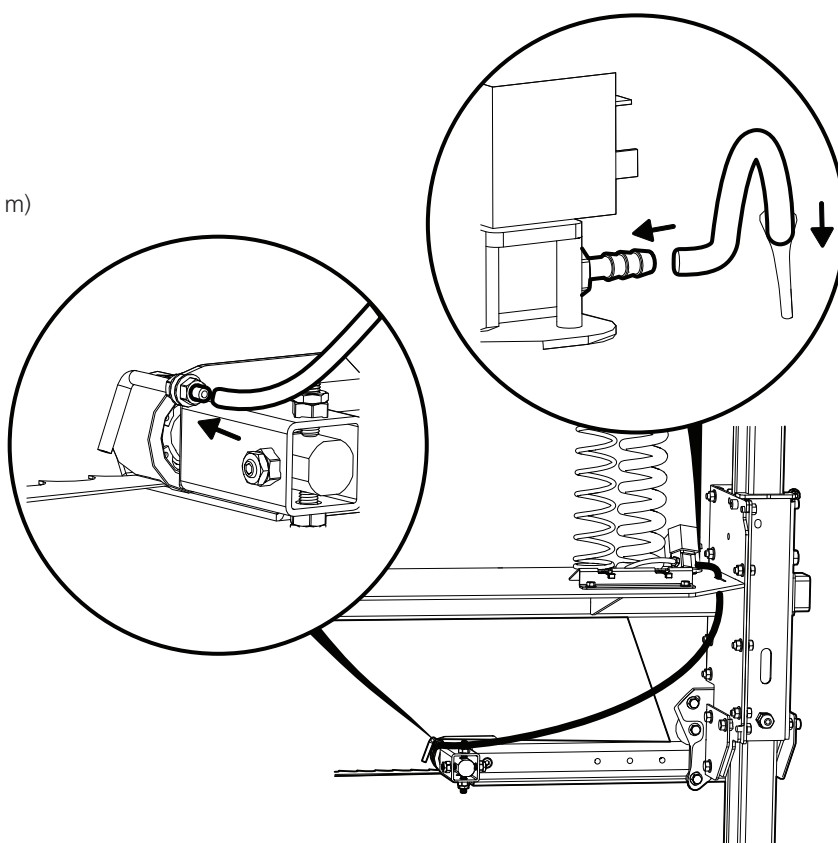



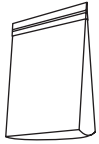

9

Fit the fixed blade guide, select shims as required. Read more under "Order of adjustments", section 5.

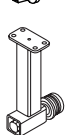

01-00269-DIV

- 1 x  03-01771 (2 mm)
- 1 x  03-01772 (1 mm)
- 1 x  03-01773 (0.5 mm)
- 4 x  M8x16
- 1 x  01-00269

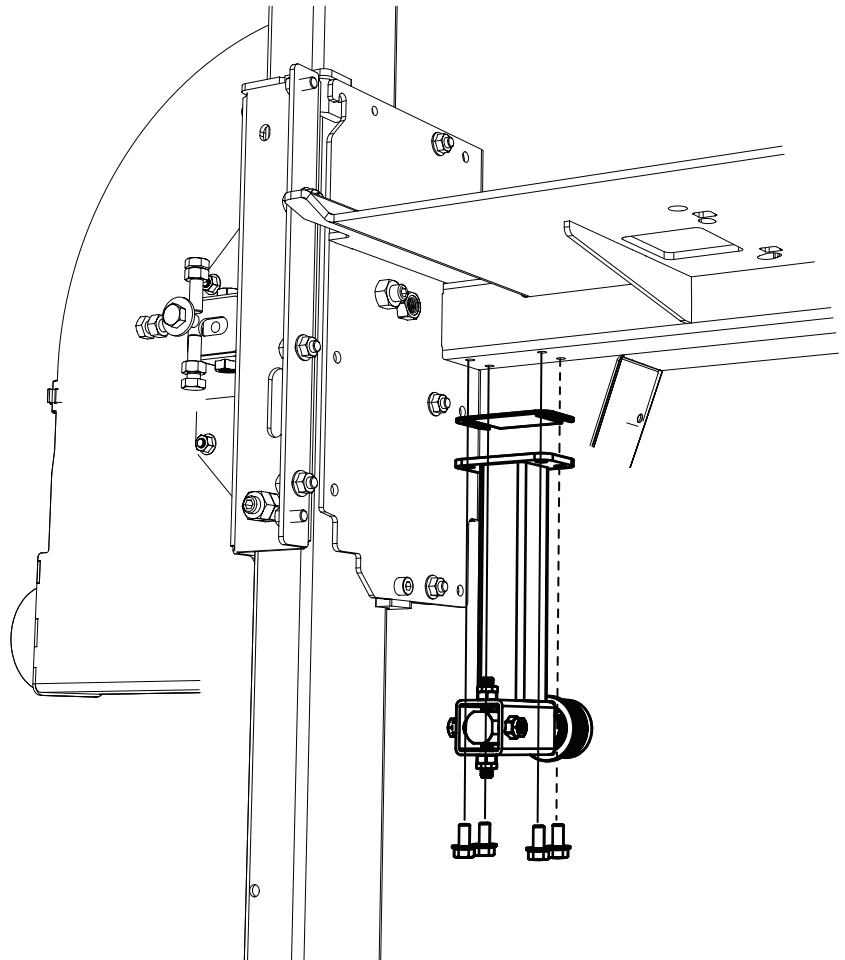

**IMPORTANT!**

It is important to adjust the saw head before starting to ensure satisfactory sawing and the correct functioning of the sawmill.

Carefully follow the adjustment sequence! Certain adjustments affect other machine settings.

**WARNING!**

Overturning hazard! Critical assembly.

**IMPORTANT!**

Take time to ensure that the saw carriage surrounds the rail.

CARRIAGE AND SAW HEAD WEIGHT: 350 KG

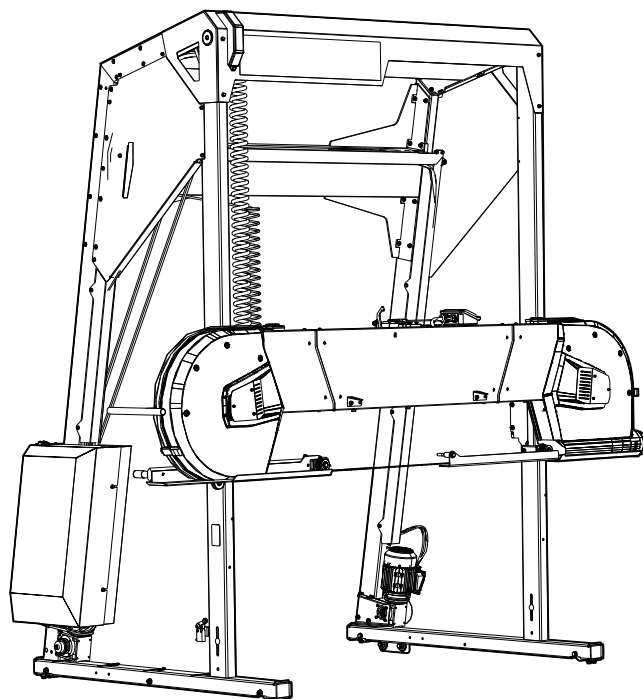

MOUNTING OF THE SAW HEAD ON THE RAIL

Lift the saw head into place on the rail. The saw head weighs 350 kg in total. Use a sling approved for the purpose and attach to the saw head's lifting eyes. Lift the saw head using the appropriate lifting gear.



The anti-tip wheels must be mounted on the underside of the saw carriage when the saw head is mounted on the rail.

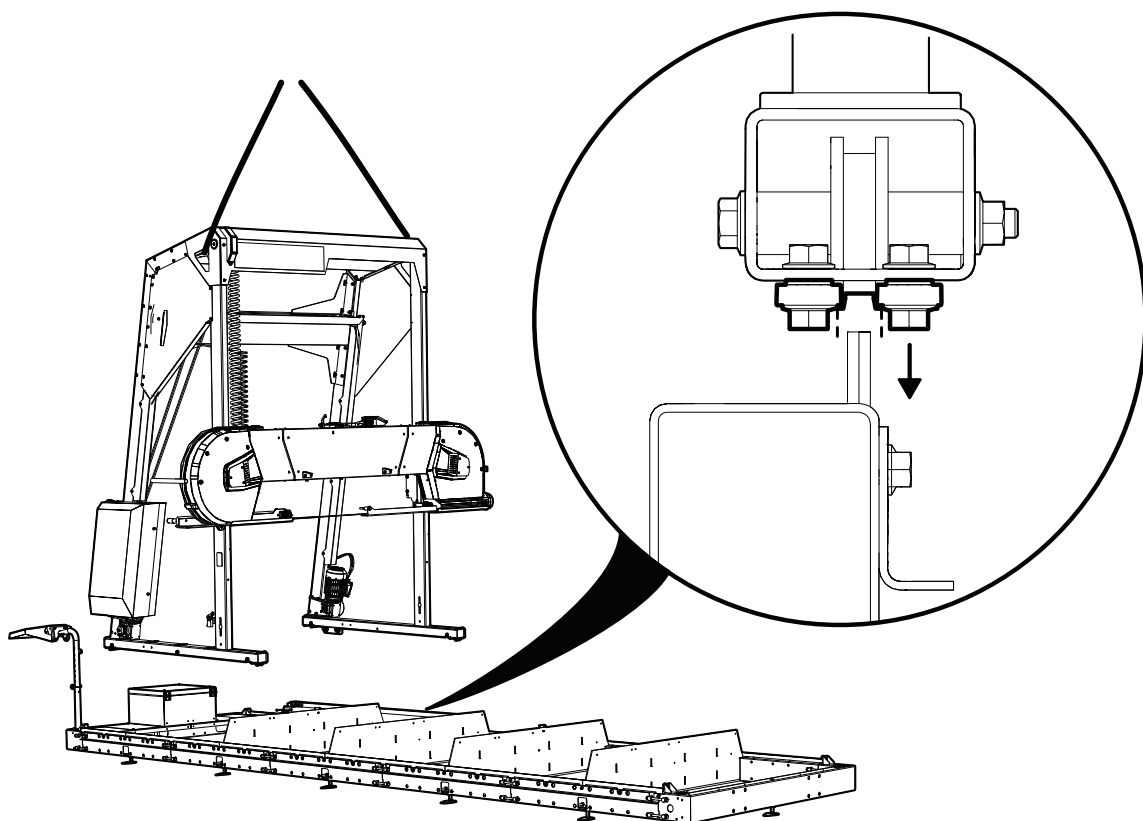

1

Start by removing the flange nuts on the outside of the bogie tube. Leave the bolts where they are. They will be needed for installation later.

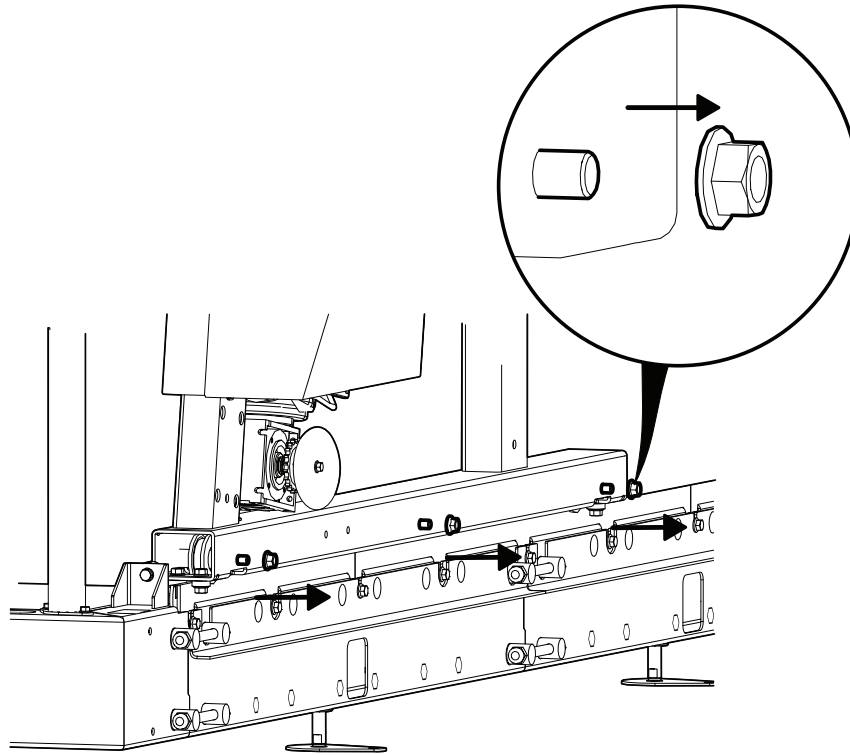





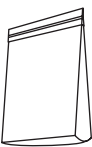

2

Fit the wheels and the cogs to the anti-tip plate.

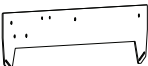

01-00977-DIV
+
01-01006

- 2 x  M10x40
- 4 x  M10
- 2 x  M6x35
- 2 x  M6
- 2 x  04-00063
- 2 x  9029-011-0001
- 1 x  03-03730

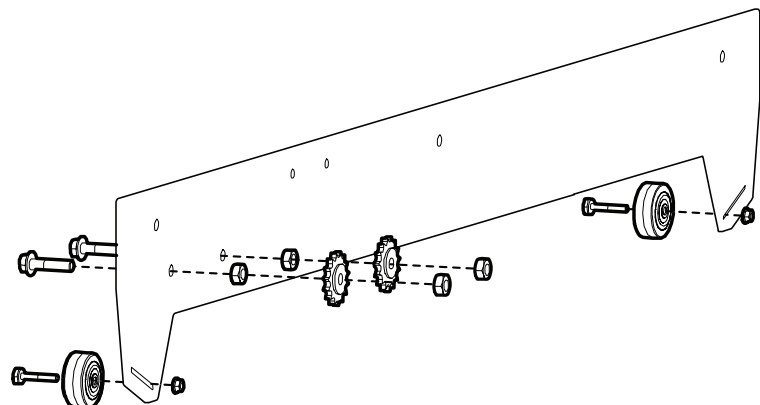

3

Fit the anti-tip plate on the bogie tube and use the existing nuts from step 1. Fit the rail cleaners by the ends of the bogie tube.

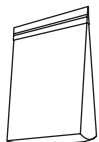

01-00977-DIV

3 x  M10

2 x  03-01982

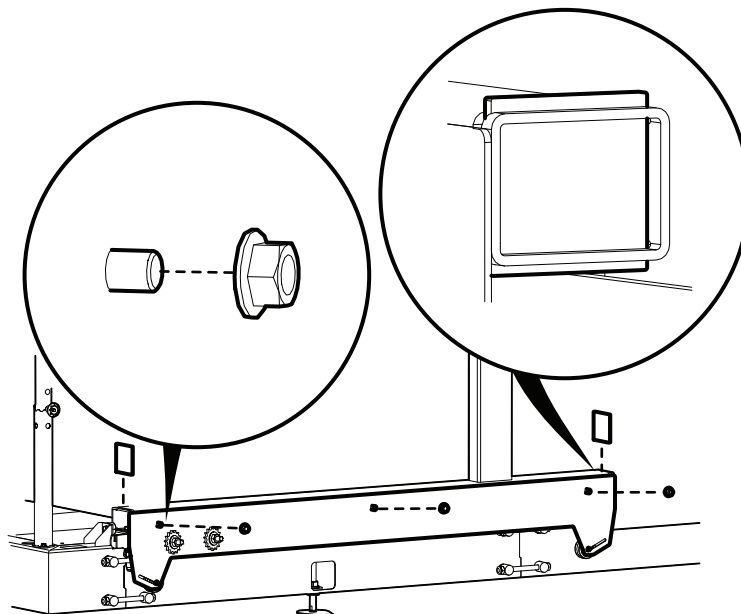

4

Tighten the anti-tip wheels by pushing them upwards in the inclined groove. Move them upwards so that they brace against the underside of the guide bar.

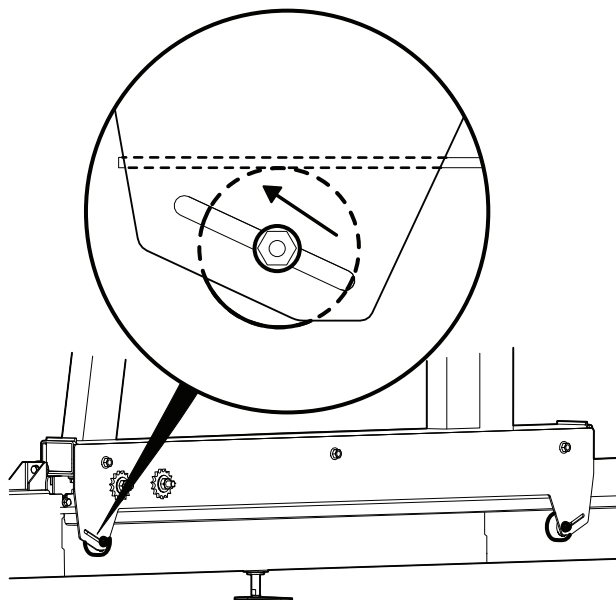

5

Repeat the installation and adjustment procedure seen in step 1-4 for the other side of the machine. Please note that the process will be mirrored.

6

Attach the cable holder connector to the bogie tube.

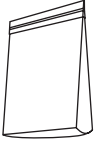

01-00956-SKP

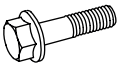
2 x  M8x100

2 x  M8

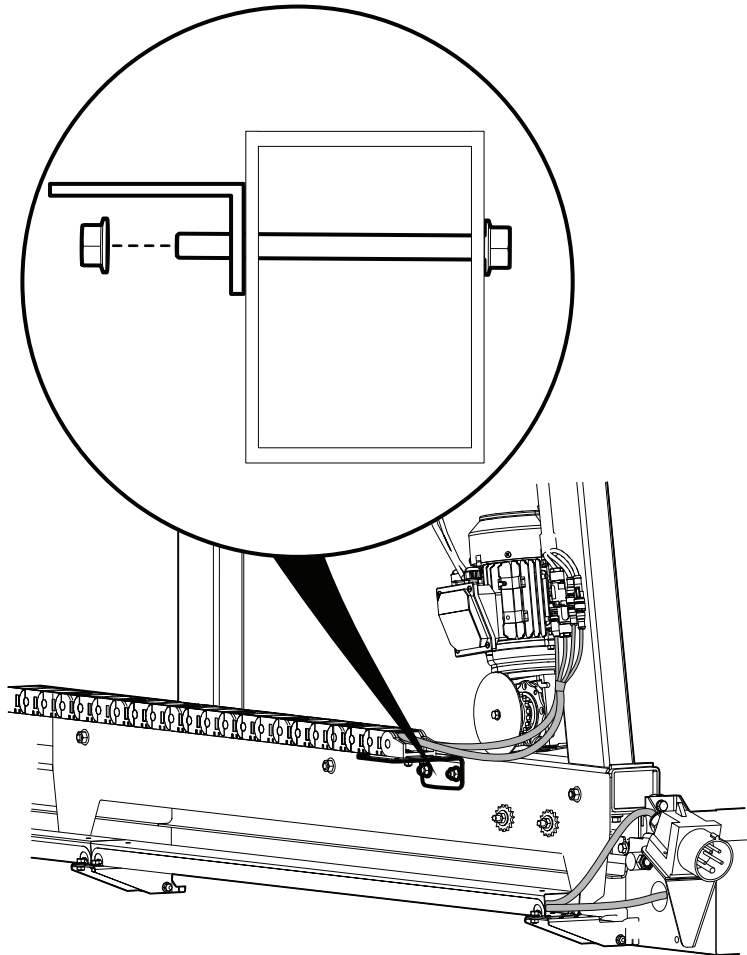

7

1 x  02-00247

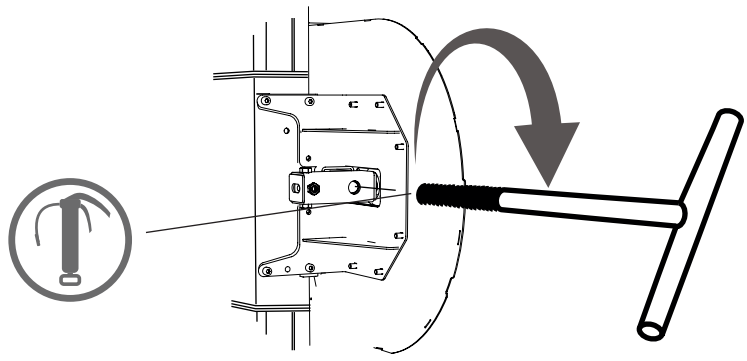

8



01-00931 SB-1

1 x  M6x12

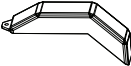
1 x  03-03706

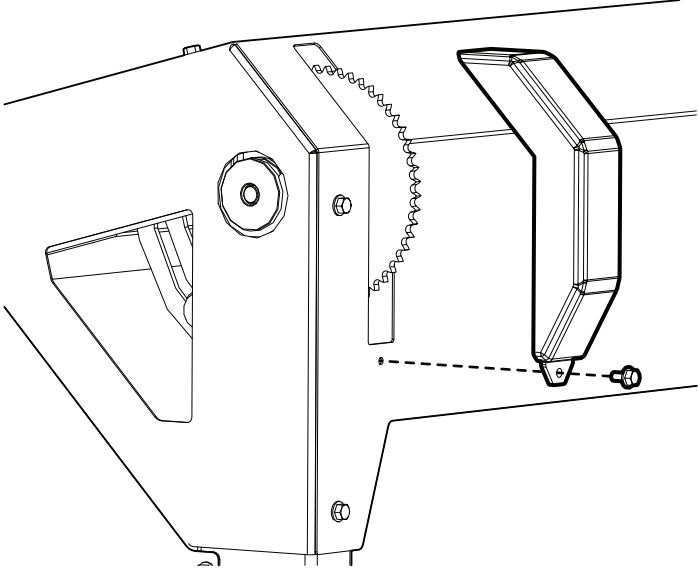

MOUNTING OF THE CHAIN

1



01-00958-DIV

2 x  M8x20

2 x  M8

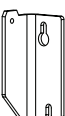
1 x  03-02972

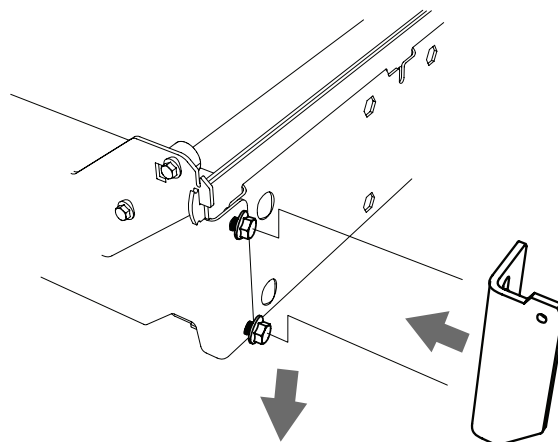

2



01-00958-DIV

2 x  M8x20

2 x  M8

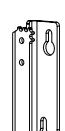
1 x  03-02668

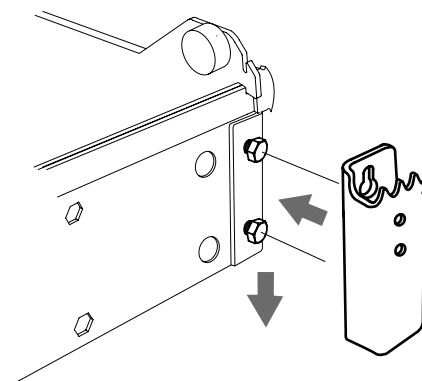

3

Use chain 01-00421. When assembling extensions of the log bed, extension chains 01-00536 should be used, one chain per extension.



01-00958-DIV

2 x  M6

1 x  01-00421

1 x  9023-013-0002

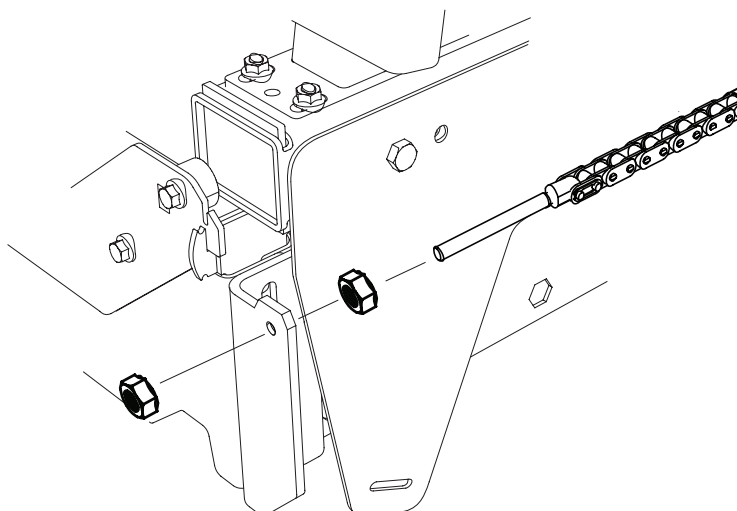

4

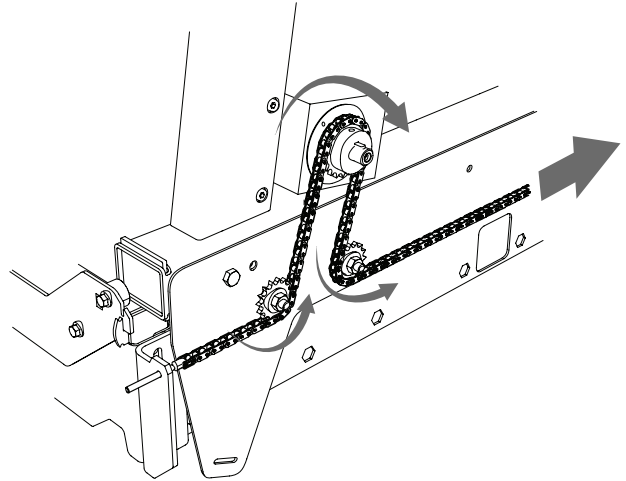

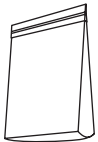

5

Tighten the supply chain manually as much as possible before it is mounted on the chain lock.



01-00958-SKP
+
01-00958-DIV

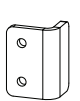

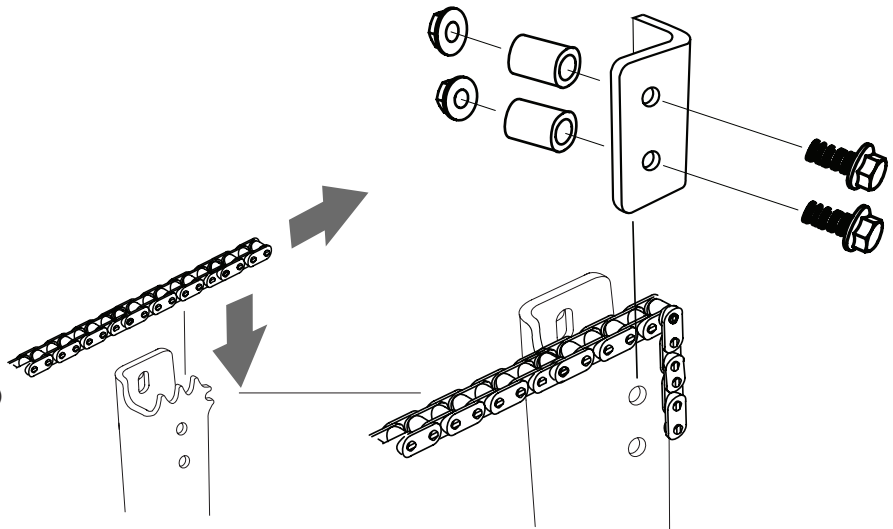
- 2 x  M8x20
- 2 x  M8
- 2 x  04-00443
(6.3x10x10mm)
- 1 x  03-02963

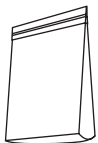

6



01-01006

- 2 x  M10
- 2 x  03-03746

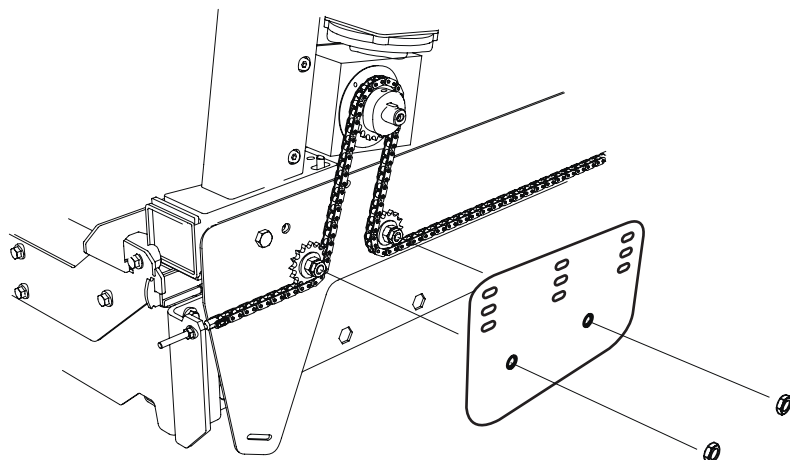

7

Repeat the steps 1-6 for the other side of the machine. Please note that the process will be mirrored.

MOUNTING OF THE FEEDING CABLE

- 1 Insert the signal cable through the hole on the side of the rail pipe.

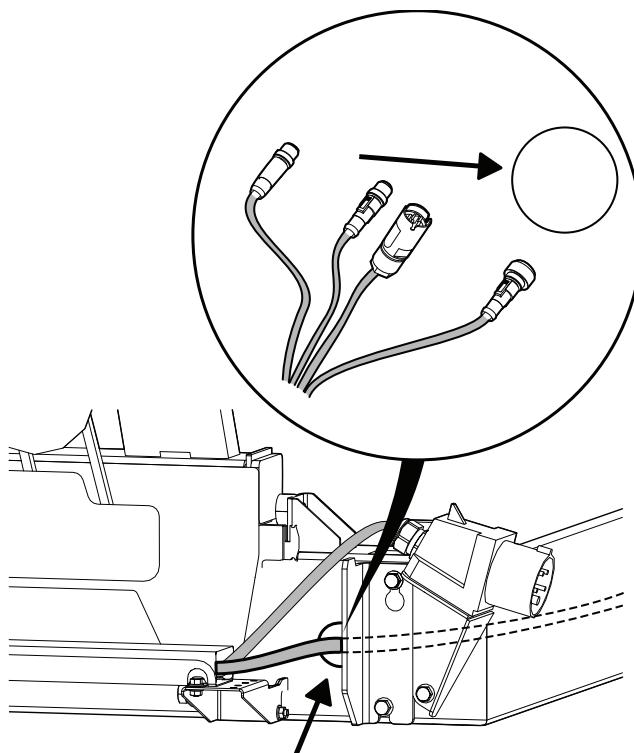

- 2 Pull the signal cable through the rail pipe edge and up through the hole next to the operator panel. Hold the cable in place against the tube using velcro bands.

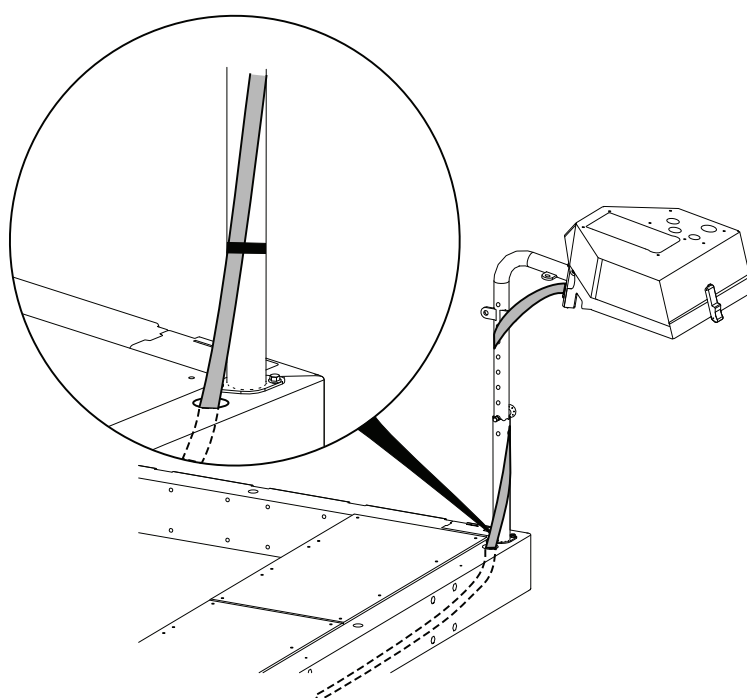

3

Open the operator panel lid and enter the cable from below.

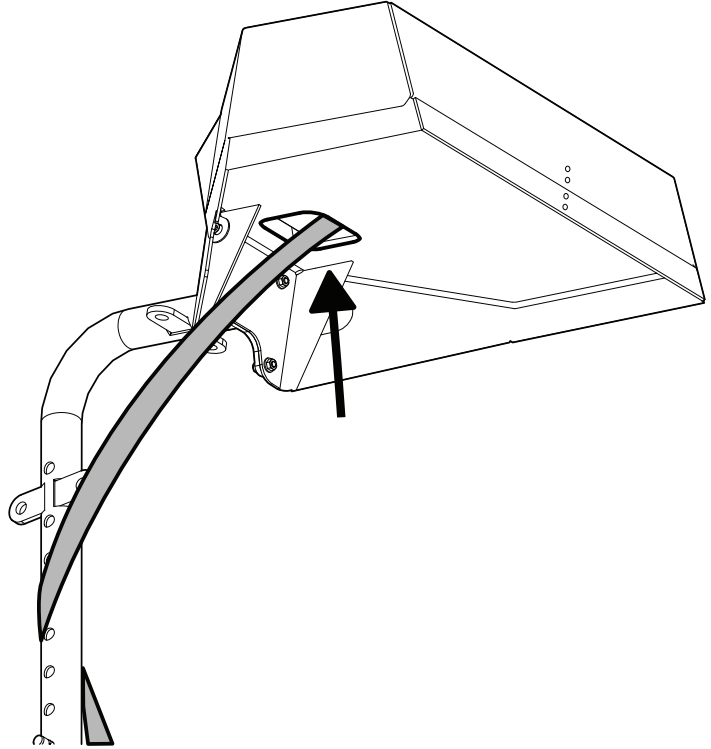

4

Connect the signal cable to the console.

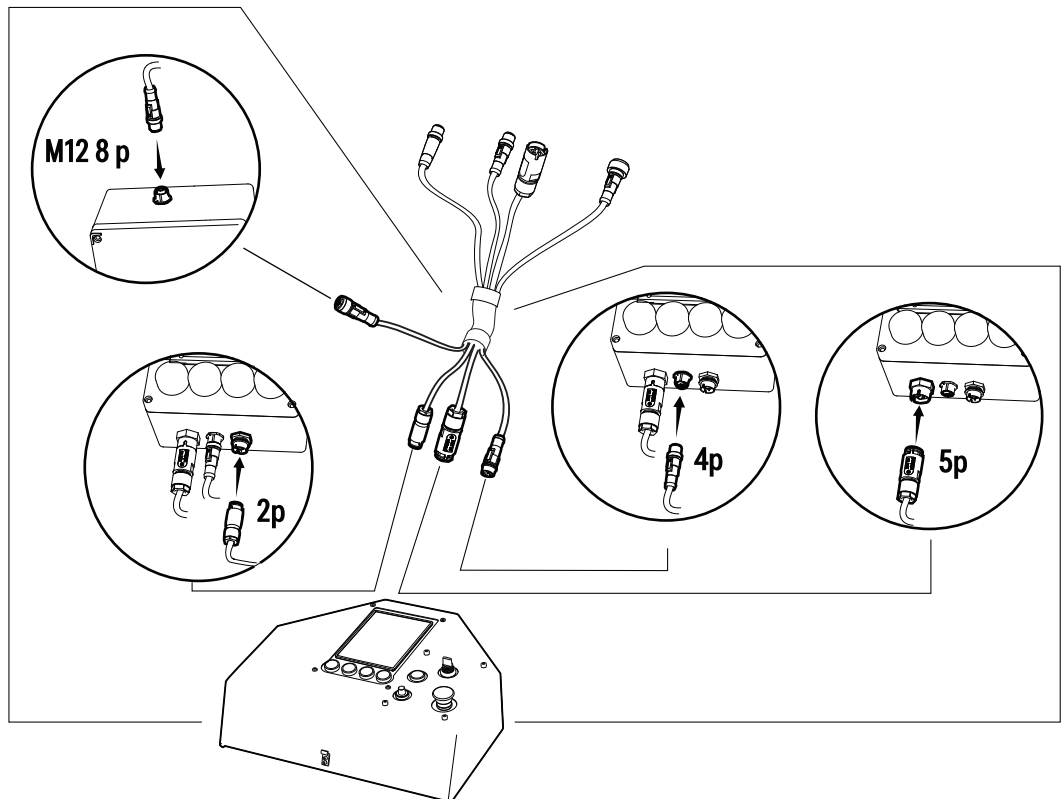

5

Connect the other side of the signal cable to the cables hanging from on the side of the carriage.

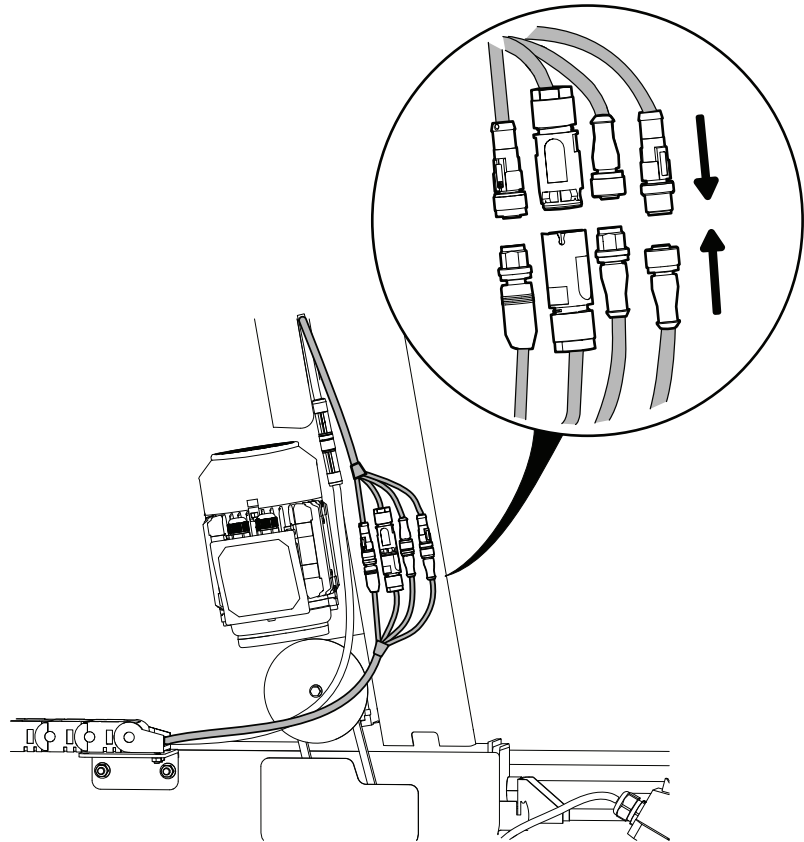

6

Connect the power cable.

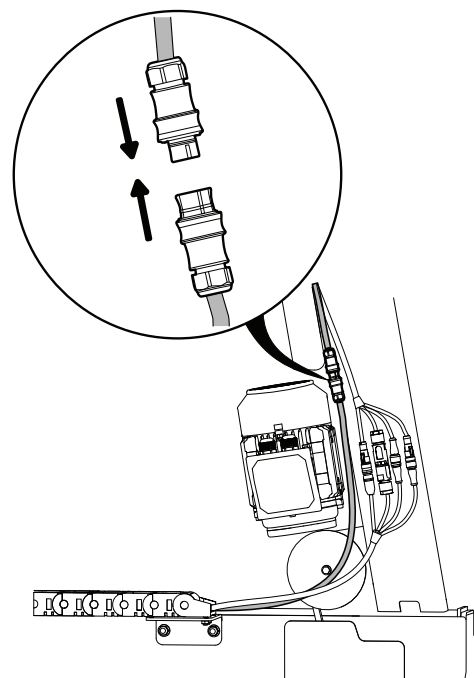

INSTALLATION OF THE PETROL MOTOR: SEE SEPARATE USER MANUAL



It is now time to fit the engine. The instructions for fitting the engine are supplied in a separate attachment: see the instructions for the engine you will be working with.

If you have an electric motor, it is already installed on your sawmill. Skip this step.

When assembly is complete, carry on with the section entitled Adjustment sequence on the next page of this user manual to complete the adjustment sequence before starting the machine.

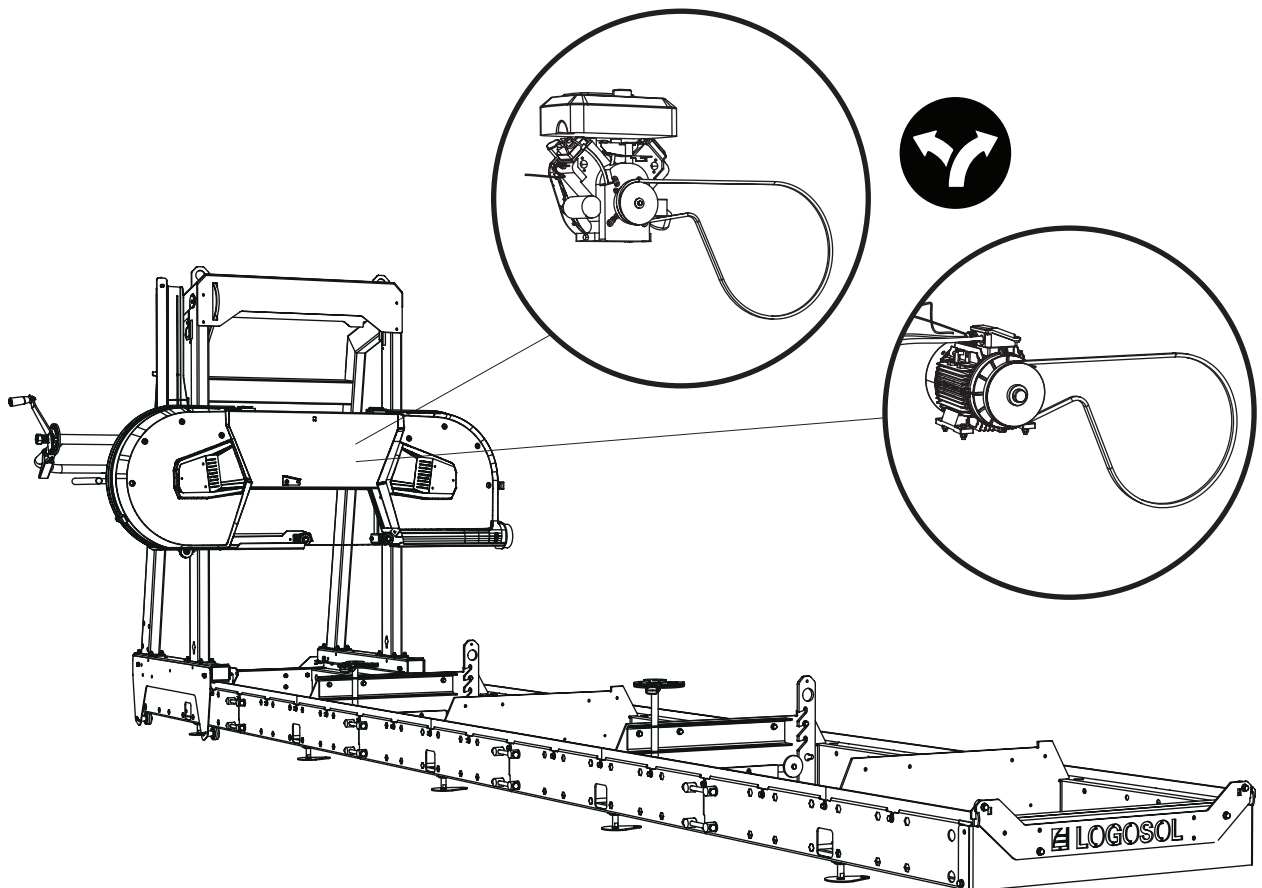

ORDER OF ADJUSTMENTS



Read through all the set-up instructions before starting to set up, then follow the instructions step by step as you work.



IMPORTANT!

It is important to adjust the saw head before starting to ensure satisfactory sawing and the correct functioning of the sawmill. Follow the adjustment sequence meticulously. Certain adjustments affect other machine settings. That is why it is important to follow the sequence below.

- 1 Adjust the rail horizontally
- 2 Adjust the wheels
- 3 Longitudinal blade position / Adjust the longitudinal blade position
- 4 Adjust the saw blade so that it is parallel to the log beds
- 5 Adjust the adjustable blade guide horizontally
- 6 Adjust the blade so that it is parallel to the rail

1

ADJUST THE RAIL HORIZONTALLY

It is important that the rail is completely level so as to ensure that it functions well. We have previously set the straightness of the rail in longitudinal direction. Now the rail has to be adjusted horizontally along the short side. Place a spirit level on a log bed, then adjust the rail using the feet until the rail is horizontal. Then repeat this procedure for all log beds until the whole rail is horizontal.

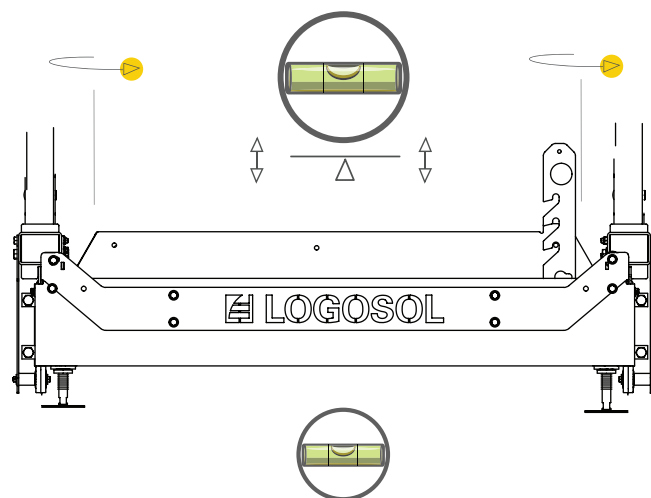

ADJUSTMENT OF THE FEET

The feet can be adjusted from above using an Allen key. Once adjustment is complete, the position is fixed with the check nut on the inside of the tube.

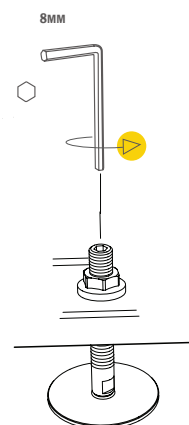
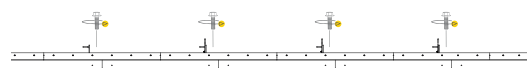

2

ADJUST THE WHEELS

The angle of the wheels must be adjusted so that they are perpendicular to the log beds. With the saw head set to the bottom position, check the perpendicularity between the wheels and the log beds. It is useful to place the angle iron on a straightedge extending between two log beds. Adjust by loosening the lock nut first, then tightening the adjusting screws on the wheel axle until perpendicularity is achieved. Tighten the lock nuts and adjusting screws.

Place the set square on a straightedge

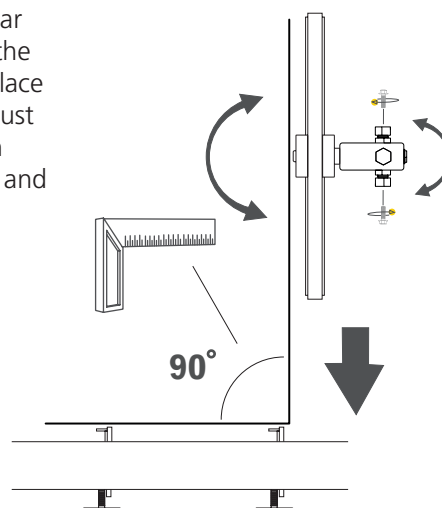
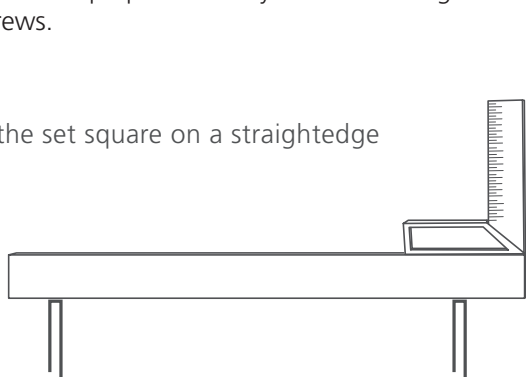

3

LONGITUDINAL BLADE POSITION

The longitudinal blade position over the wheels is adjusted using the horizontal adjusting screws, i.e. the screws on the outside of the axle mountings. The lock nut must be opened first when adjusting the blade position. The adjusting screw must be turned clockwise to compensate if the saw blade wanders forward on the wheels. Turn the screw anticlockwise if the blade wanders backwards. Adjust in small increments. Tighten all lock nuts and adjusting screws when adjustment is complete.

TIP: You may need to loosen the upper adjusting screw slightly before adjusting the blade.

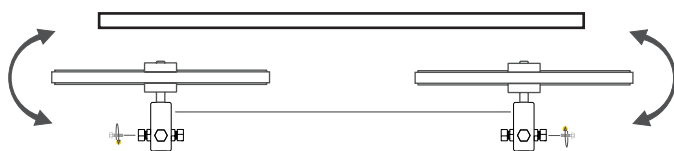

LONGITUDINAL BLADE POSITION

The position of the saw blade in the longitudinal direction is important for the sawing result. Positioning the blade with the blade body centred over the drive belt located in the recess in the wheel is recommended for best results.

Start by fitting the blade so that the protrusion on both sides of the drive belt to the sides of the blade body are of the same size. Then tension the blade. Spin the wheels manually and check that the longitudinal blade position on the wheels remains unchanged. Spin the wheels through at least three revolutions. Perform adjustment as instructed in the next paragraph if the blade wanders forward or back on the wheels. If the blade runs straight on both wheels, check that the blade runs in a straight line between the wheels. This is checked by looking along the trailing edge of the blade on the top of the wheels.

When the blade is running in a straight line. Close the covers and start the sawmill. Open the throttle so that the wheels start to turn, then release the throttle. Open the covers and check that the longitudinal position of the blade is unchanged. If so, the setting is correct.

Loosen the locking screw

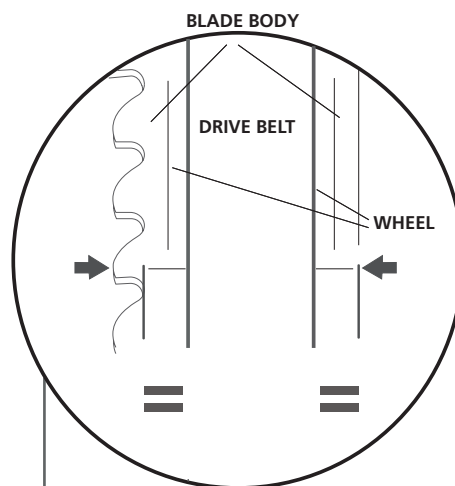
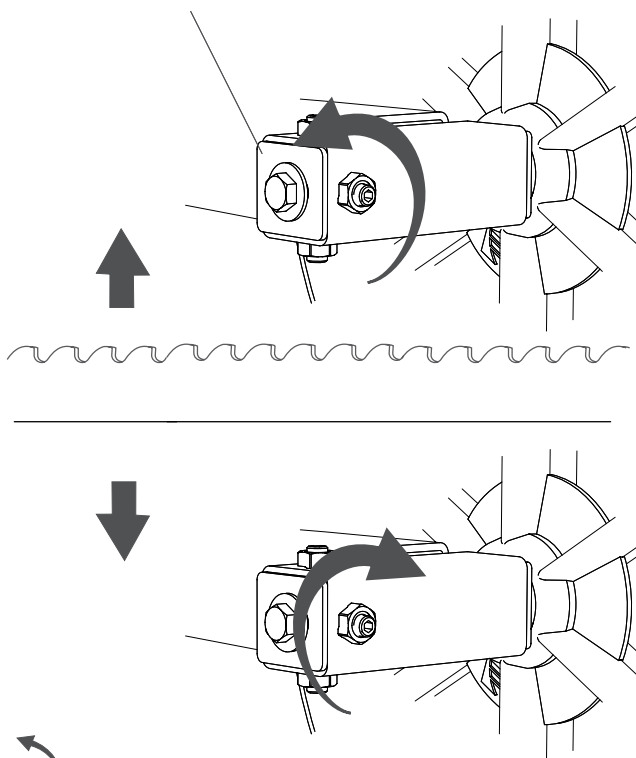

In this case, the blade body is defined as the part of the blade that is between the bottom of the tooth and the trailing edge of the blade.

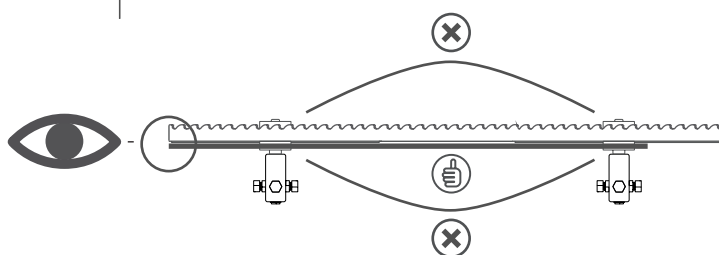

If the blade curves in the sawing direction, the blade is too far forward on the wheels. If it curves in the other direction, it is too far back.

4

ADJUST THE SAW BLADE PARALLEL TO THE LOG BEDS

It is important for the saw blade to be parallel to the log beds to ensure the proper functioning of the sawmill. Measure the distance vertically down from the blade to the log bed, then note down the values.

It is important for the blade guide rollers to be removed for this setting operation.

Adjust the measurement difference between the measurement points. Tighten the saw head adjusting screws until the measurements match at both measurement points.

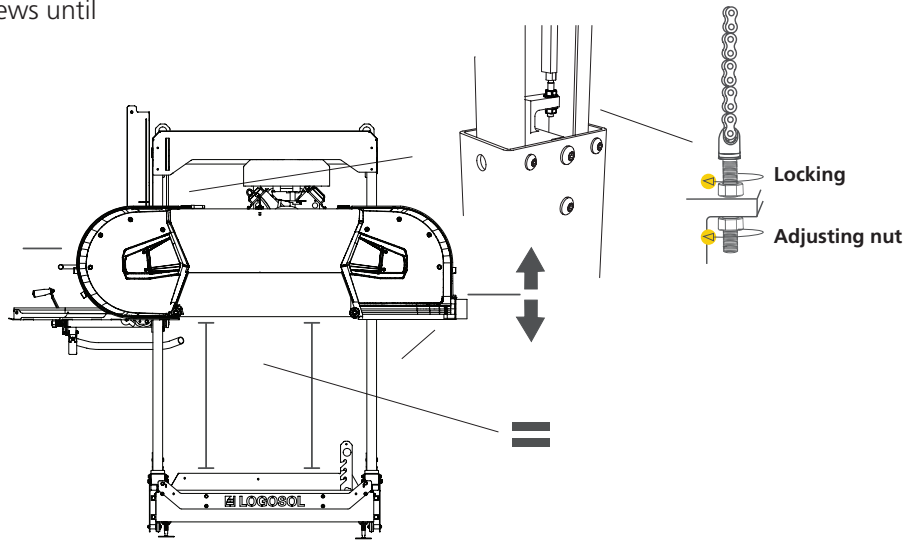
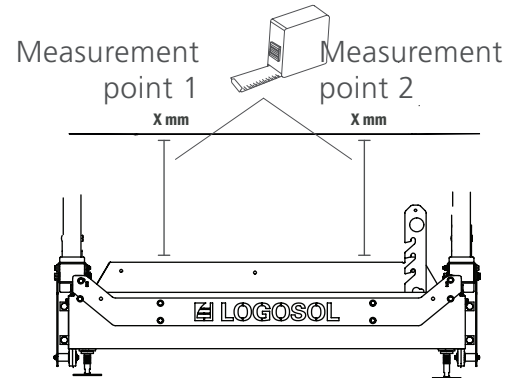

5

ADJUST THE ADJUSTABLE BLADE GUIDE HORIZONTALLY

The adjustable blade guide and guard needs to be adjusted so as to achieve straight kerfs in all positions. Install the blade guide rollers. Then move the blade guide and guard to its innermost position. Place a spirit level on top of the blade guide, then adjust until the blade guide and guard is horizontal. When this has been done, shim the fixed blade guide roller until the same dimension is achieved between the blade tension rollers and the log bed.

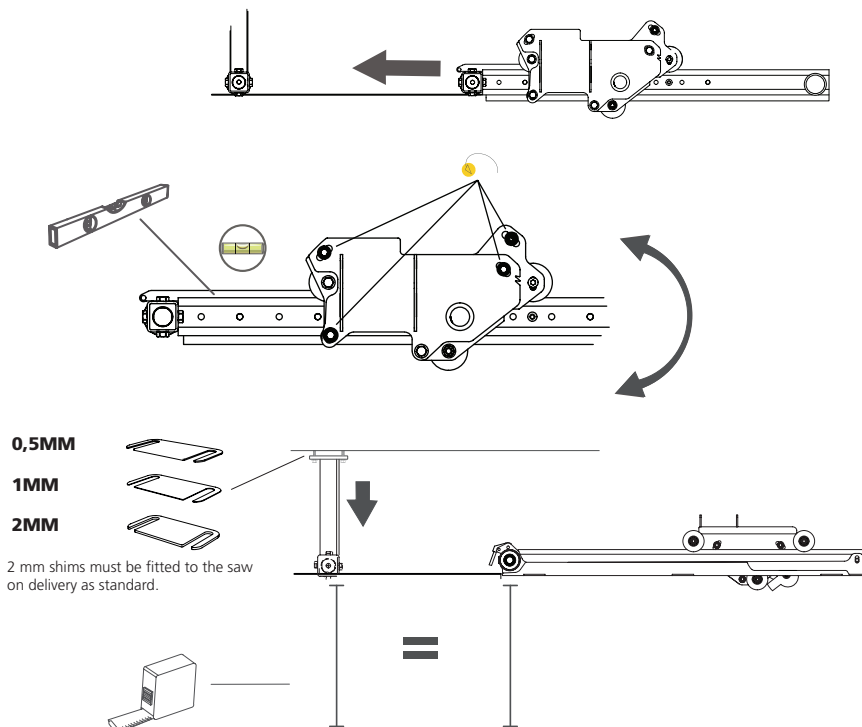

TENSION THE BLADE GUARD ARM

It is important for the blade guard arm to move smoothly in the attachment plate to ensure proper functioning of the sawmill. Release the Allen head bolt on the blade guard plate, then push the wheel downwards using a screwdriver as illustrated. Take care to ensure the blade guard arm is straight between the wheels and runs smoothly.

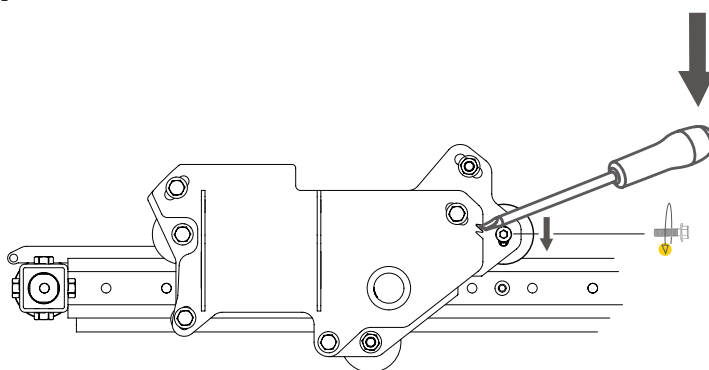

ADJUST THE BLADE GUARD ARM PARALLEL TO THE BLADE

To adjust the parallelism of the blade guard arm with the saw blade, loosen the three fastening screws on the outside of the attachment, then adjust the parallelism using the adjusting screw that attaches to the back cover.

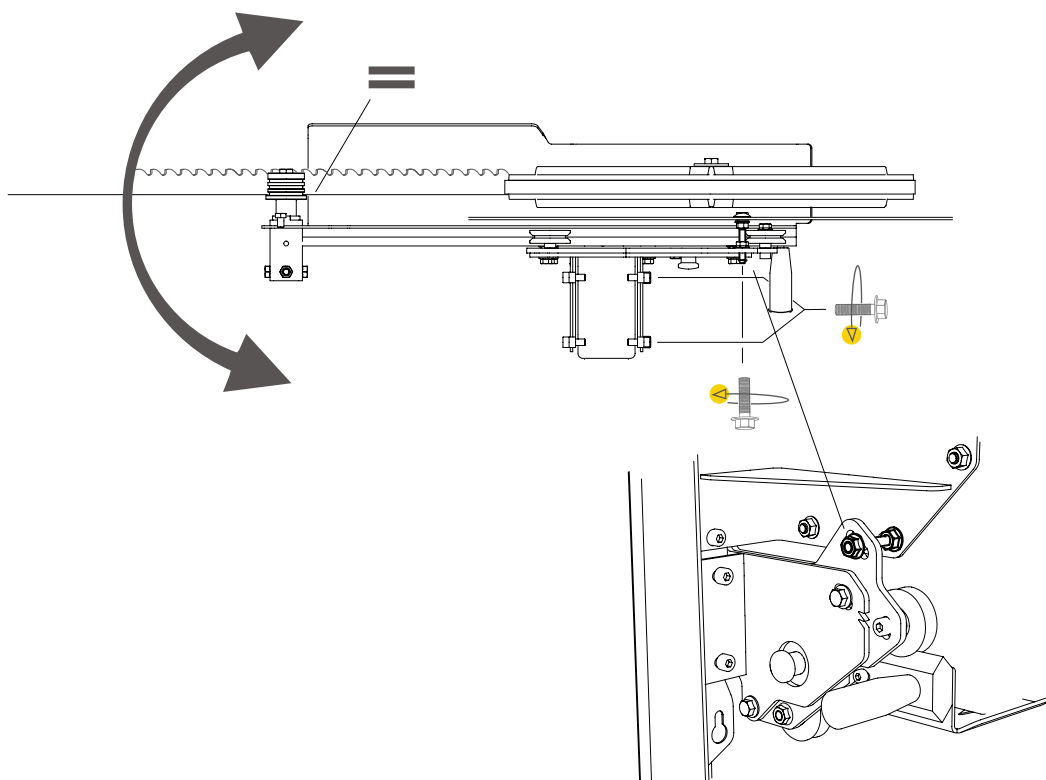

ADJUST THE FIXED BLADE GUIDE AND BLADE GUARD - LEFT SIDE

When sawing smaller sized logs the blade guide on the left side of the machine needs to be adjusted for better results. Remove the bolts at its top and front and move the blade guide to the inner hole section. Attach it with the same bolts you just removed. Lift the blade guard in place and fasten it in the at both ends.

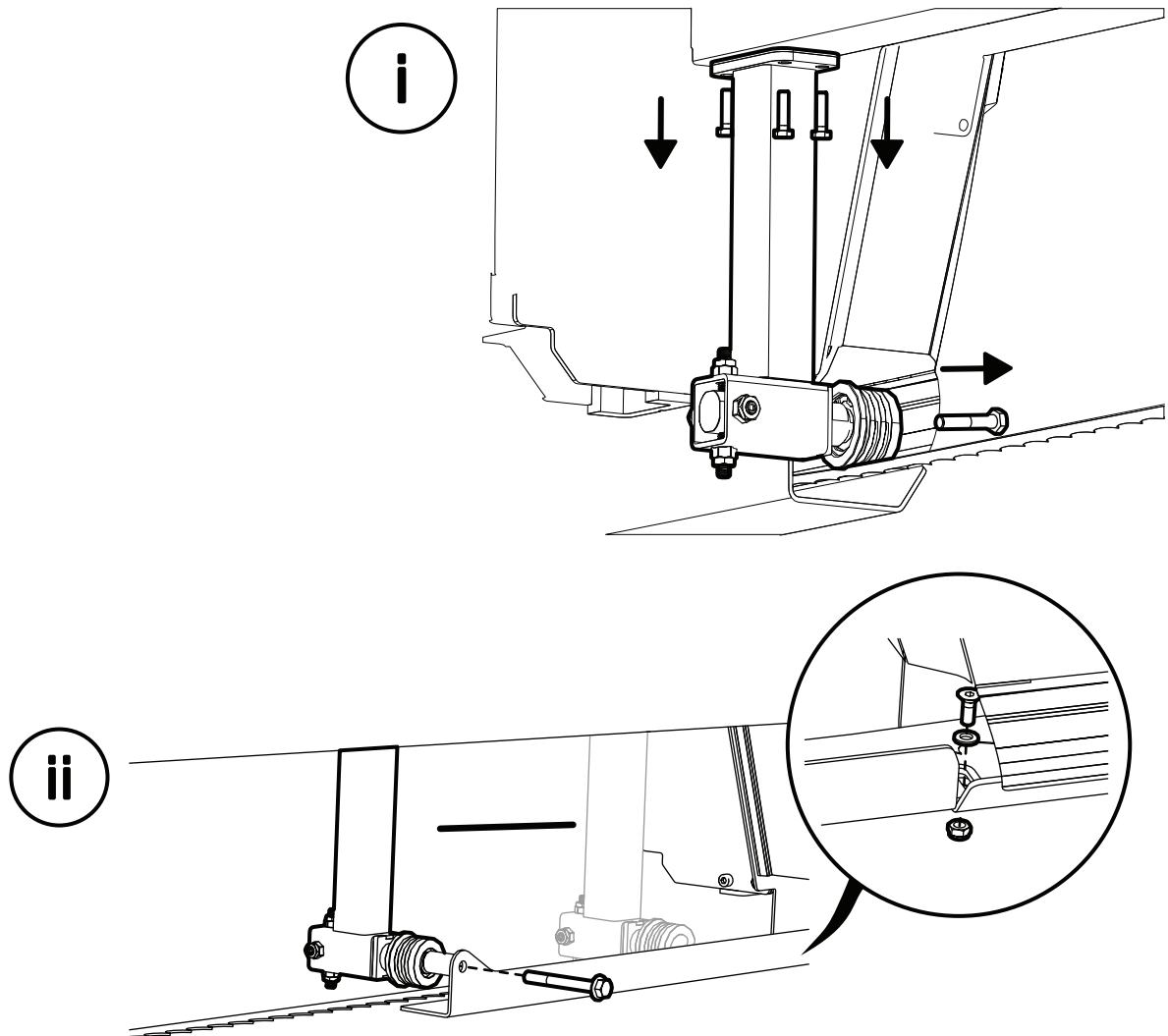

6

ADJUST THE BLADE SO THAT IT IS PARALLEL TO THE RAIL

It is important for the saw blade to be parallel to the rail to ensure proper operation of the sawmill. Place the Blade Align on the saw blade, as close to one of the blade guide rollers as possible. Place the Blade Align over a tooth with no set. Now measure from the leading edge of the Blade Align (measurement point 1) vertically down to the log bed. Note down the value from measurement point 1. Move the saw head, then repeat the measurement from the trailing edge of the Blade Align (measurement point 2). Compare the values. The values at measurement point 1 and measurement point 2 must be the same.

If the values are not the same, tighten the adjusting screws for the blade guide roller until the measurements match at both measurement points. One way of facilitating adjustment is to work on the basis of the value from measurement point 1, compare it with the value from measurement point 2, and then adjust measurement point 2 up or down by half the difference. When you have achieved parallelism, repeat the adjustment procedure at the second blade guide roller.

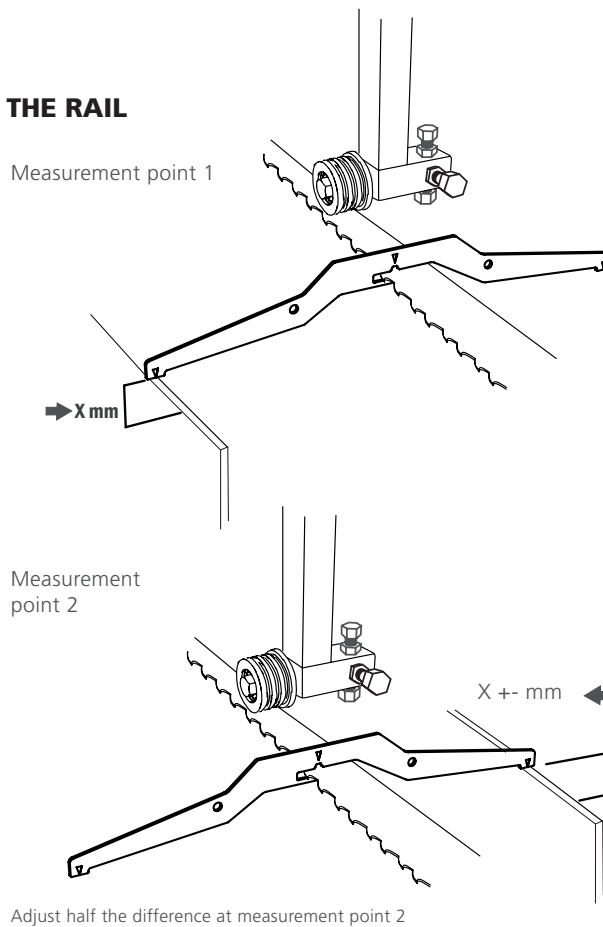

7

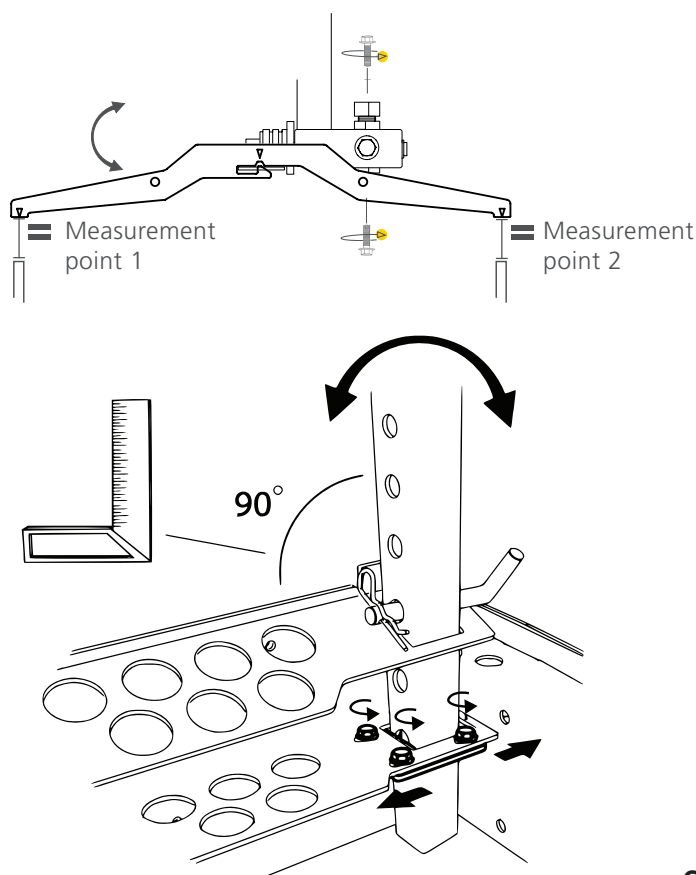

OTHER SETTINGS



Read through all the set-up instructions before starting to set up, then follow the instructions step by step as you work.



The following settings are important for satisfactory operation of the sawmill, but they do not affect one another and so there is no need to implement them in any particular order.

BLADE TENSION

Tension the saw blade by turning the T-handle to the right. Read off the blade tension on the gauge that can be seen inside the band wheel guards. The blade is tightened until the red line is centred on the arrow in the opening for the blade tension spring.

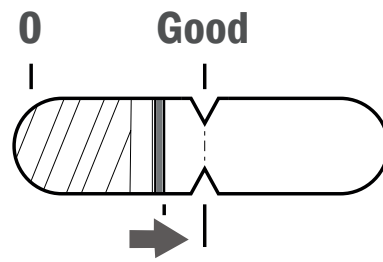

CHAIN LINKAGE

The handle's chain linkage must be extended to ensure that the lifting mechanism works properly. Start by loosening the tensioner's fastening screw, then move the tensioner towards the chain until the chain is tensioned slightly. Then tighten the screw joint.

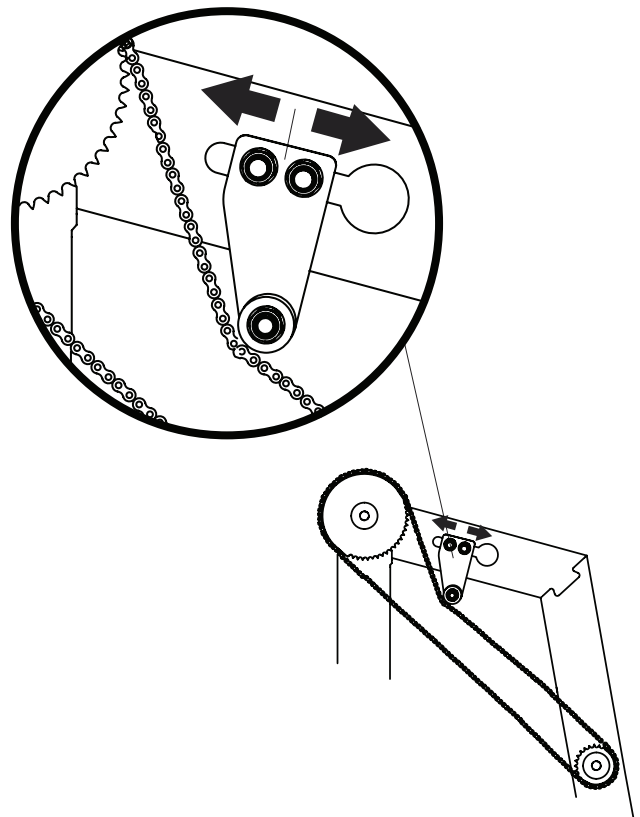

LOG SUPPORT

It is important for the relationship between the log bed and the log support to be perpendicular to ensure the proper functioning of the sawmill. This is adjusted by turning the adjustment handle in the lower part of the log support. Check the perpendicularity using a set square.

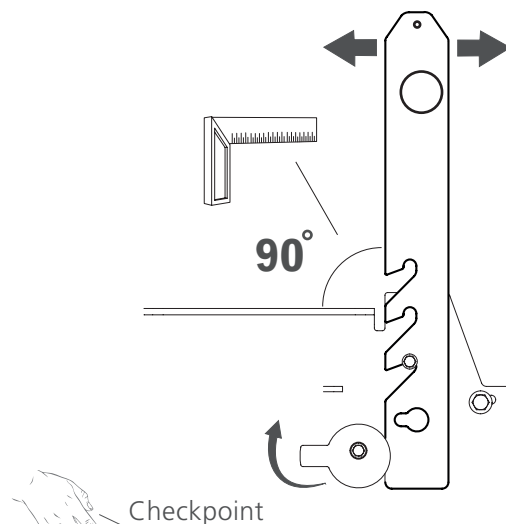

DRIVE BELT TENSION

The drive belt must be tensioned correctly to prevent it wearing on the pulley. The tensioning wheel can rotate around its lower attachment. Tension the belt until the value stated below is reached at the checkpoint.

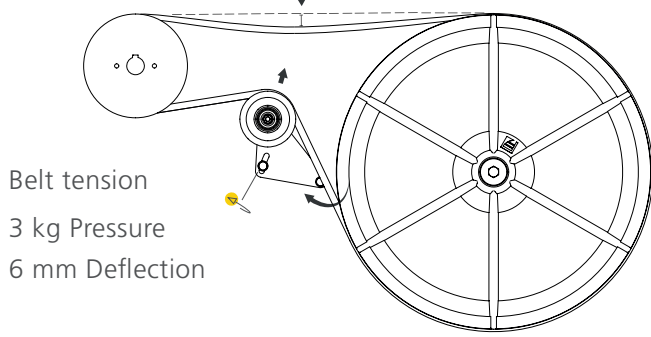

WATER RESERVOIR

The sawmill water reservoir needs to be filled before use. This is done in the tank opening on the back of the saw carriage. The tank volume is 25 litres.

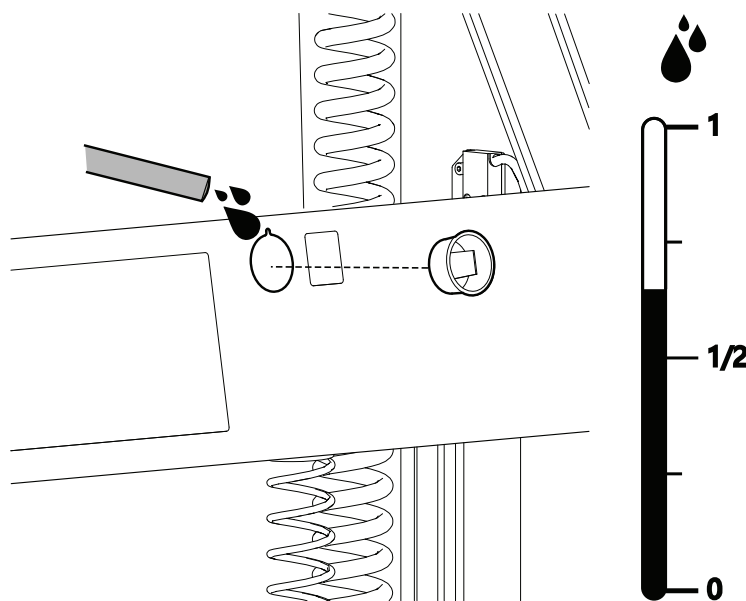

ENGINE INSPECTION BEFORE STARTING

The engine must be filled with oil and refuelled before starting the sawmill for the first time. Place the saw head in the bottom position to make this job easier. Detailed information about the engine can be found in the engine's user manual, which is supplied.

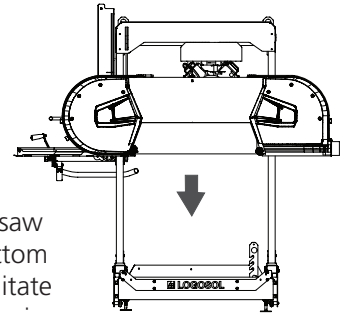

TIP:

Work with the saw head in the bottom position to facilitate access to the engine.

BLADE GUIDES

The blade guides clamp the blade down by 3 mm compared to the wheels.

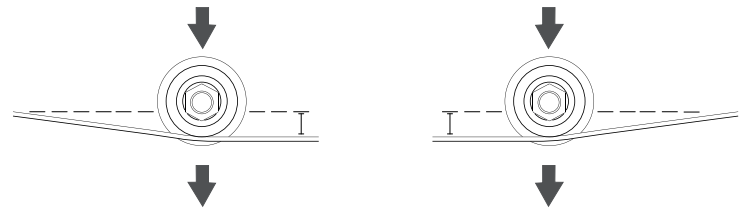

The guides can adjust the blade angle in the sawing direction by adjusting the upper and lower adjusting screws. The guides must be adjusted so that they are parallel to the trailing edge of the blade. This is done by adjusting the outer and inner adjusting screws. It is important for the blade guide roller to run parallel to the blade. Be thorough when setting this feature.

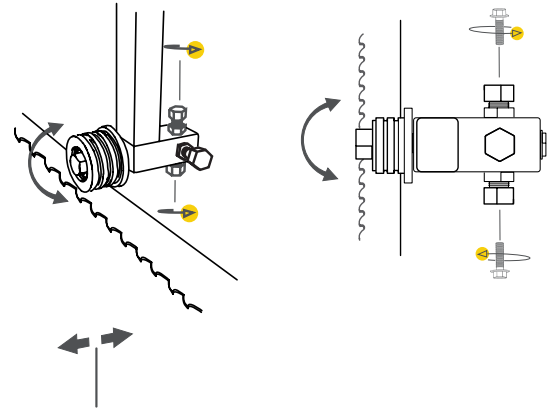

The guides can be adjusted in and out by pulling the shaft after releasing the adjusting screws. The trailing edge of the blade should be about 3 to 5 mm from the flange of the blade guide roller.

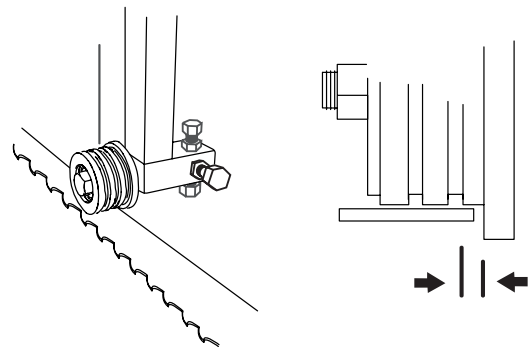

CONTROL BEARINGS

Adjust the control bearing by loosening the nuts and moving them outwards.

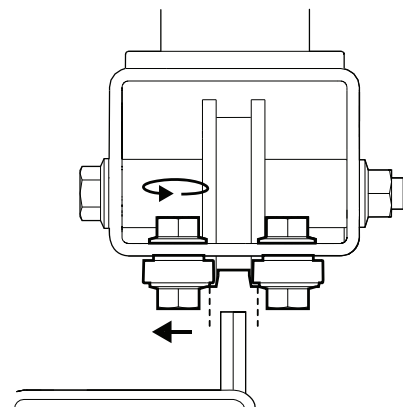

FIRST START-UP

CALIBRATION

The saw blade height position value must be calibrated at the first start-up. The computer networks will show a value in the display at start-up. Measure the distance between the saw blade, on a downward-set tooth and a log bed.

Hold down the calibration button until the value shown in the display disappears, then enter the measured value. Conclude the operation by pressing the enter button.

Check the calibration by moving the saw head 200 mm and measuring to confirm actual saw head movement is 200 mm. If the measurements do not correspond, repeat with a 500 mm movement. Check by measuring from the saw blade to the log bed.

If the measurements still do not agree, try recalibrating.

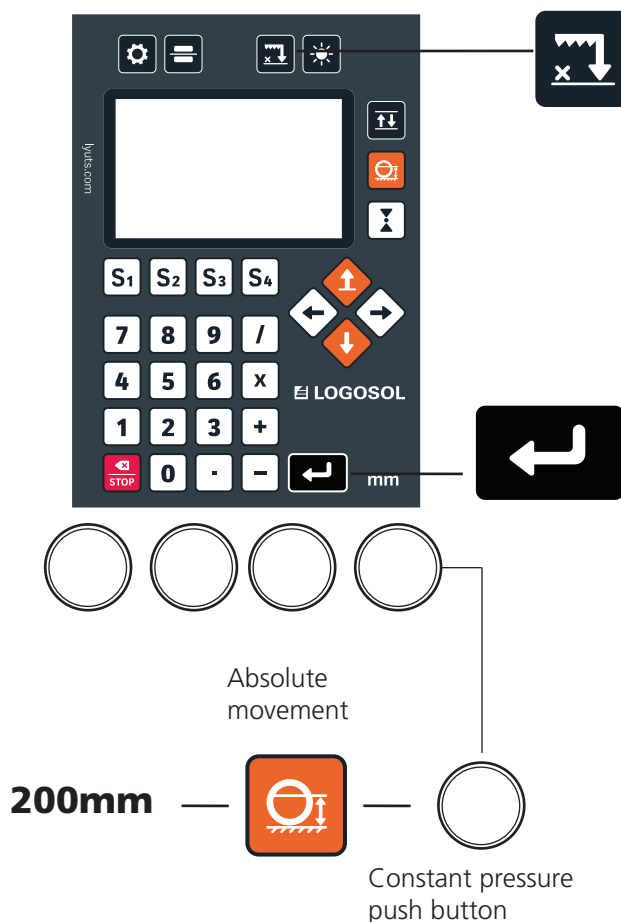
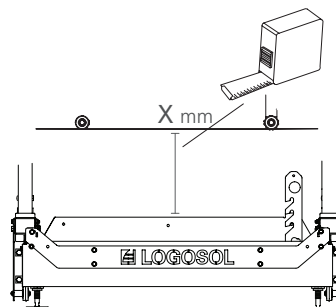

CHECK BEFORE OPERATION

Check that the limit switches are working. Proceed as follows: Run the saw head until the lower switch trips; proceed slowly at the end before impact. Then repeat the operation with the upper switch.

Listen for abnormal noises and make sure the chain is aligned between the upper and lower sprockets.

Make sure there is no physical contact before the limit switches are triggered.

STARTING AND STOPPING

The Pro Set and the Pro Feed are two units used to control the sawmill. The Pro Set handles the vertical movement of the saw head and allows you to set the thickness of the board. The Pro Feed handles the movement of the carriage and the cutting speed.

You can find a more indepth description of how to use the Pro set and Pro feed in the **Pro Set Computer Networks Manual** and **Pro Feed Manual** on the Logosol website.

How To Start

1. Turn the switch on the electrical cabinet to the "ON" position (electric motor).
Turn the switch on the battery box to the "ON" position (petrol motor).
2. Adjust the height of the saw head.
3. Press and hold the constant contact control.
4. Start the motors.
5. Adjust the speed of the saw blade.
6. Move the saw head and carriage forward to start sawing.

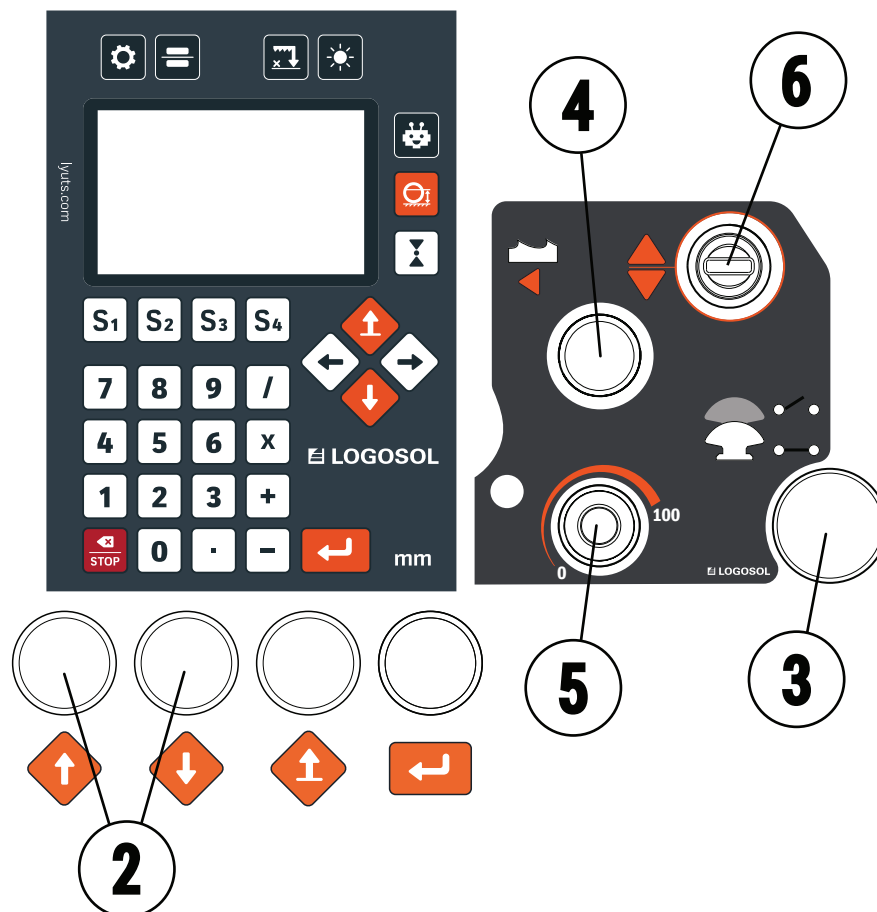

How To Stop

1. The bandsaw blade will slow down and stop when you release the constant contact control.
2. Turn the switch on the electrical cabinet to the "OFF" position.

SAWMILL FEATURES

LOG CLAMP

The sawmill comes with two log clamps so that the log can be secured when sawing. The log clamp feature is eccentric.

Start by adjusting the eccentric plate so that it rests against the log that is to be clamped. This is done by rotating the plate clockwise. Continue tensioning by turning the handle clockwise as shown. The actions are performed in reverse order in order to release the tension. The plate and handle are then turned anticlockwise.

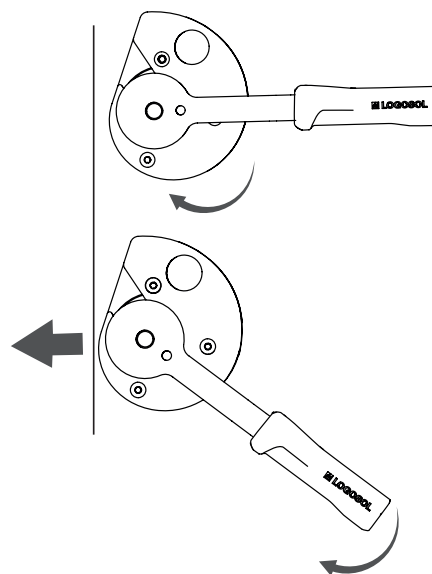







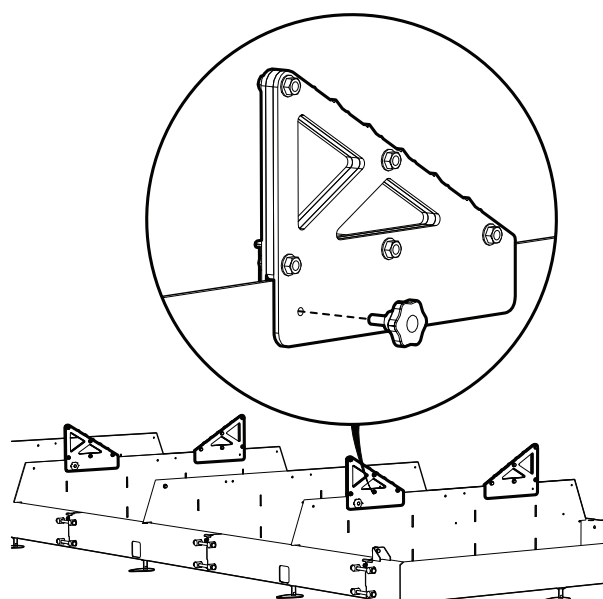

LOG WEDGE

The sawmill comes with four log wedges which help prevent bigger logs from rolling off the sawmill. Adjusting the distance between the wedges allows different size logs to be used.

Here's how to use them: Attach two wedges to crossbunk 2 and 4 counted from the saw head, on the opposite side of your log table. Roll the log from the log table onto the saw mill and position the last two wedges on the other side of the log. You can hit the wedge with a mallet to secure it further under the log before tightening the wheels.



USAGE

-  **WARNING!** Cutting tools: Always stand behind the saw carriage and keep both hands on the handles when operating the machine. Never stand in front of the saw carriage or bandsaw blade. Never pull the saw carriage through a kerf.
 -  **WARNING!** Risk of entrapment and rotating parts: Even slight pressure on the saw head release mechanism can cause the saw head to drop in an uncontrolled manner and the crank to start rotating at speed, which may result in injury.
 -  **WARNING!** Never modify this machine so that it no longer conforms to the original configuration. Do not use the machine if it has been modified. Never use any accessories apart from those that are recommended in this user manual.
 -  **WARNING!** A broken bandsaw blade can eject bandsaw blade fragments at high speed via the chip ejector.
 -  Make sure there is no one on the chip ejection side of the band sawmill while it is working. The risk of bandsaw blade breakage increases if it has not been properly fitted or maintained.
 -  The bandsaw blades and plastic sawmill parts are resistant to temperatures down to -25 °C. Do not use the band sawmill in temperatures below -25 °C.
 -  Make sure that the machine has been properly assembled and maintained in line with the enclosed assembly instructions as well as these instructions.
 -  Never work alone. Always make sure there is another adult within earshot in case you need to call for help.
 -  Do not stand between the log pile and the band sawmill. Always stand to the side of the log pile when handling the logs. Never stand in any location where a log may fall on you.
 -  **WARNING!** Risk of fragments flying off dirty logs.
 -  Always inspect the logs so that there are no objects wedged in the bark before sawing.
- Hazard area:**
-  The minimum safe distances around the band sawmill are shown in Figure 1. Please note that the safe distance on the left side of the band sawmill is 15 m, as there is a risk of saw blade parts being ejected through the chip ejector if the saw blade breaks. The extent of the hazard area on the other sides is 5 m. [Figure 1]
 -  **WARNING!** Keep hands, arms, legs and other body parts well away from the bandsaw blade, cables and other moving parts.
 -  **WARNING!** Risk of collision with the saw carriage.
 -  Always use the parking lock when working with the saw carriage.
 -  **WARNING!** Risk of tripping on rail and crossbars.
 -  Never take a short cut over the rail. Suspend electrical cables so that they are not damaged and do not present a trip hazard.
 -  **WARNING!** Never run the combustion engine in enclosed spaces. Ensure good ventilation. The exhaust gases contain harmful substances that are potentially fatal.
 -  **WARNING!** Risk of entrapment between the sawmill and the log during loading.
 -  The log pile must always be secured by placing a reliable retaining strap around the logs, for example (see Operating instructions).
 -  Never climb onto the rail or the log bed crossbars.

USAGE

Hard knots may cause deviations in the outcome of the sawing.

BEFORE EACH USE:

Check that

- the operator is wearing the prescribed personal protective equipment
- the maintenance prescribed has been carried out
- the bandsaw blade is stationary while the engine is idling
- the machine has been erected so that it is stable and the rail is supported along its entire length
- the anti-tip wheels and rail end stops on the saw carriage are in place
- all components on the band sawmill are secure and serviceable
- all the safety equipment on the machine is in place and in proper working order
- the bandsaw blade is properly installed and runs freely in the right direction.

Before each kerf:

Check that

- there are no other persons or pets within the danger zone of the machine
- there are no obstacles at the work site that could cause a trip hazard or be a nuisance
- the bandsaw blade runs clear of the log supports and log clamp
- the rail is clear of debris, dirt, etc.

- the workpiece is secured in place
- the adjustable saw blade guard is set correctly to accommodate the maximum width of the workpiece.

When in use:

! WARNING! Risk of burn injuries. The engine and its silencer become very hot during operation, and remain hot for a while after the engine has been shut down. This also applies when the engine is idling.

! WARNING! Fire hazard. Petrol and petrol vapours are highly flammable. Bear in mind the fire, explosion and inhalation hazards involved.

! The engine must have been shut down and allowed to cool for 10 min before fuel is added.

Always shut down the combustion engine when leaving the operator station, even you are only away for a few moments to deal with sawn timber or carry out maintenance.

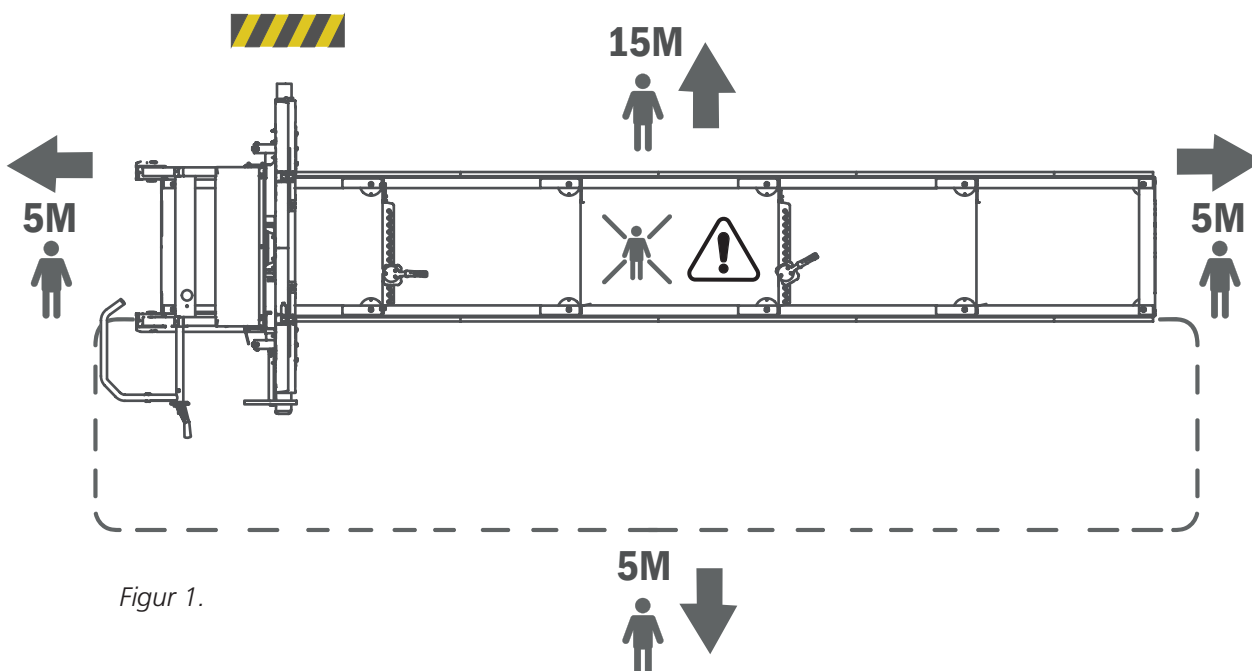

Figur 1.

USAGE

STORAGE

The bandsaw blade must be removed from the machine and stored out of reach of children and other persons, even if the machine will not be used for just a short time.

When stored for longer periods the following applies:

- empty the fuel tank and coolant reservoir,
- remove the bandsaw blade from the machine,
- close the fuel valve,
- lock the saw carriage in position.

Store the band sawmill in a place that is not accessible to children or other persons, preferably in a locked room.

- ! Blade tension must be released at the end of each completed shift to reduce wear on the bandsaw blades.

MAINTENANCE

- ! **WARNING!** Risk of serious injury.

- ! Turn the ignition switch to OFF and close the fuel valve before servicing or performing maintenance on the machine.

- ! **WARNING!** Risk of burn injuries. The engine and its silencer become very hot during operation, and remain hot after the engine has been stopped.

- ! Allow the engine and silencer to cool down before servicing or performing maintenance on the machine.

CHIP COLLECTION

The sawmill can be run without chip extraction if it is used outdoors.

- ! Make sure that the sawdust collecting at the machine is removed at regular intervals using a spade, for example. A capacity of at least 800m³/h is required if chip extraction is connected.

MOVING THE BAND SAWMILL

- ! **WARNING!** Risk of entrapment.

- ! When lifting and moving machine parts, keep persons and animals outside the 5 m danger zone around the machine. Secure the load during transport.

- ! The saw carriage and rail component must not be lifted or transported while assembled, but must be transported separately.

Lifting the saw carriage: Remove the anti-tip wheels of the saw carriage, one on either side, and then use safe lifting equipment to lift the saw carriage using the lifting eyes right at the top of it. Weight, see Technical data.

Lifting of rail component: Use pallet forks or a fork lift to lift the rail from below. Place a protective layer of wood material on the forks before lifting. Make sure that the rail component is well balanced and secure the load to the pallet fork before transporting it. Weight, see Technical data.

REFUELLING

- ! **WARNING!** Risk of burn injuries. Petrol is a highly flammable liquid.

- ! Wait until the machine's engine has cooled down before refuelling it. Turn the ignition switch to OFF and close the fuel valve.

Refuelling: refuel the engine with the saw head in its bottom position and the saw carriage in its locked position at either end of the rail. Use a funnel and try your best to avoid spilling fuel.

- ! Extraction hose: Any extraction hose connected to the sawmill must be fitted with a coil that can be earthed.

OPERATING INSTRUCTIONS

LOG PILE

Do not make the log pile more than 1 m high.

Logs that are contaminated with earth, sand or clay significantly reduce the service life of the bandsaw blade and increase the risk of it breaking. Avoid dragging the logs along the ground, and try to keep them as clean as possible

It may also be a good idea to separate out the various types of timber into different log piles.

LOG TABLE

Logs can be loaded from either side of the band sawmill. The log pile must be secured before each sawing operation if it is on the same side as the operator.

Set the log table to the same height as the crossbars on the bandsaw. The log table should end 10 cm from the band sawmill if it is placed on the left side of the band sawmill. If the log table is placed on the operator's side, it should stop about 1 m from the band sawmill and movable ramp boards should be used between the log table and the sawmill. Make sure the log table has large wedges at its trailing edge so that the logs cannot roll off.

 Make sure that the logs nearest to the band sawmill are secured to prevent them rolling towards the band sawmill while it is running. [See Figure 2]

LOADING LOGS

 **WARNING!** Risk of entrapment between the log and the band sawmill.

 Always stand to one side of the log table when handling the logs. [See Figure 3, area A]

 Try not to stand between the log table/log pile and the band sawmill. The log pile must always be secured when you are in area B [see Figure 3].

 The logs must be rolled off the log table. Do not drop them onto the band sawmill.

When loading a log:

1. Place the saw carriage as far back on the rail as possible (its starting position).
2. The log supports must be raised to their top position when loading logs from the operator's side. The log supports must be moved over to the opposite side of the rail (the operator's side) and mounted in their top position when loading logs from the left side of the band sawmill. The log supports are moved back to the left side of the band sawmill when the log is stable on the rail.
3. If the log table comes with a detachable ramp, fit it so that there is no gap between the log table and the band sawmill.
4. Disconnect the locking device for the front logs on the log table.
5. Roll out a log.
6. Secure the logs at the very front of the log pile.
7. Carefully roll the log onto the log supports of the band sawmill. Use a log turner. Centre the log laterally over the crossbars of the log bed.
8. Adjust the log supports so that they support the log but do not come into contact with the saw blade. Lock the log supports in position.
9. Adjust the log clamps so that they are in the middle of the log supports on opposite sides of the log. Adjust the height of the log clamps to lock the log in place. However, ensure that the log clamps cannot come into contact with the bandsaw blade.

OPERATING INSTRUCTIONS

OP:1

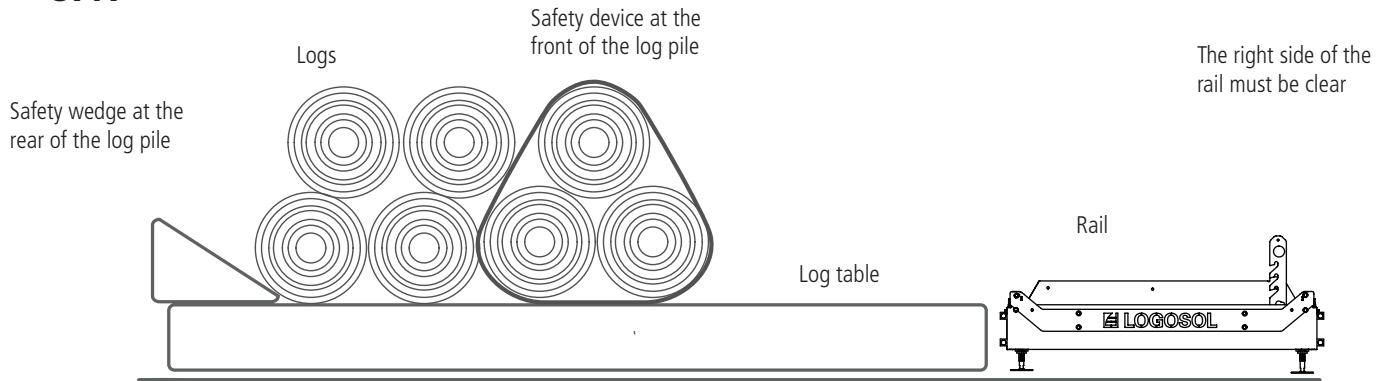

OP:2

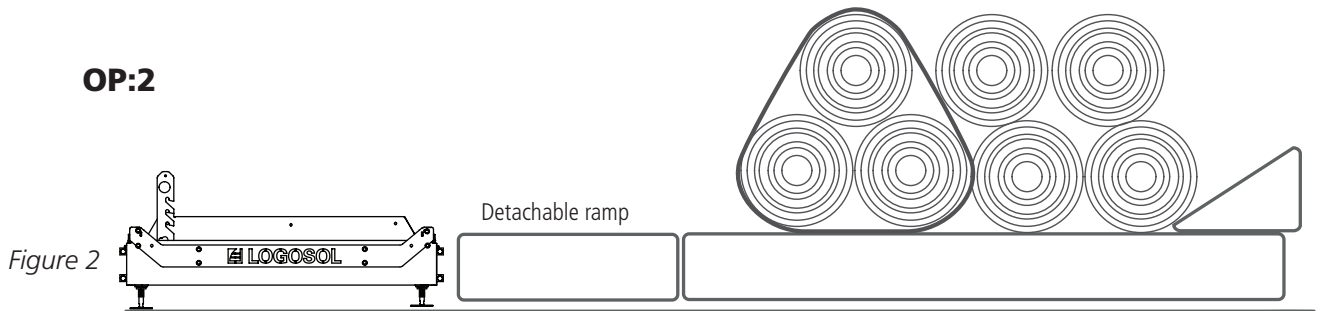

Figure 2

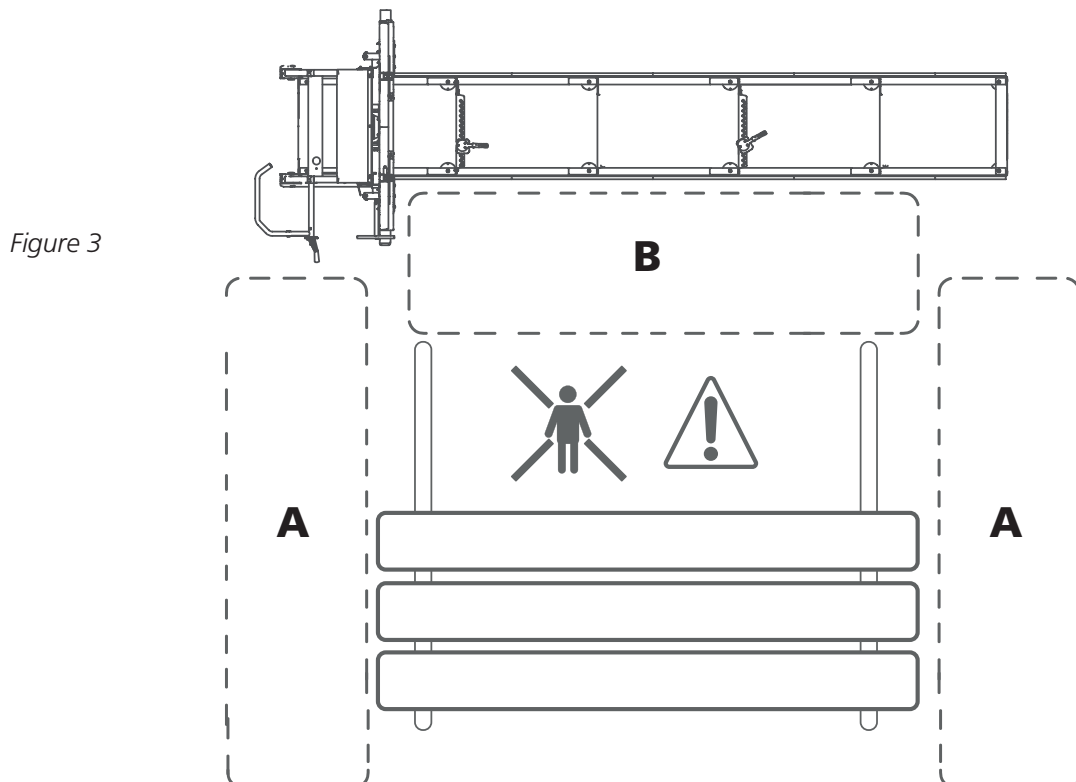

Figure 3

OPERATING INSTRUCTIONS

ADJUSTING THE SAW KERF

The position of the saw head can be adjusted in increments to set the depth of the cut. The B751 PRO band sawmill comes equipped with 1", 1 1/2", 1 3/4" and 2" gauges with saw kerf compensation as standard. The cutting depth is set using the crank on the saw head. Crank down until the mark on the selected gauge is level with the pointer.

SAWING

! **WARNING!** Cutting tools:

! Always stand behind the saw carriage and keep both hands on the handle when operating the machine. Never stand in front of the saw carriage or saw blade. Never pull the saw carriage back through a kerf.

! **WARNING!** Read through and follow all safety instructions described under *Before each saw kerf* in the *Safety instructions* section.

1. Before using the sawmill, perform all the checks described under *Before each use* in the *Safety instructions* section.

2. Raise the log supports by unhooking them and placing them at the preferred height.

! **WARNING!** Risk of entrapment.

! Watch your fingers when the log supports are lowered. Check that the log supports are pushed down properly into the fixed positions.

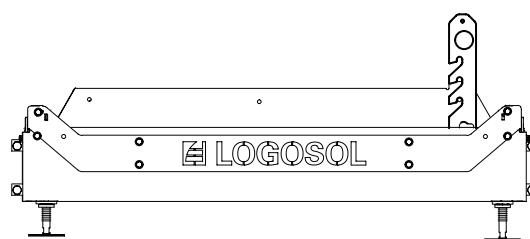

3. Use the log turner accessory when rolling a log onto the log bed. Centre the log on the log bed and roll it towards the log supports. Check the position of the log on the log bed. To ensure the log is cut fully in half, the end must not lie beyond the last crossbar.

4. Rotate the log into a position that gives the best sawing yield.

5. If the log clearly tapers from one end to the other, it is necessary to compensate for this in order to achieve the best possible results. You should always try to saw parallel to the centre line of the log. Place a spacer between the crossbar of the log bed and the narrow end of the log.

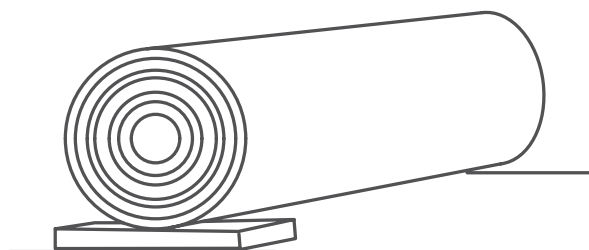

Using a spacer.

OPERATING INSTRUCTIONS

6. Secure the log using the log clamps. Adjust the height of the log clamps, but do not position them so high that the saw blade may come into contact with them.

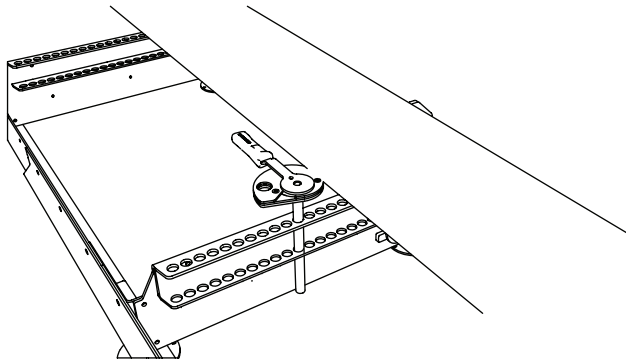

Log clamps. Use of two log clamps is recommended.

7. Set the height of the saw head for the first kerf using the kerf depth crank. Turning the crank clockwise raises the saw head, and turning it anticlockwise lowers it.

8. Check that the saw blade runs clear of the log supports and log clamps.

9. Set the adjustable saw blade guard to allow for the widest part of the log.

10. Open the saw blade flushing valve so that water drips onto the blade guide roller/saw blade.

11. Before each saw kerf, perform all checks referred to under *Before each saw kerf* in the *Safety instructions* section.

12. Stand behind the push handle of the saw carriage, then start the combustion engine. Open the throttle by squeezing the dead man's switch all the way in. This will increase the speed of the combustion engine to its operating range, and the band wheels/saw blade will start to move.

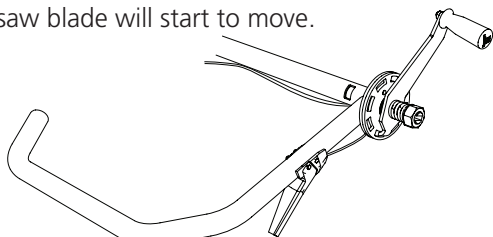

Push handle with dead man's switch.

13. Placing both hands on the push handle, carefully push the saw carriage forward until the saw blade starts to cut into the log. The feed rate can be increased once the entire bandsaw blade is engaged in the log. Keep adjusting the feed rate to ensure the kerf is straight and smooth. Reduce the feed rate when cutting through knots in the log, and select a lower feed rate when sawing coarser logs and harder timber varieties. Also reduce the feed rate as you approach the end of the log.

14. As soon as you have sawn through the log, release the dead man's switch and stand still until the saw blade has come to a complete stop. Tip: The blade will stop more quickly if you release the throttle just before the blade cuts through the log.

15. Remove the sawn section from the log.

16. Raise the saw head slightly and return the saw carriage back to its starting position by hand.

17. Set the height of the next kerf. Use the crank and read off the gauges.

18. Turn the log through 180° so that the freshly sawn surface is lying against the log bed.

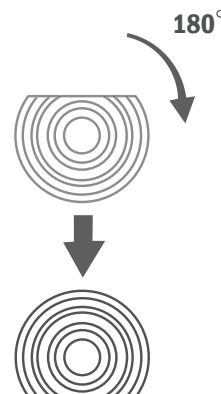

Turn the log through 180° so that the freshly sawn side faces towards the log bed.

Lower the log supports and log clamps so that they cannot come into contact with the saw blade, then clamp the log in position. Saw until you achieve the preferred block width.

OPERATING INSTRUCTIONS

Turn the log through 90° so that one of the freshly sawn sides rests against the log supports, then clamp the log in position. Now you can make the third kerf and obtain finished boards. It may be necessary to compensate for the taper of the log in this situation. Lower the saw supports as you go and saw up the block with the bark facing down.

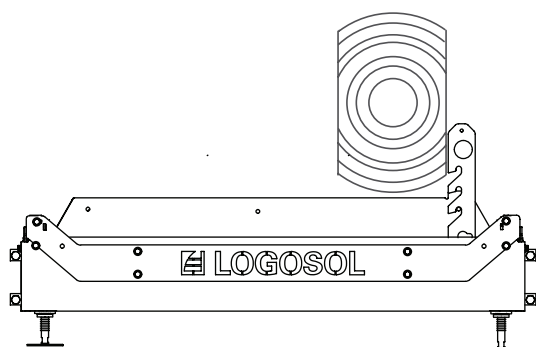

Turn the log through 90° so that one of the freshly sawn sides rests against the log supports, then clamp the log in position.

19. When the log has been turned for the last time in order to saw the last few boards, it is necessary to work out where to start so that everything lines up at the end. It is possible to check this by lowering the saw blade so that it rests against the log. It is then possible to use the absolute gauge to read off how much timber is left under the saw blade. Set the saw head to the preferred height.

TIP: The easiest way to go about it is to hold off on turning the block until there is only enough material left for a 2". Counting is then unnecessary.

HANDLING OF SAWN TIMBER

When sawing boards from the block, you can either lift them off the block straight away or leave them where they are and saw a number of planks before handling the timber.

When then lifting the planks off the rail, take care to ensure that the saw head is locked to one of the ends of the rail. Then move the sawn timber to a stacking area. Place straw between the layers of planks to facilitate drying.

MAINTENANCE

MAINTENANCE

The periodic maintenance on the machine that is expected to be performed by the operator is described in this section. Be sure to follow the specified maintenance intervals, as this is the basis for good function of the sawmill.



WARNING! Risk of serious injury:



Turn the ignition switch to OFF and close the fuel valve before servicing or performing maintenance on the machine.



WARNING! Cuts:



Coiled bandsaw blades may unexpectedly burst open with considerable force. Handle coiled bandsaw blades with great care.



WARNING! Fire risk:



Do not smoke or carry out any work (welding, grinding, etc.) on the band sawmill that could cause sparks that may potentially cause ignition in the vicinity of fuel or combustible materials.



Immediately clear up any fuel spilt on the machine while refuelling it. Change your clothes immediately if you get fuel on them.



Never run the engine if there is a fuel or oil leak. Always turn the engine off before refuelling.

MAINTENANCE

HANDLING SAW BLADES

 **WARNING!** Cutting tools: Incorrect handling of bandsaw blades may result in potentially fatal injuries. Saw blades are extremely sharp.

 **WARNING!** Risk of sustaining cuts.

 **When handling saw blades:**

- always wear protective leather gloves (class 1)
- always wear close-fitting protective eyewear or a visor
- wear protective footwear with saw protection, steel toe-caps and non-slip soles
- always wear full-length protective trousers
- keep persons and animals at a safe distance, at least 5 m

REPLACING BANDSAW BLADES

It is important to replace the saw blades regularly for maximum cutting performance. Fifteen to thirty logs can normally be sawn before replacing the blade, but this is very much dependent on how contaminated the bark is. Using blunt saw blades will result in crooked or incomplete kerfs, reduced saw blade service life and greater risk of saw blade breakage. Always wear protective leather gloves when handling saw blades.

To remove the saw blade:

1. Release the blade tension by turning the T-handle counter-clockwise.
2. Open the covers over the band wheels.
3. Remove the saw blade from the band wheels.

Fitting a new saw blade:

1. Position the saw blade under the blade guides first and then round the band wheels. Make sure that the saw teeth point towards you
2. Rotate the bandsaw blade by hand in the kerf direction and check that the tracking of the bandsaw blade has not changed. See setting the longitudinal blade position on page 25.
3. Replace the band wheel guards.
4. Close the hatch.

LUBRICATION POINTS

It is important to lubricate the components of the sawmill as described below in order to ensure your sawmill remains in good condition for many years, and to ensure problem-free ownership. Lubrication must be carried out:

- Immediately after assembly and before starting to use the sawmill.
- Every 50 hours of operation, but at least once a year.

The lubricants to be used on the sawmill are:

- | | |
|-----------------------------|--------------------|
| • Superflo | SKU: 9999-000-5115 |
| • Universal lubricating oil | SKU: 9999-000-5105 |
| • Silicone | SKU: 9999-000-5110 |
| • Grease | ISO-L-XCCIB2 |

Rail pipe sections

Lubricant: Universal lubricating oil

Insert the nozzle of the spray can into all openings and spray the inside of the pipe sections to protect against corrosion.

Top sections of the rail on which the saw carriage travels

Lubricant: Universal lubricating oil

Blade tensioning T-handle

Lubricant: grease or Superflo

Unscrew the T-bar and apply copious amounts of lubricant to the threaded rod.

Saw head lifting chains and chain transmission

Lubricant: Superflo

Lubricate the whole chain.

Lifting winch shaft

Lubricant: Superflo

Grease both sides from the outside.

The petrol engine's throttle cable and handle

Lubricant: Superflo

Lubricate the joints of the handle and spray oil into the cable from the ends. If the cable is hard to move, remove the cable from its housing, lubricate it along its entire length and spray oil into the cable housing.

Saw carriage main post

Lubricant: Silicone

Lubricate the sliding surfaces of the saw head and the plastic guides.

MAINTENANCE

CLEANING THE BAND SAWMILL

Clean the band sawmill after every shift. Brush out any wood chips or sawdust inside the band wheel guard and on and around the rail. Wipe painted surfaces and plastic parts with silicone spray (SKU: 9999-000-5110). Lubricate moving parts with Superflo (SKU: 9999-000-5115).

WATER RESERVOIR

Drain the water from the reservoir and pipes if the temperature falls below zero. Washer fluid may be used as a lubricant at sub-zero temperatures. Never use glycol or flammable liquids as coolant.

HORIZONTAL SAW BLADE ALIGNMENT

Check before every shift that the saw blade is parallel to the log bed.

COMBUSTION ENGINE

Check the oil level in the engine before every shift. Follow the maintenance schedule in the instruction manual for the engine.

SAW HEAD LIFTING CHAINS

Check the saw head lifting chains for damage. Replace the chains if necessary.

CHECKING SAFETY FEATURES

Before every shift, check that the following safety features are working: Check that the throttle handle returns so that the engine idles when the handle is released. If it does not, lubricate the throttle cable with Superflo (SKU: 9999-000-5115). Check that the switch in the saw guard hinge is working. Check by opening the covers with the engine off and listening for the switch to trip.

RAIL FLATNESS

Check the balance of the rail before every shift, especially in winter when ground frost may affect the surface.

BAND WHEEL BELTS

Check the condition of the drive wheel belt and belt of the undriven wheel at regular intervals. Replace any worn or damaged parts. Check the drive belt tension at regular intervals, and adjust if necessary.

BLADE GUIDES

Check the condition of the blade guide rollers at regular intervals and ensure that the distance between the blade guide roller flange and the bandsaw blade is within 3 to 5 mm. Replace worn or damaged blade guides.

BAND WHEEL GUARDS

Clean the inside of the band wheel guards and the saw blade to remove any sawdust build-up once an hour when working, or when replacing saw blades.

BANDSAW BLADE

Replace the bandsaw blade with a new, sharp one after about every two hours of efficient sawing.

TROUBLESHOOTING SCHEDULE

PROBLEM/SYMPTOM	PROBABLE CAUSE	ACTION
The blade quickly loses its sharpness	<ul style="list-style-type: none"> • Dirty logs • The saw blade is worn out 	<ul style="list-style-type: none"> • Avoid dragging the logs over the ground • Debark the log where the blade is going to cut • Square the logs before cutting boards, to minimize the cuts into bark • Replace the blade with a new one
Wavy cuts	<ul style="list-style-type: none"> • Dull blade • The feed speed is too high • The feed speed is too low • Sawing through a partly frozen log 	<ul style="list-style-type: none"> • Resharpener the blade • Lower the feed speed • Increase the feed speed • Let the log fully thaw or fully freeze before sawing it <p>TIP: Do not use a slower sawing speed when the blade is entering the log, but cut into the log end with the same sawing speed you are planning to have for the rest of the cut</p>
The blade dives or rises when sawing	<ul style="list-style-type: none"> • Insufficient blade tension • The feed speed is too high • The blade is damaged • The blade does not track correctly on the band wheels 	<ul style="list-style-type: none"> • Increase the blade tension • Lower the feed speed • Replace the blade with a new one • Install the blade correctly and adjust the tracking
Blade breakage	<ul style="list-style-type: none"> • The blade is worn out • Dull and/or incorrectly installed blade • The blade tension is too tight • The blade guide rollers are not aligned with the band wheels • Worn band wheel belts. This makes the blade running directly on metal 	<ul style="list-style-type: none"> • Replace the blade with a new one • Resharpener the blade • Reduce the blade tension • Adjust the blade guides • Replace the belts on the band wheels with new ones
Uneven board thickness	<ul style="list-style-type: none"> • The log bed flexes due to insufficient support 	<ul style="list-style-type: none"> • Support the rails/log bed as outlined in the instructions in this manual
The blade does not track correctly and slips off the band wheels	<ul style="list-style-type: none"> • The band wheels are incorrectly adjusted • Worn band wheel belts 	<ul style="list-style-type: none"> • Adjust the band wheels as outlined in the instructions in this manual • Replace the belts with new ones

PROBLEM/SYMPTOM	PROBABLE CAUSE	ACTION
The blade does not cut	<ul style="list-style-type: none"> The blade is installed backwards 	<ul style="list-style-type: none"> Remove the blade and turn the blade inside out and reinstall it When the sawmill is powered by an electric motor, check that the motor is running in the correct direction. If not: Reverse the phase of the electric motor.
The blade does not slacken after releasing the blade tension with the T-handle	<ul style="list-style-type: none"> The blade tension assembly is sticking 	<ul style="list-style-type: none"> Push the T-handle inwards
The sawhead is stiff when raised or lowered	<ul style="list-style-type: none"> The vertical guides are too tight The sawhead lifting winch drum is dry 	<ul style="list-style-type: none"> Lubricate with silicone and, if necessary, loosen them slightly Lubricate with Superflo
The sawhead is rattling when going down	<ul style="list-style-type: none"> The rails are not level and cause the saw bogie to twist 	<ul style="list-style-type: none"> Level the rails as outlined in the instructions in this manual.
The blade overheats during operation	<ul style="list-style-type: none"> The water tank is empty The water valve is closed 	<ul style="list-style-type: none"> Refill with water Open the water valve
The engine does not start	<ul style="list-style-type: none"> The ignition key is in the "OFF" position The interlock safety switch on the blade guards is disconnected 	<ul style="list-style-type: none"> Turn the ignition switch to the "ON" position Check the working order of the interlock safety switch
The computer networks do not start	<ul style="list-style-type: none"> Loose contacts. Moisture in the computer networks. Residual current device (RCD) tripped. Fuses blown in the saw box. 	<ul style="list-style-type: none"> Try removing the connectors and then reinstalling them. Disconnect the power and take the box inside, let it dry and blow it out with compressed air. If an RCD trips, contact an electrician for troubleshooting. Replace the fuses in the saw box.
The computer networks is working, but the height adjustment motor does not run.	<ul style="list-style-type: none"> The motor is running hot; motor protection has stripped. 	<ul style="list-style-type: none"> Wait until the motor has cooled and resume operation; the motor must not run hot. If the problem recurs, contact Logosol.
Abnormal noises from the mechanism.	<ul style="list-style-type: none"> Poor lift chain alignment. Insufficient chain tension. Gearbox wear. Worn bearings. Over-tensioned chain. 	<ul style="list-style-type: none"> Check alignment between the lower and upper lift sprockets. Check chain tension. If bearing or gearbox wear is suspected, check for visual wear on the saw head bearings at the secondary shaft and at the gearbox mounting. Run the functions and listen for abnormal noise and feel if heat is building up. If a worn part is discovered, replace it.
The machine runs in the wrong direction	<ul style="list-style-type: none"> Phase reversal in connector. 	<ul style="list-style-type: none"> Switch phases in the machine's 400v socket.



Declaration of Conformity

In accordance with Directive 2006/42/EC, Annex 2A

Logosol AB
Arkivvägen 6
SE-871 53 HÄRNÖSAND

hereby declares that **Logosol B1651**

has been manufactured in conformity with:
the Machinery Directive 2006/42/EC, the EMC Directive
2014/30/EU

and has been manufactured in conformity with the following
harmonised standards:

EN ISO 12100:2010, EN 60204-1:2018,
EN 50370-1:2005, EN 50370-2:2003.

Notified body, 0404, RISE SMP Svensk Maskinprovning AB, Box
7035, SE-750 07 Uppsala, Sweden, has performed EC type
examination according to Directive 2006/42/EC, Article 12(3b).
The EC type examination certificate is numbered: 0404/17/2408

The band sawmill supplied is identical to the band sawmill that
underwent EC type examination.

Härnösand, January 30th, 2026

A handwritten signature in black ink, appearing to read "R. Berglund".

Robert Berglund, CEO

LOGOSOL

Arkivvägen 6, SE-871 53 Härnösand
+46 (0)611-182 85 | info@logosol.com | www.logosol.com