

USER MANUAL

ORIGINAL USER MANUAL.

SKU 0458 395 5401

REV: 8

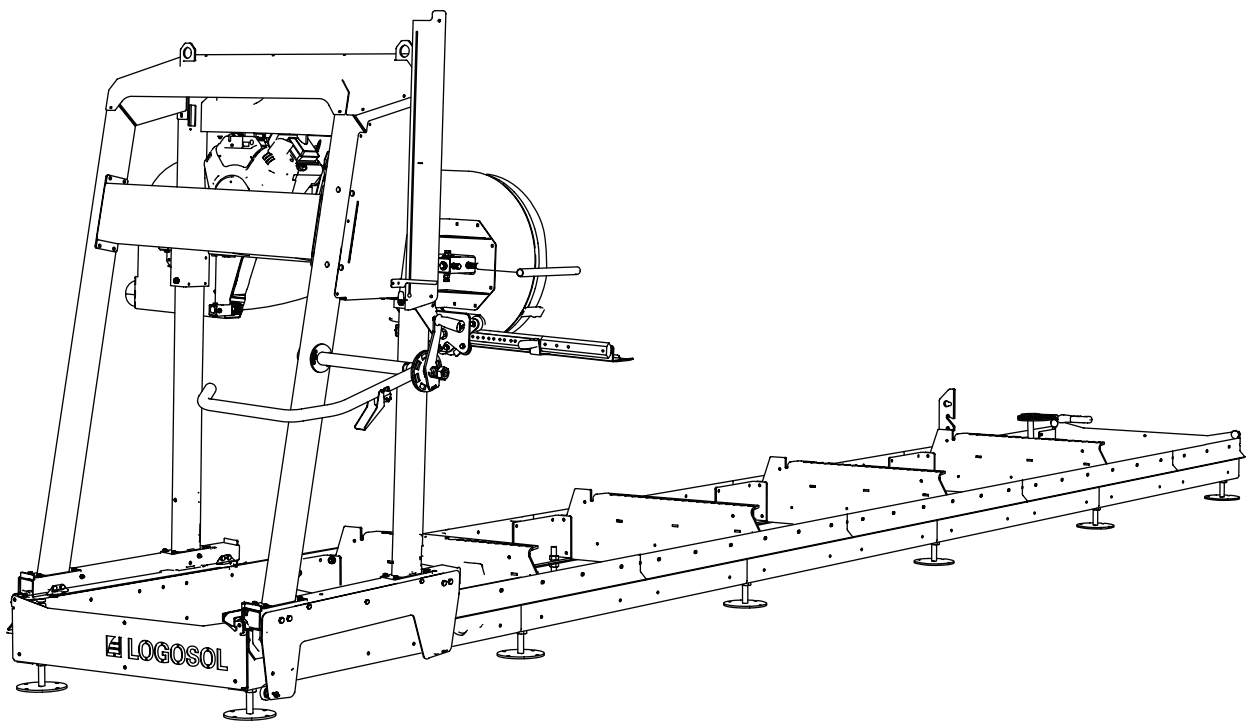

LOGOSOL B751 BAND SAWMILL



Read through the user manual carefully and make sure you understand its contents before using the saw.



This user manual contains important safety instructions.



WARNING! Incorrect use can result in serious or fatal injuries to the operator or others.



THANK YOU FOR CHOOSING A LOGOSOL MACHINE!

We are very pleased that you have demonstrated your confidence in us by purchasing this sawmill and we will do our utmost to meet your expectations.

LOGOSOL has been manufacturing sawmills since 1989, and in that time we have supplied approximately 50,000 machines to satisfied customers the world over.

We are concerned with your safety and ensuring that you achieve the best possible results with your sawmill. We therefore recommend that you take the time to read this user manual carefully before starting your sawing. Remember that the machine itself is only a part of the value of the product. Much of the value is also to be found in the expertise we pass on to you in the user manual. It would be a pity if that was not utilised.

We hope you will be thoroughly satisfied with your new machine.

A handwritten signature in black ink that reads 'Bengt-Olov Byström'.

Bengt-Olov Byström
Founder,
Logosol in Härnösand



LOGOSOL continuously develops its products.
For this reason, we must reserve the right to modify
the configuration and design of our products.
Document: LOGOSOL B751 User manual
SKU user manual SE: SKU 0458 395 5400
Text: Mattias Byström, Robert Berglund, Martin Söderberg
Illustrations: Mattias Byström, Martin Söderberg, Robert Berglund, Anna Fossane
© 2026 LOGOSOL, Härnösand, Sweden

TABLE OF CONTENTS

General information	4
Description of the band sawmill	5
Safety instructions	6
Technical data	8
Component parts	10
Mounting the rail	12
Setting: Rail	20
Final assembly: rail	23
Saw head	25
Final saw head assembly	28
Installation of the motor: see separate instructions	31
Adjustment sequence	32
Other settings	38
Sawmill features	41
Wiring diagram	43
Use	44
Chip collection	46
Start / stop	47
Operating instructions	48
Maintenance	52
Troubleshooting	55
Machine declaration	56

GENERAL INFORMATION

This user manual, the instruction manual for the motor, the band sawmill's assembly instructions, and the instructions for accessories, are to be regarded as constituent parts of the band sawmill. They must also remain with the band sawmill if it is sold on.

Responsibility for correct assembly, commissioning and use of the band sawmill rests with whoever has assembled it and the people who use it.

DESCRIPTION OF THE BAND SAWMILL

B751

Forwards

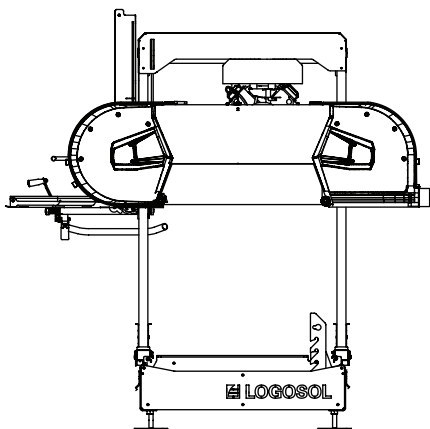

Back

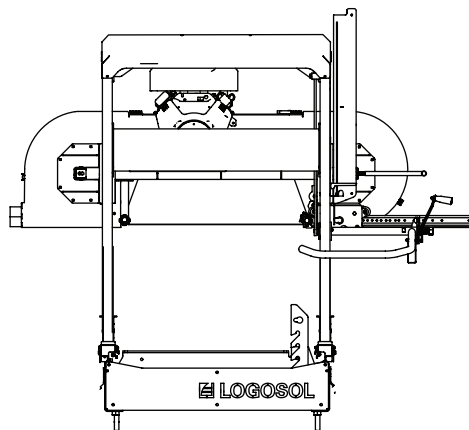

Page

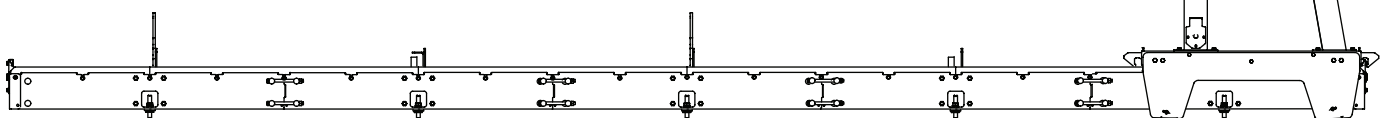
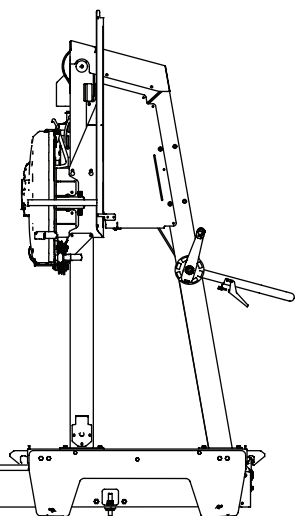

DESCRIPTION OF THE BAND SAWMILL

LOGOSOL B751

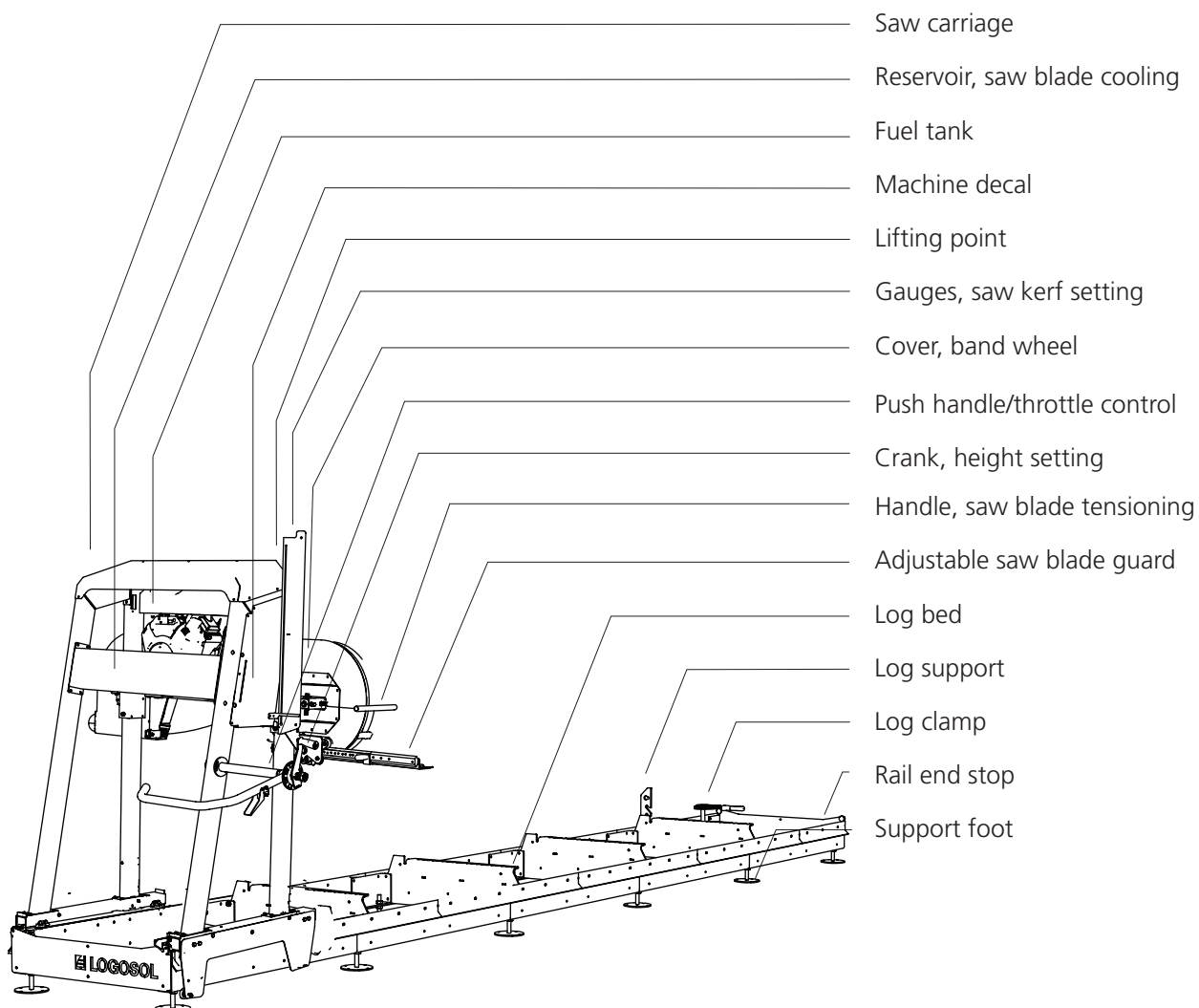

SAFETY INSTRUCTIONS

KEY TO SYMBOLS



WARNING! This symbol means that you have to take particular care. It is always accompanied by information on the specific risk.



ATTENTION. A warning comes after this symbol. Pay particular attention where this symbol appears in the manual text.



For your own safety and that of others, do not use the bandsaw mill or handle bandsaw blades without first reading through and understanding the contents of this user manual in its entirety.



WARNING! Cutting tools: Incorrect use of the machine can lead to life-threatening injuries. Bandsaw blades are extremely sharp and dangerous.



Always wear protective gloves (class 1) when fitting and working with the band sawmill or handling bandsaw blades. Risk of lacerations when handling bandsaw blades and some sheet metal. Bandsaw blades and motor parts can be hot after sawing.



Always wear approved hearing protection when working with the machine. Even brief exposure to high frequency noise can damage your hearing. Always use close-fitting safety goggles when working with the machine or handling bandsaw blades. Under certain circumstances the use of a protective mask may also be advisable. This would primarily apply if you are sawing dry wood or sawing indoors.



Always wear approved protective footwear with saw protection, steel toe-caps and non-slip soles when working with the machine or handling bandsaw blades.



Always wear full-length protective trousers when working with the machine or handling band blades. Never wear loose-fitting clothing, scarves, neck chains, etc. that can get caught in the machine when working. Secure loose hair before working with the Band sawmill.

SAFETY INSTRUCTIONS

THE BAND SAWMILL'S SAFETY EQUIPMENT

 **WARNING!** Never use the machine if the safety equipment is defective..

 Safety equipment must be checked and maintained.

Here is a description of the items of safety equipment on the band sawmill, together with their features.

Interlocking protection over band wheels

One of the hinges on the band wheel guards comes with safety switches. The hatches must be closed before using the machine.

Rail end stops

These mechanical stops prevent the saw carriage rolling off the end of the rail.

OPERATOR

 **WARNING!** Whenever the machine is used, approved personal protective equipment must always be used.

 Persons under the age of 18 may not use the band sawmill or handle bandsaw blades.

 Never use the machine or handle bandsaw blades if you are tired, if you have consumed alcohol or are taking medicine that can impair your sight, judgment or control over your body.

WORK SITE

 **WARNING!** Never operate a band sawmill with a combustion engine in a closed or poorly ventilated area. Doing so can cause death by asphyxiation or carbon monoxide poisoning.

 The use of the band sawmill and the handling of saw blades must be carried out in broad daylight or in adequate work lighting.

 Keep the workplace free of debris, pets, children, obstacles and anything else that may distract the operator.

 Choose an erection site where the supporting ground is tightly compacted and level, with generous space for the band sawmill, log piles and sawn wood. If possible, position the band sawmill so that the sawdust is blown away from the operator station. Set up the band sawmill on a level surface, with at least 5 m of clear, obstacle-free space all around the machine. If the band sawmill is to be set up permanently, we recommend supporting the bandsaw rail on cement slabs or wooden blocks (15 cm x 15 cm) placed under each crossbar.

 Always have an ABC type handheld fire extinguisher (min. 6 kg) readily available at the work site.

 Always have a complete first aid kit to hand at the work site.

TECHNICAL DATA

LOGOSOL B751	
RAIL COMPONENT	
Rail length, standard	5.75 m
Rail length, extension	1140 mm
Track width	800 mm
Overall width	850 mm
Height	230 mm
Weight (5.75 m rail)	195 kg
SAW CARRIAGE	
Length	900 mm
Width	1975 mm
Height	170 cm
Weight	178 kg
Volume, water reservoir	7.5 litres
Feed rate	Manual
CAPACITY	
Max. log diameter	750 mm
Max. sawing width	600 mm
Effective saw length (standard)	4.8 m
BANDSAW BLADE	
Type and size	3843x33 pitch 22 mm
Band wheel diameter	500 mm
Band wheel, rotational speed	1000 v/min
Saw blade, speed	28 m/s
SAW MOTOR(S)/ENGINE	
Electric motor drive	4.5 kW (weight: 30 kg) or 8 kW (weight: 40 kg)
Petrol engine	Briggs & Stratton 13 hp (weight: 30 kg) or 18 hk (weight: 34 kg)
Volume, fuel tank	5 litres
NOISE LEVEL/VIBRATIONS	
Equivalent sound pressure level at ear of operator 1)	88.4 dB(A)
Sound power level (estimated) 2)	109.4 dB(A)
Vibration level in handle 3)	<2.5 m/s ²

1) The typical distribution measurement for equivalent sound pressure level is a standard deviation of 2 dB(A)

2) The typical distribution measurement for sound power level is a standard deviation of 3 dB(A)

3) The typical distribution measurement for vibration level in the handles is 1 m/s²

BOLTS/NUTS

Definition of the fasteners on following pages.

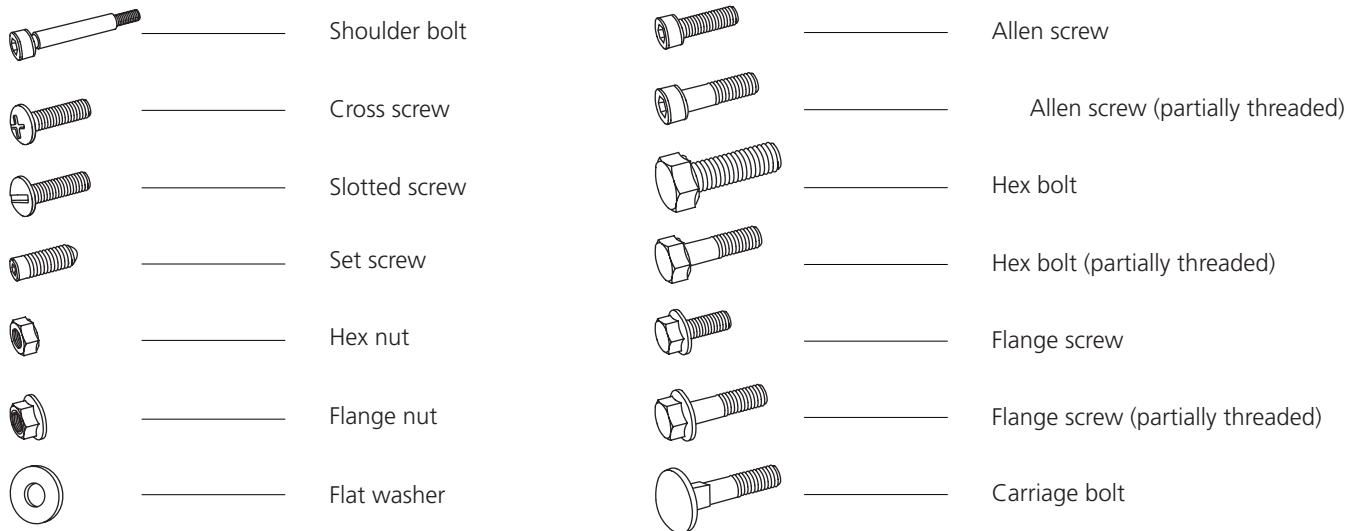

ADDITIONAL SYMBOLS

The following symbols are used in addition to those shown above to describe part design.



DIMENSIONS/LENGTH

The dimensions of the fasteners are printed as a diameter dimension (M) ISO 68-1. This is followed by a length dimensions for bolts/screws; the dimension of a bolt/screw is the part of the bolt/screw that disappears into the material in which it is mounted.

(Diameter) **(Length)**

M8 x 20

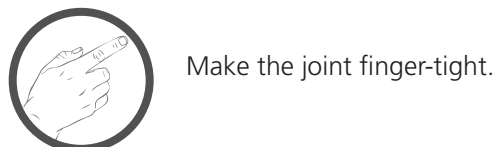
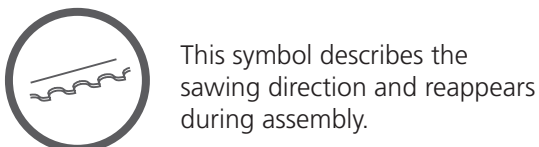
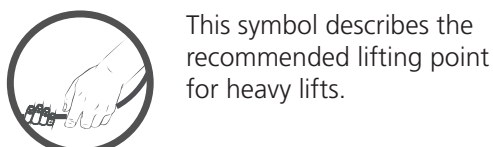
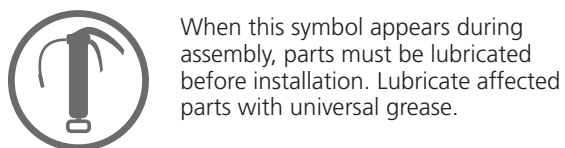

LOGOSOL



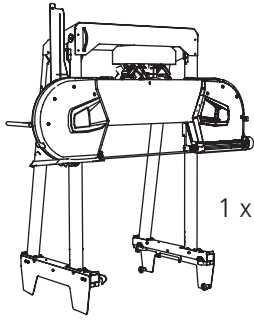

COMPONENT PARTS





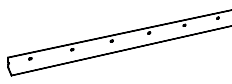
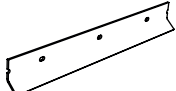
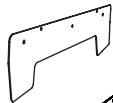
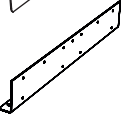

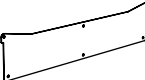
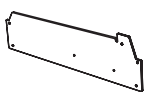
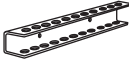
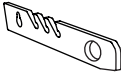



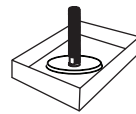

1 x — 8400-000-000

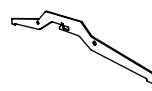

01-00306

-  — 8 x — 03-01959
-  — 4 x — 03-01964
-  — 2 x — 03-01979
-  — 10 x — 03-01957
-  — 2 x — 03-01968
-  — 2 x — 03-01969
-  — 4 x — 03-01970
-  — 2 x — 03-01985
-  — 2 x — 03-01983
-  — 4x — 03-01967
-  — 4 x — 03-01966

-  — 2 x — 8210-001-0020
-  — 1 x — 02-00247
-  — 12 x — 9039-001-0005
-  — 2 x — 03-01880
-  — 1 x — 03-03054
-  — 1 x — 8400-005-0005
-  — 1 x — 8400-005-0010
-  — 1 x — 8400-005-0020
-  — 1 x — 8400-005-0030
-  — 1 x — 8200-005-0200





COMPONENT PARTS



8400-005-0005







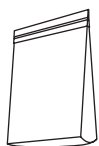

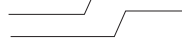

8400-005-0010

		— 100 x —	M8x20	9018-346-0820
		— 110 x —	M8	9214-352-0008







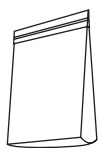

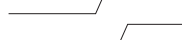

8400-005-0020

		— 6 x —	M8	9291-021-0180
		— 4 x —	M8x25	9018-346-0825
		— 12 x —	M8x12	9018-346-0812
		— 4 x —	M8x30	9018-346-1860







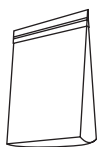











8400-005-0030

		— 4 x —	M6	9291-021-0140
		— 24 x —	M16	9210-260-1600
		— 4 x —	M6x35	9018-346-1380
		— 4 x —	M6	9214-352-0006

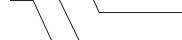

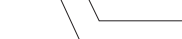
8200-005-0200

		— 6 x —		9291-020-0005
		— 2 x —		03-01464
		— 4 x —		9026-015-0002
		— 2 x —		03-01465
		— 4 x —		9029-011-0001
		— 1 x —		03-01772
		— 1 x —		03-01773
		— 4 x —		03-01982



RAIL ASSEMBLY

Work on a surface that is as flat as possible, as this will make it easier to set the rail.

 **WARNING!** Heavy lifting! Risk of injury.

 Two people are always required to help with heavy lifting.

 **WARNING!** Risk of crushing injury.

 Wear protective gloves and handle the motor carefully when placing it on the motor shelf.



Now it is time to assemble the rail. Follow the assembly steps carefully, and adopt an ergonomically correct posture when working. Work on a surface that is as flat as possible, as this will make it easier to set the rail.



Read through all the assembly instructions before starting assembly, then follow the instructions step by step as you work.



Numbering for installation sequence



Well done!

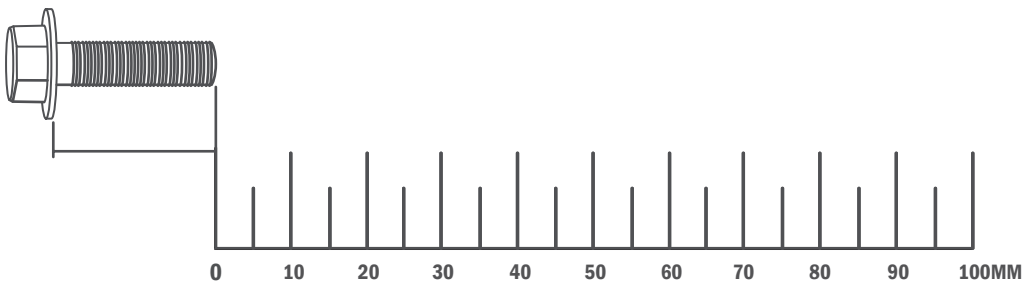

1

Assemble the bed fittings with the log bed. Note that it is important to install the fittings as illustrated.

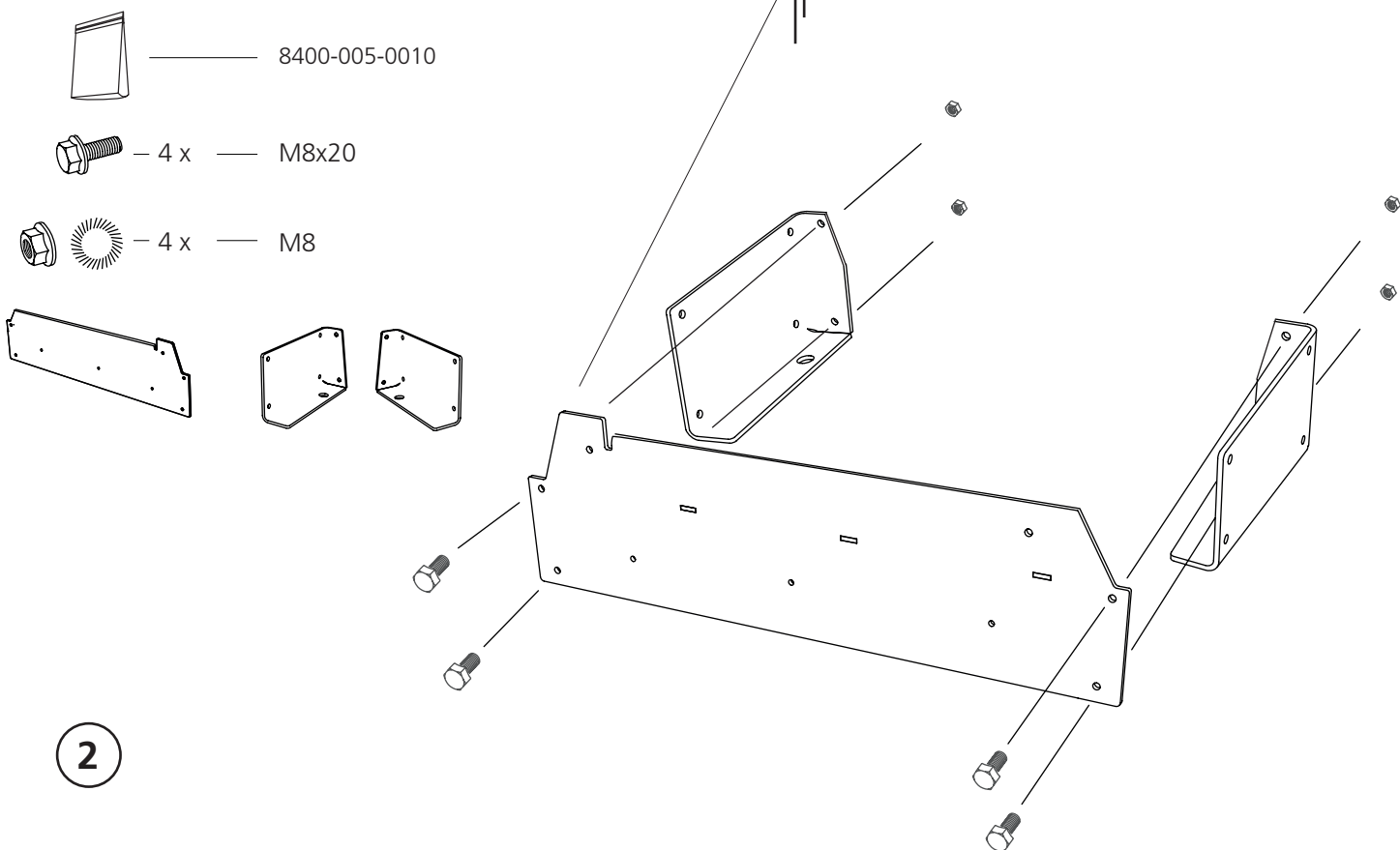

2

Repeat the installation procedure on the other log beds.

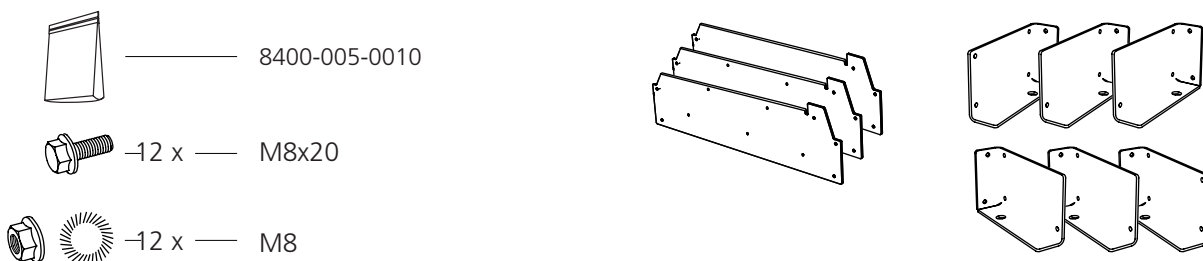

3

Assemble the rail sections with the log bed. Note that these must only be fitted in the lower hole and tightened loosely.

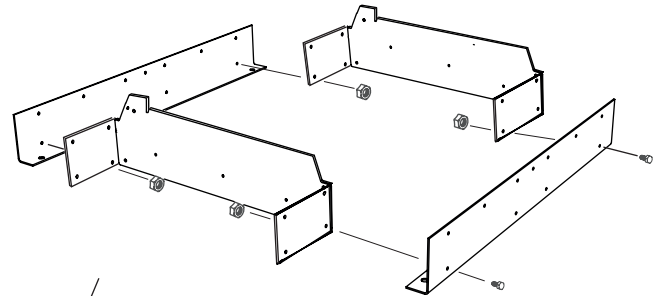
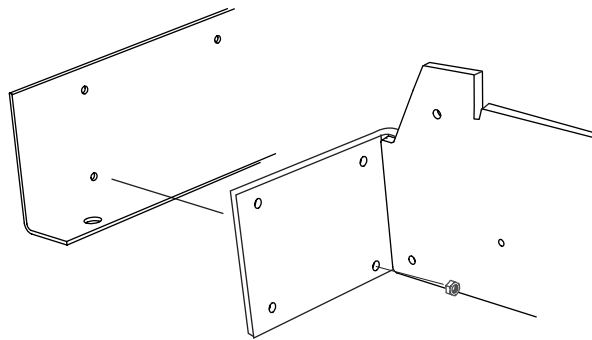
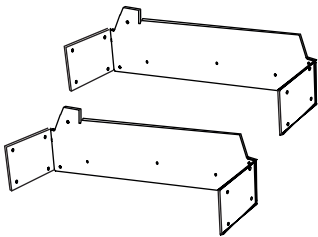
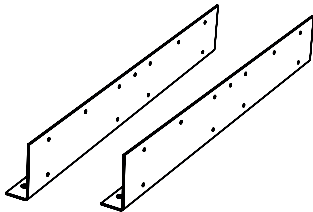
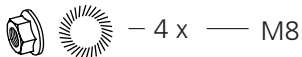
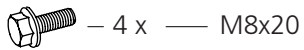
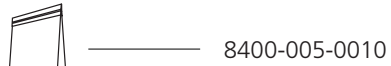

4

Assemble the rail sections with the log bed. Note that these must only be fitted in the lower hole and tightened loosely.

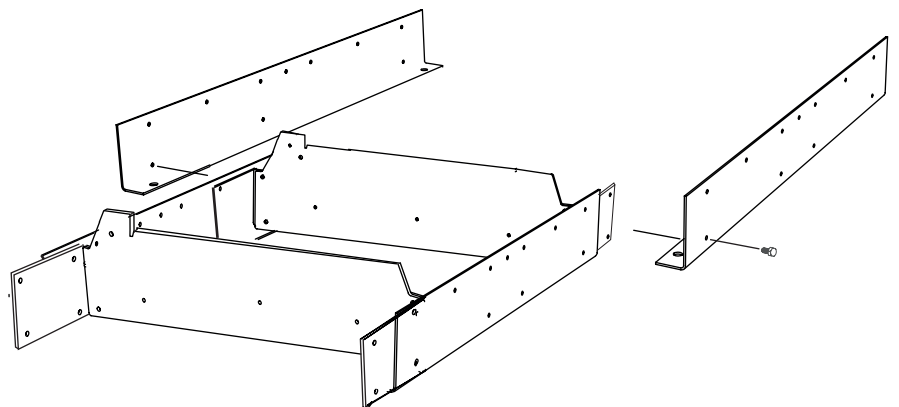
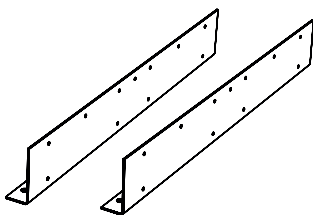
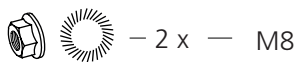
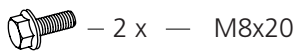
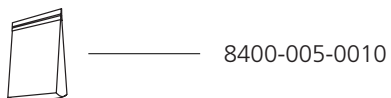

5

Assemble the rail sections with the log bed. Note that these must only be fitted in the lower hole and tightened loosely.

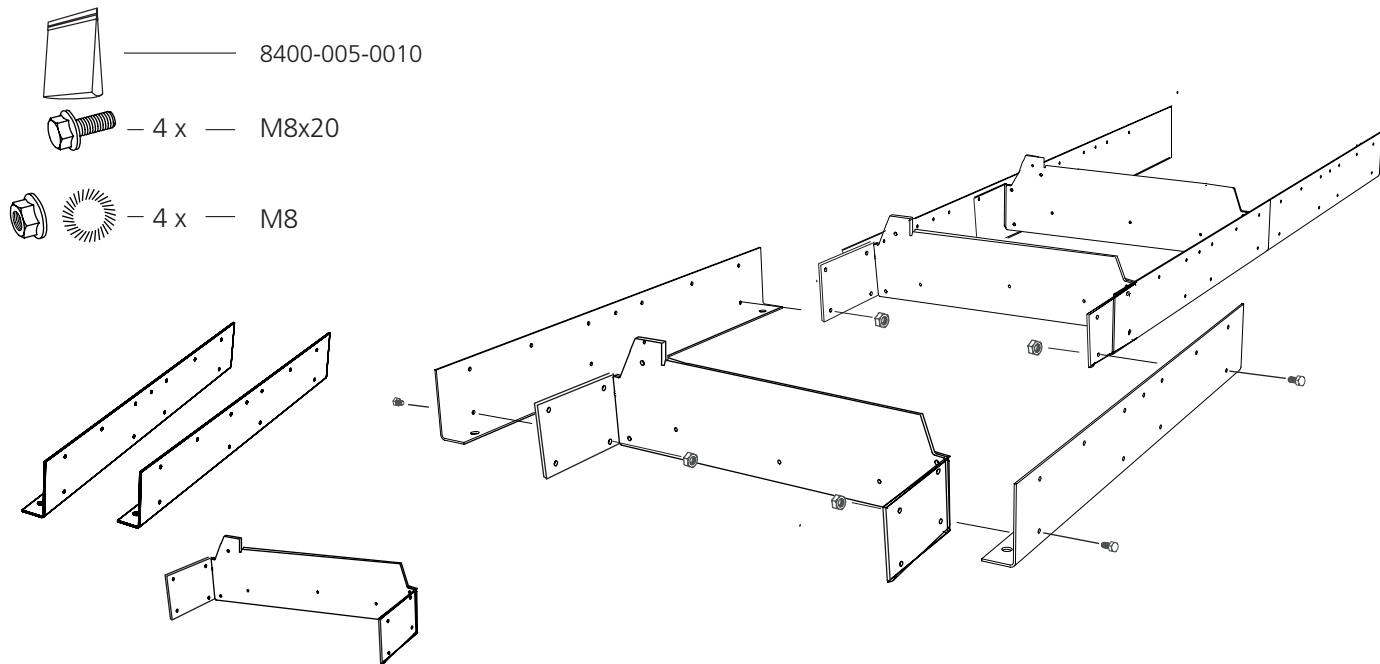

6

Assemble the rail sections with the log bed. Note that these must only be fitted in the lower hole and tightened loosely.

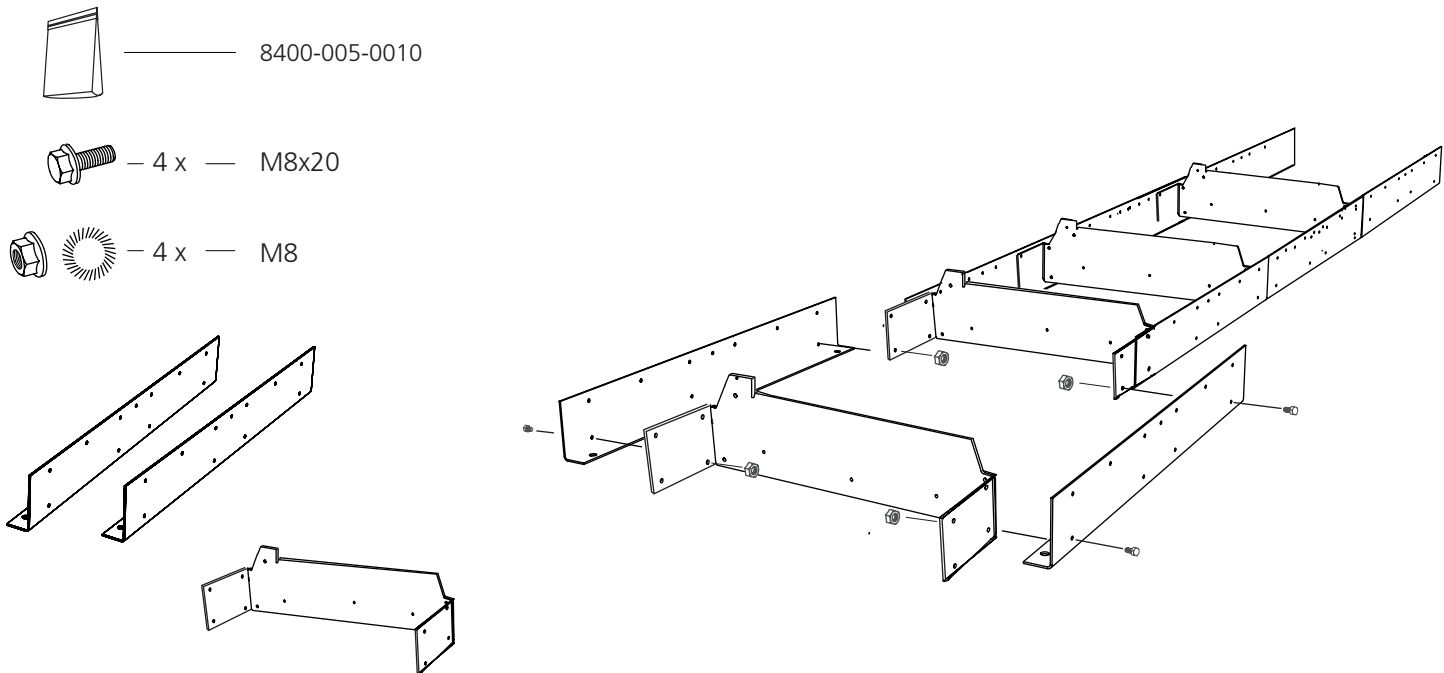

7

Assemble the rail sections with the log bed. Note that these must only be fitted in the lower hole and tightened loosely.

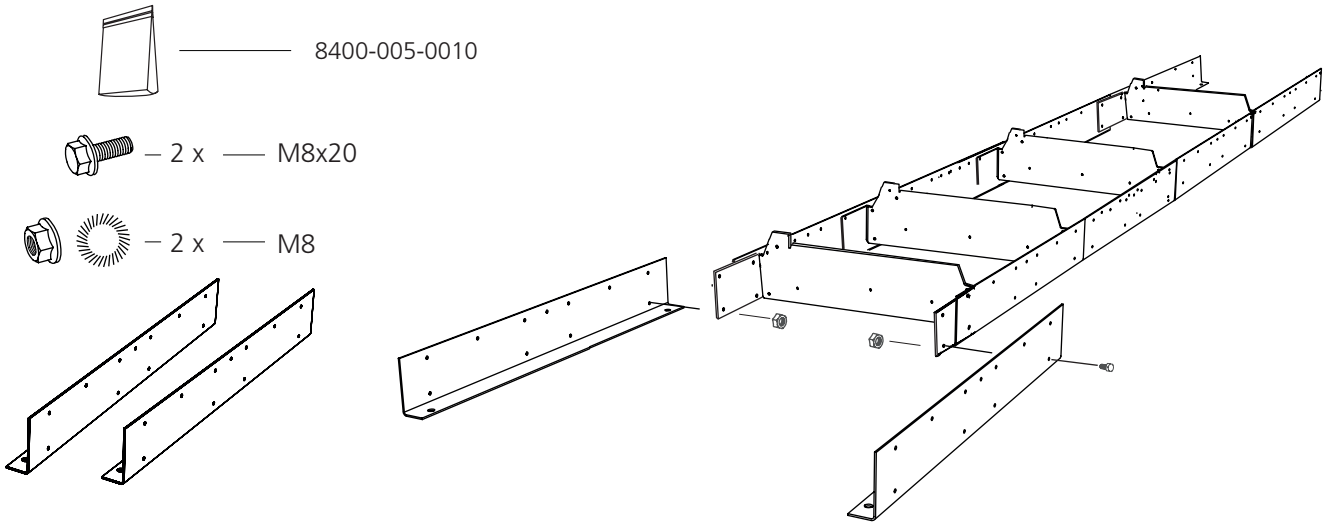

8

Fit the inner end cap plates to the outer ones. Note that the two shock absorbers must be mounted in the upper corners.

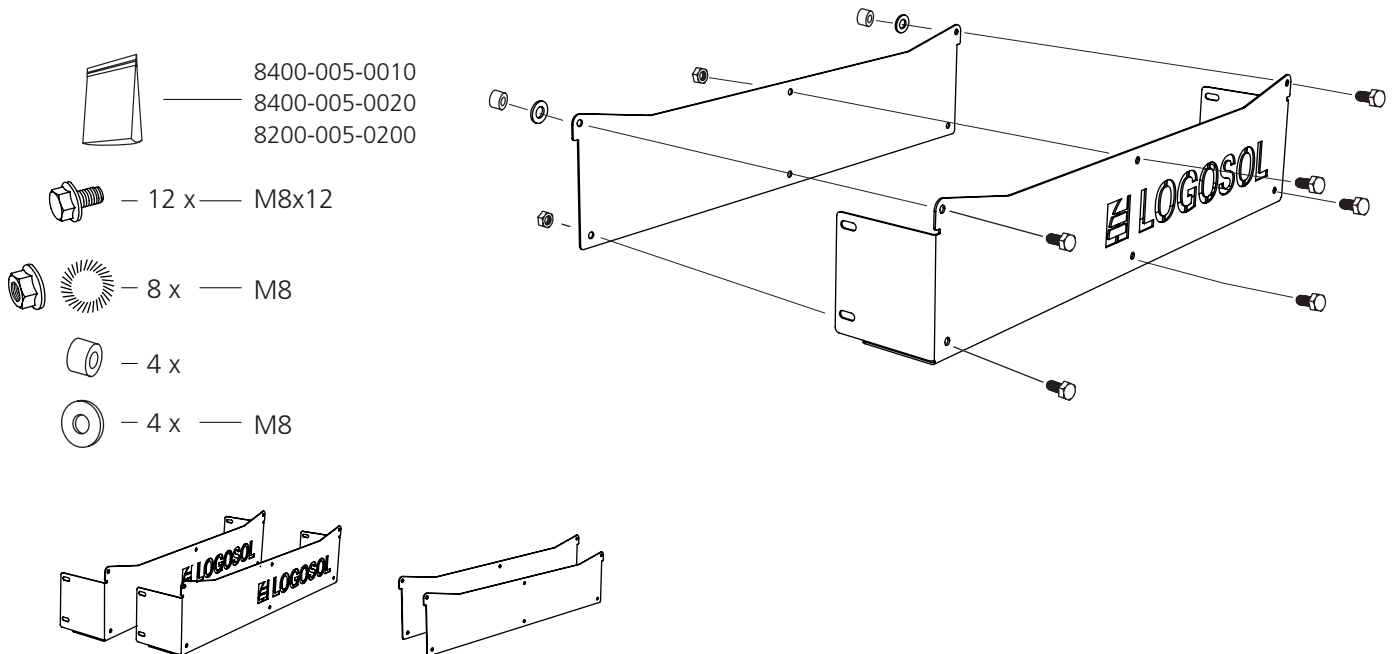

9

Fit the end piece to the end of the rail. Mount only in the lower holes. Then repeat the installation procedure at the other end of the rail.



8400-005-0010



4 x M8x20



4 x M8

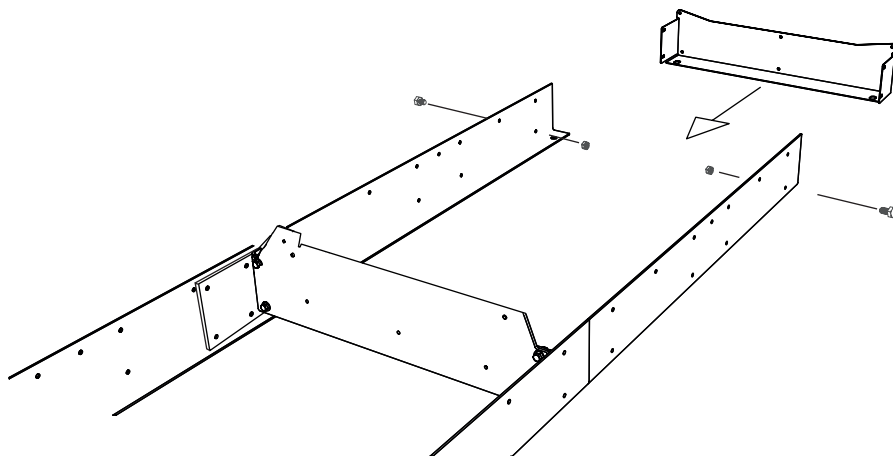
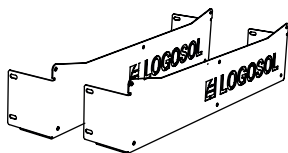

10

Assemble the pieces of rail. Start with a short piece of rail (3 holes) to be placed at the end of the rail. Tighten the piece loosely.



8400-005-0010



3 x M8x20



3 x M8

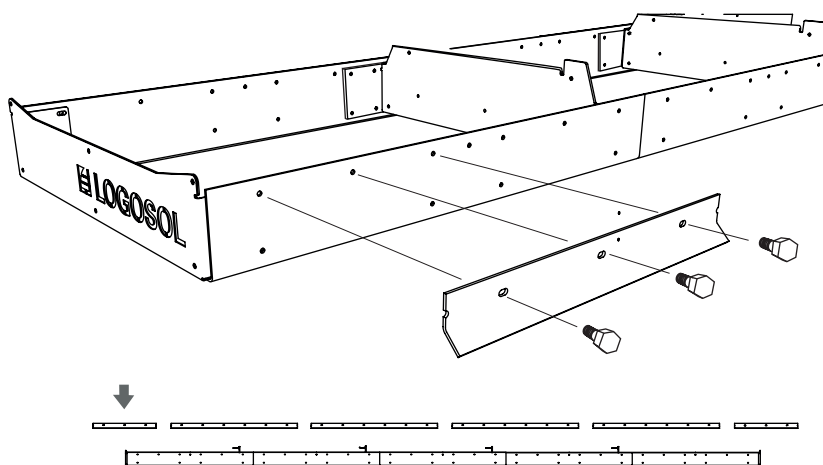
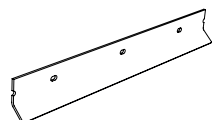

11

Fit the next two pieces of rail. Tighten the screw joints loosely.



8400-005-0010



— 12 x — M8x20



— 12 x — M8

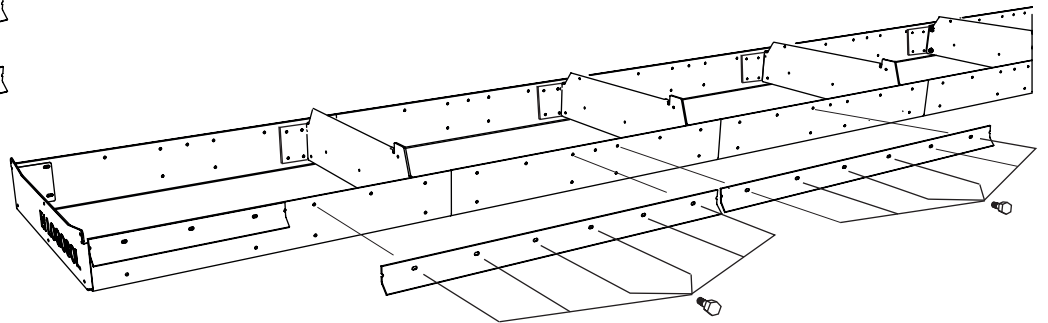
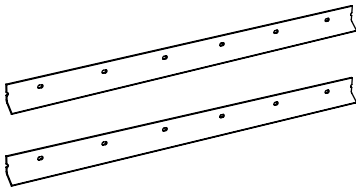
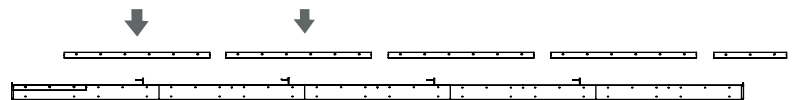

12

Fit the last three pieces of rail. Note that the short piece must be located at the end of the rail. Tighten the screw joint loosely.



8400-005-0010



— 15 x — M8x20



— 15 x — M8

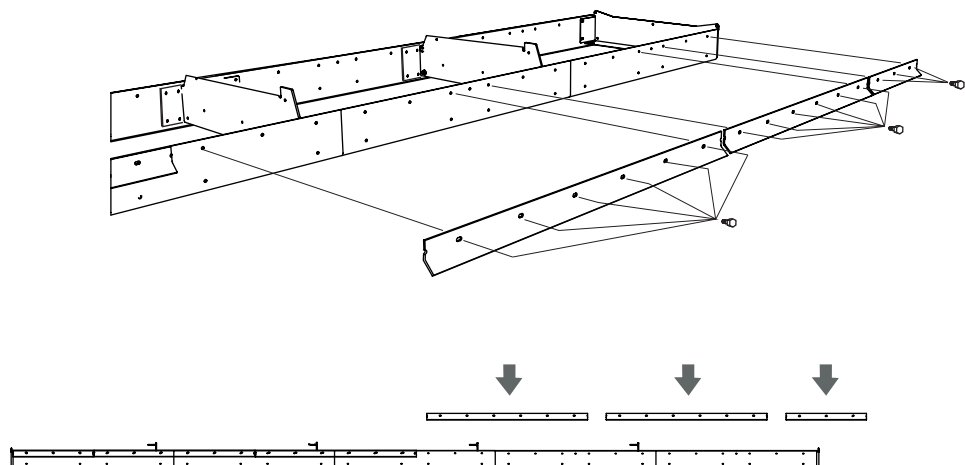
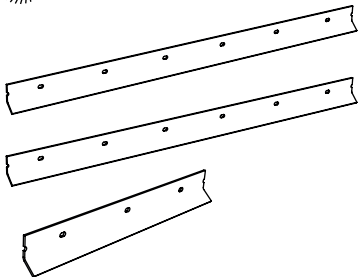

13

To complete the assembly of the rail pieces, repeat the assembly steps (10-12) on the other side of the rail.

14

Fit the adjusting nuts on the feet.

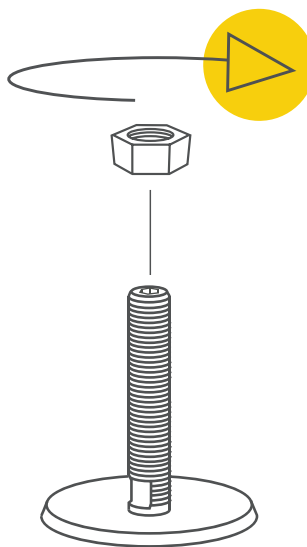
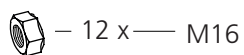
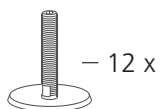
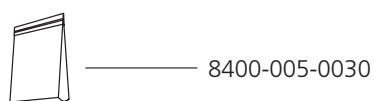

15

Fit the feet to the rail and secure them using the locking nuts.

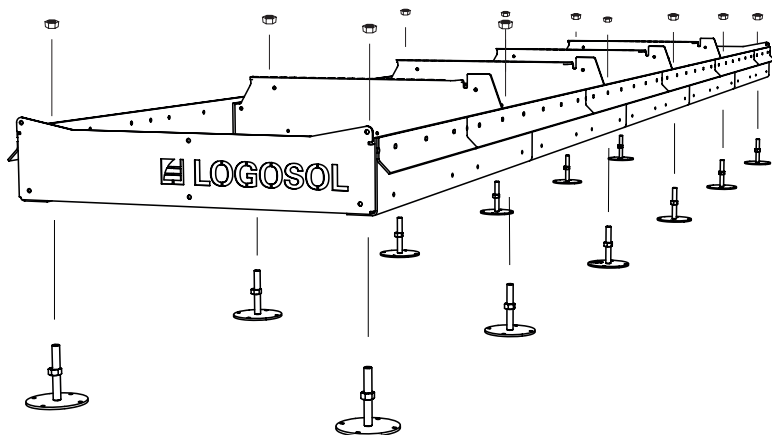
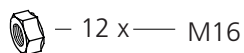
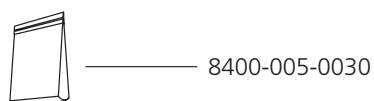



Well done!

Now work continues on setting the rail

SETTING: RAIL

(Tools are not supplied with the sawmill.)



Read through all the setting instructions before starting work, then follow the instructions step by step as you work.



Now it is time to adjust the rail. The aim is to make both sides of the rail as flat as possible. Read the instructions, and take care.

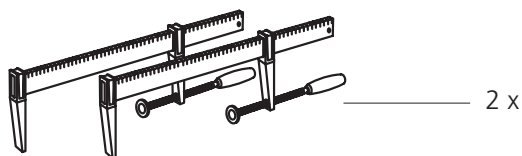

SETTING: RAIL

1

Start setting the rail by securing a cord between the alignment holes in the ends of the rail.

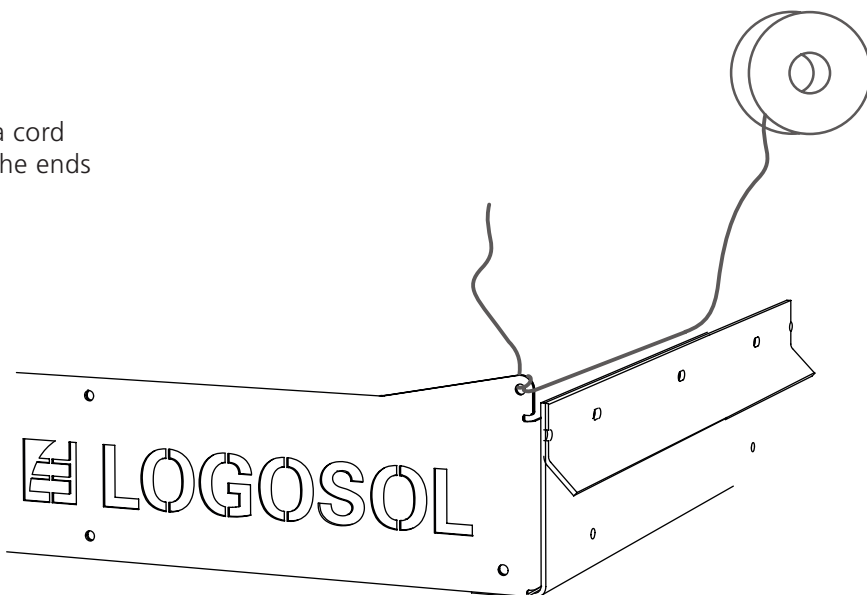
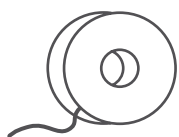

2

Position 2 nuts between the cord and the rail to act as a spacer. Make sure that the nuts are placed at the ends of the rail and lift the cord.



8400-005-0010



- 2 x - M8

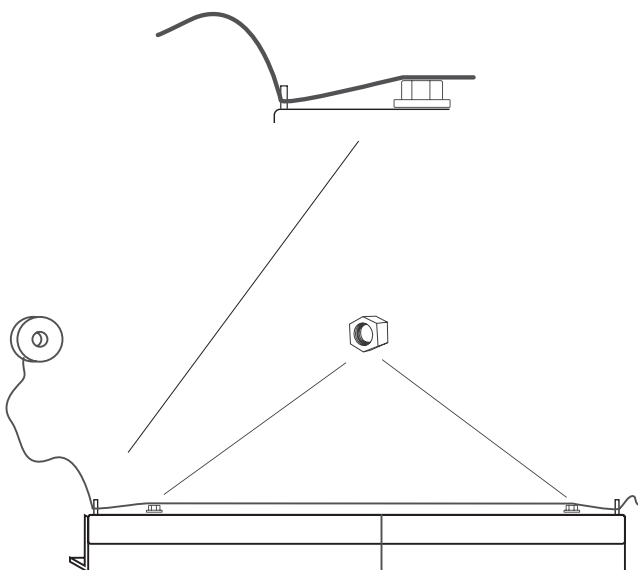

SETTING: RAIL

3

Now aim and measure along the string to check that the distance between the string and the rail is consistent along its entire length. The aim is to achieve even spacing over the entire length of the rail. To adjust the straightness, it may be useful to insert wedges under the rail in places where the straightness deviates.

IMPORTANT!

This step is critical to sawmill accuracy, so take care and spend extra time working on this step.

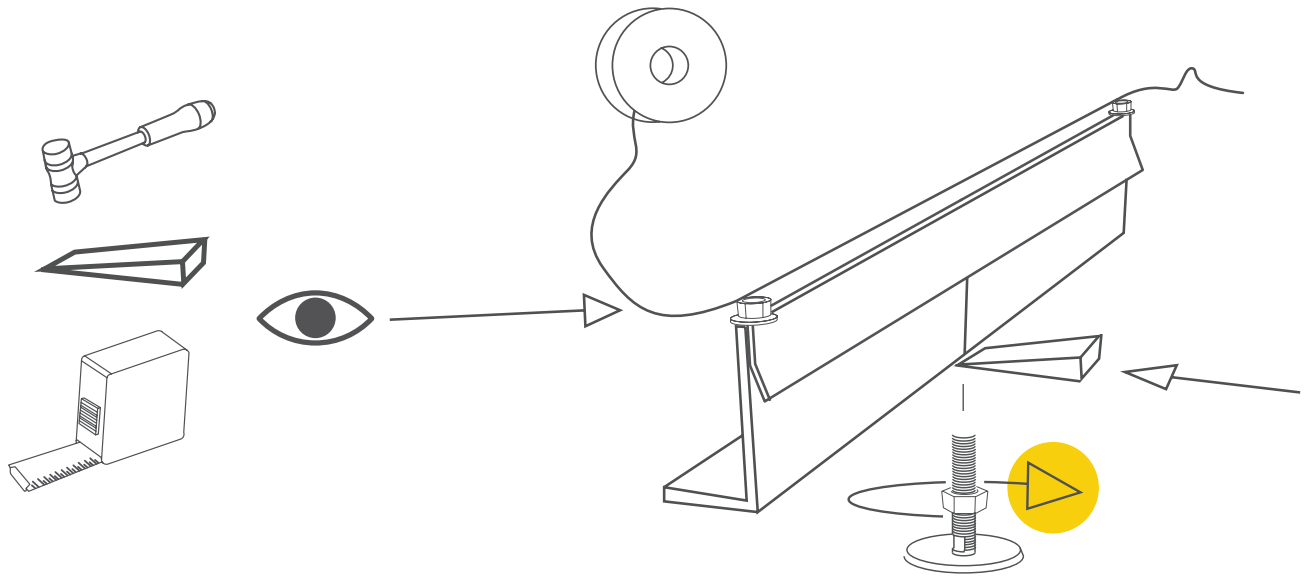

4

Once the rail has been straightened, check that all rail joints are even and that the outer rail plates are at the same height as the ones on the inside. The aim is to ensure that all joints are as even as possible. Adjust the screw joints and tighten as necessary.

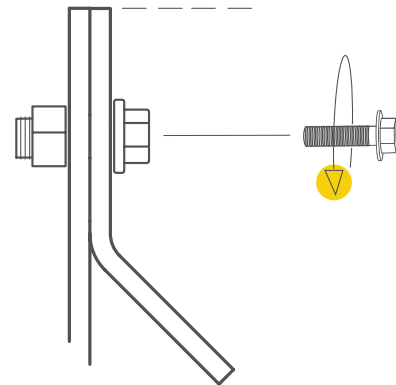

5

Tighten the aligned half of the screw joints for the rail when the rail is aligned over its entire length and the joints are even. Then repeat this procedure on the other side of the rail to complete the adjustment. The cord and nuts are then removed.

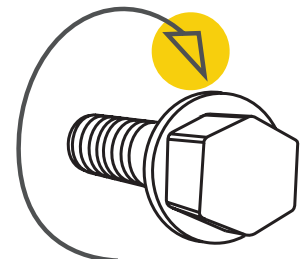



Well done!

FINAL ASSEMBLY: RAIL



Read through all the assembly instructions before starting assembly, then follow the instructions step by step as you work.

The remaining installation work on the rail will now begin.

1

Fit the log tensioning profiles on the log bed.
We recommend installing the profile on beds 2 and 4.

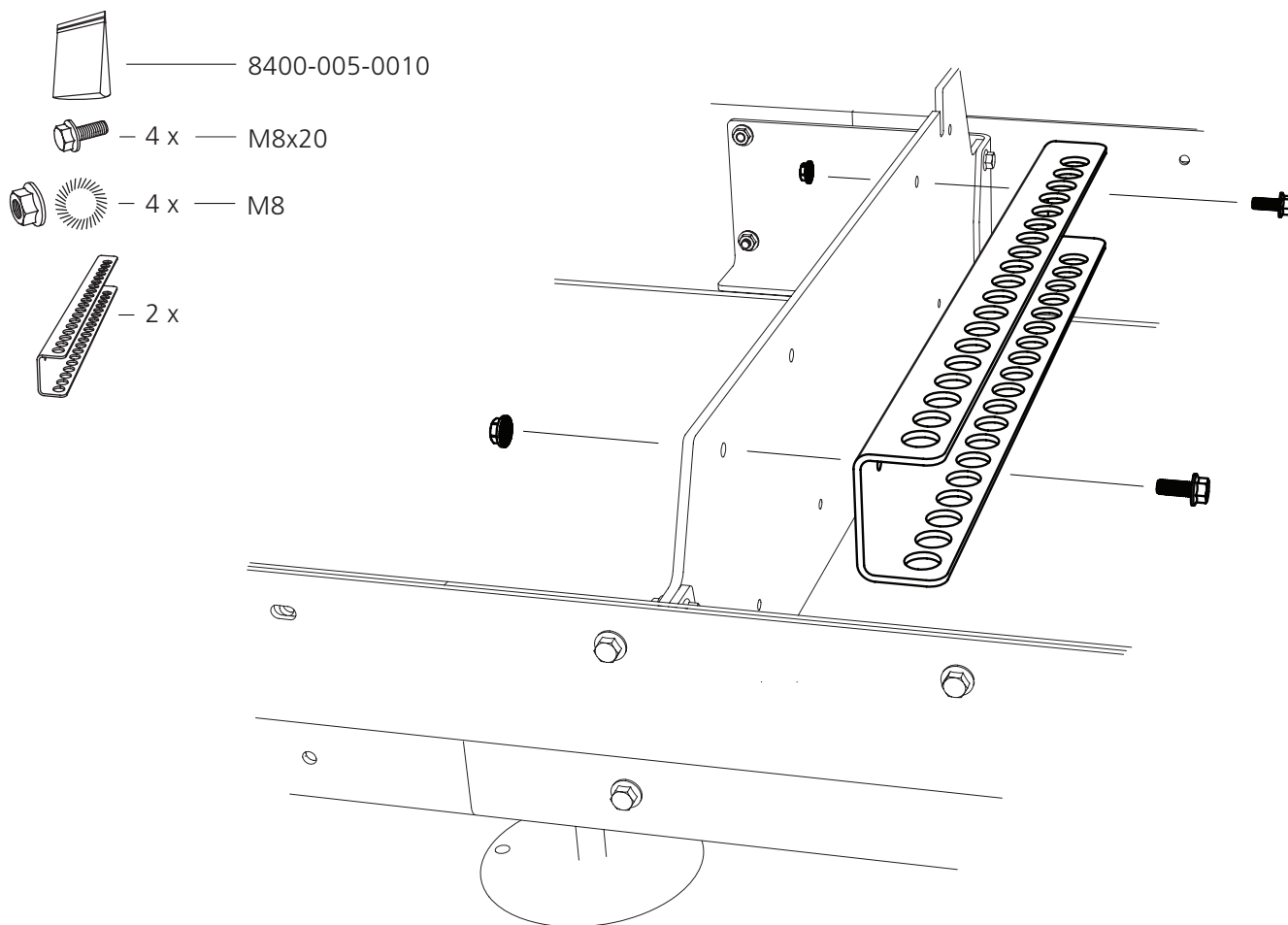

FINAL ASSEMBLY: RAIL

2

Fit the adjustment arm for the log support to the log bed.

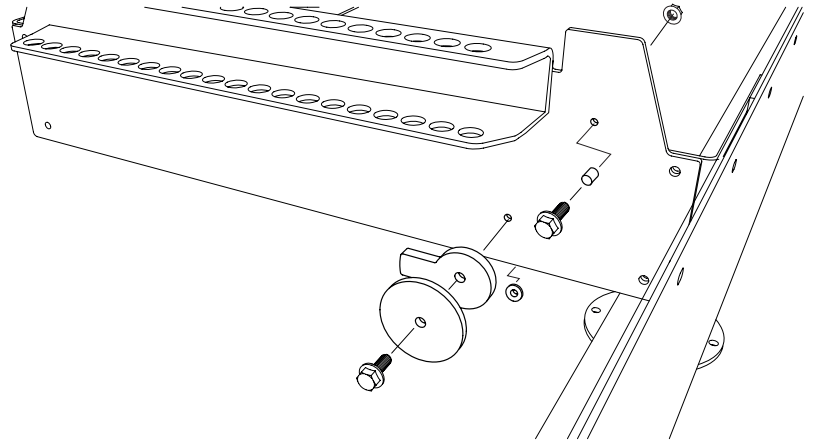
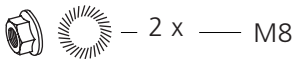
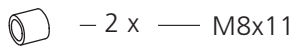
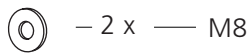
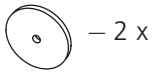
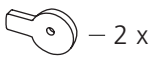
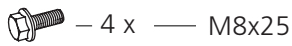
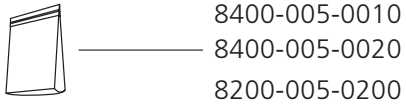

3

Fit the log support in the log bed.
Then repeat the installation procedure
for the second log bed.

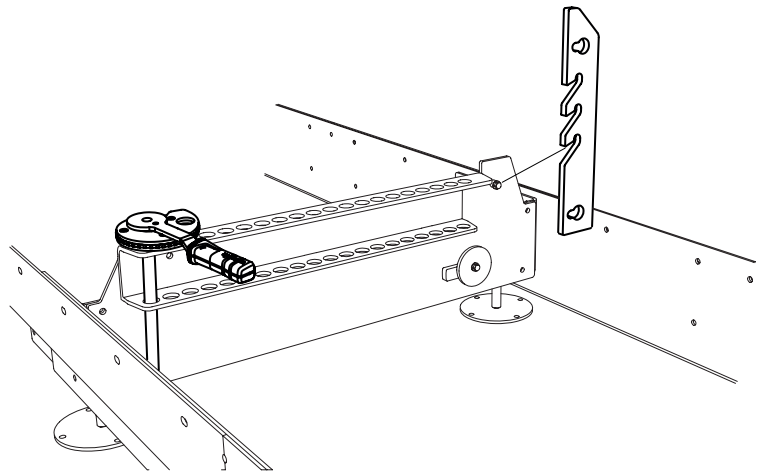
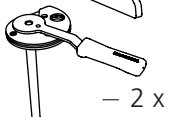
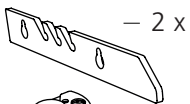

4

Fit the spacers for the log support storage in the sides of
the rail. Existing M8x20 screws are replaced by M8x30,
these 4 M8x20 screws are left over.

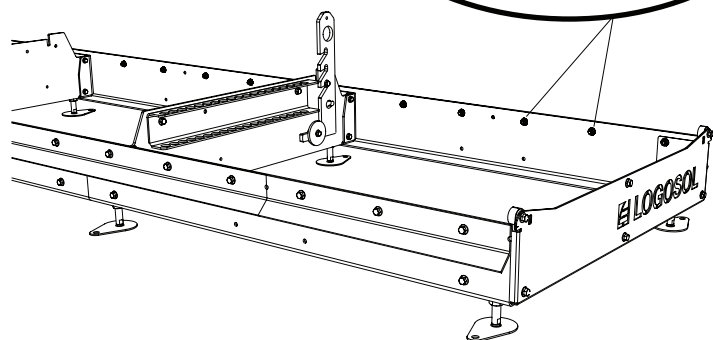
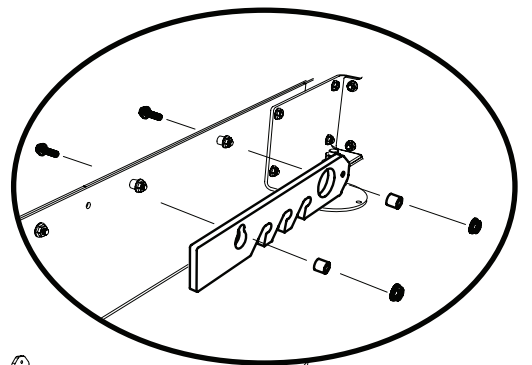
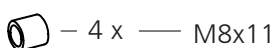
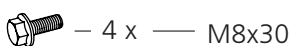
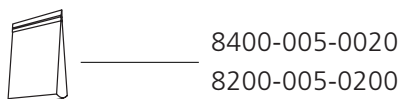



Well done!

It is now time to mount the saw head on the rail.

SAW HEAD

The saw head is partly assembled when supplied. The rail bar tipping wheels must be installed as soon as the saw head has been placed on the rail. After installing the tipping wheels, to ensure proper functioning of the sawmill the machine must be finally assembled and adjusted as described in the adjustment sequence provided in the manual.



IMPORTANT!

It is important to adjust the saw head before starting to ensure satisfactory sawing and the correct functioning of the sawmill. Carefully follow the adjustment sequence! Certain adjustments affect other machine settings.

SAW HEAD WEIGHT: 178 KG

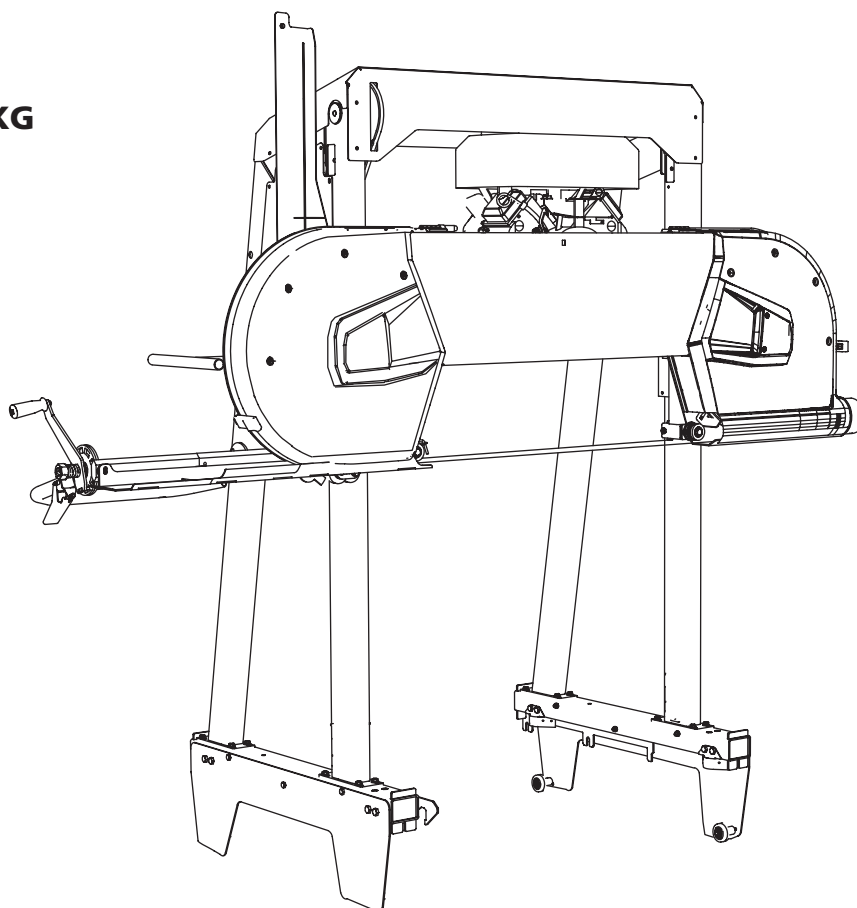

THE SAW HEAD

INSTALLING THE SAW HEAD ON THE RAIL

Lift the saw head into place on the rail. The saw head weighs 178 kg in total. Use an approved lifting sling attached to the sawhead's lifting points, as shown in illustration A or B. Lift the saw head using the appropriate lifting gear.

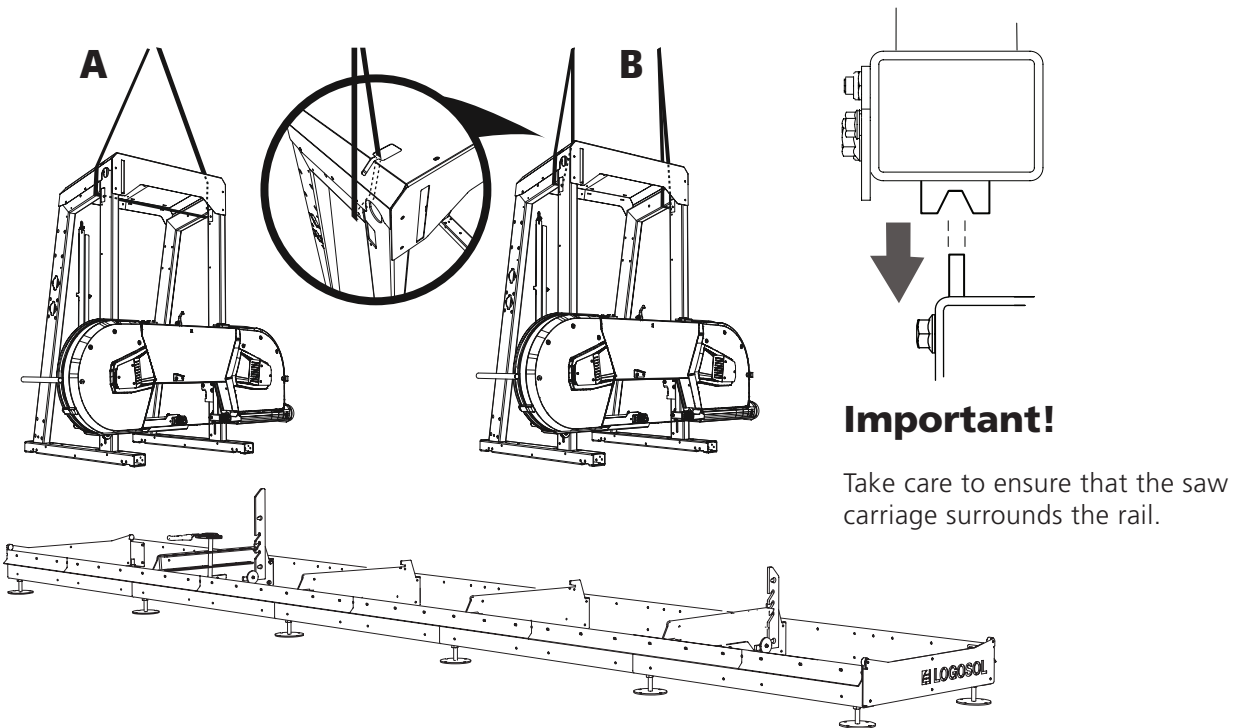

Important!

Take care to ensure that the saw carriage surrounds the rail.



Danger, overturning hazard!
Critical assembly.



The anti-tip wheels must be mounted on the underside of the saw carriage when the saw head is mounted on the rail.



Start by removing the flange nuts on the inside of the bogie tube. Leave the screws where they are. They will be needed for installation later.

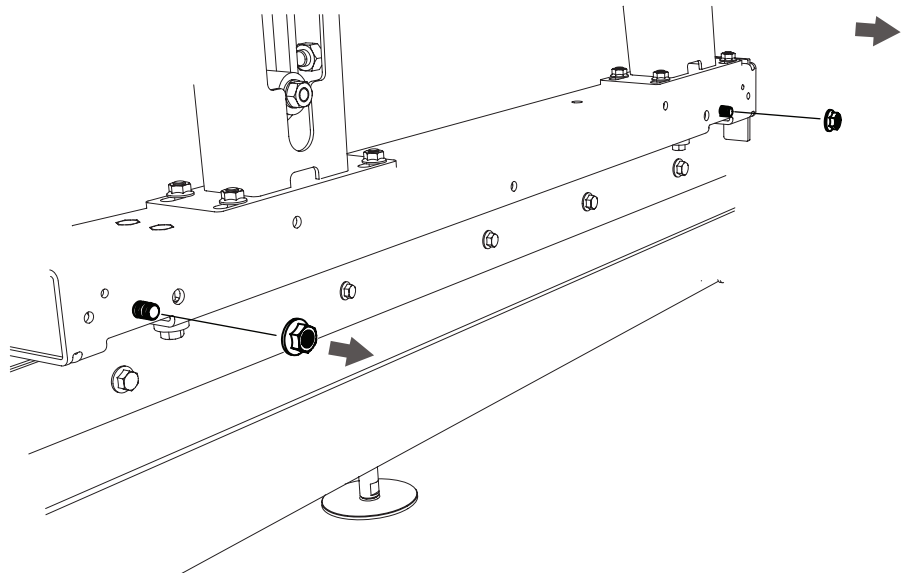



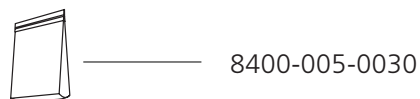

THE SAW HEAD

2

Fit the wheels and spacers to the anti-tip plate. Then repeat the installation procedure for the second anti-tip plate.



-  — 2 x — M6
-  — 2 x — M6x35
-  — 2 x — M6
-  — 2 x

3

Fit the anti-tip plate on the bogie tube. Use existing nuts from step 1. Then repeat the installation procedure for the other side of the machine. Fit the rail scraper.

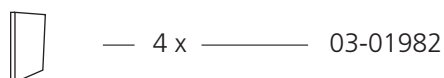

4

Tighten the anti-tip wheels by pushing them upwards in the inclined groove. Move them upwards so that they brace against the underside of the pipe. Then repeat the adjustment procedure on the other side of the machine.

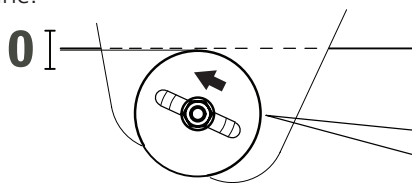

5

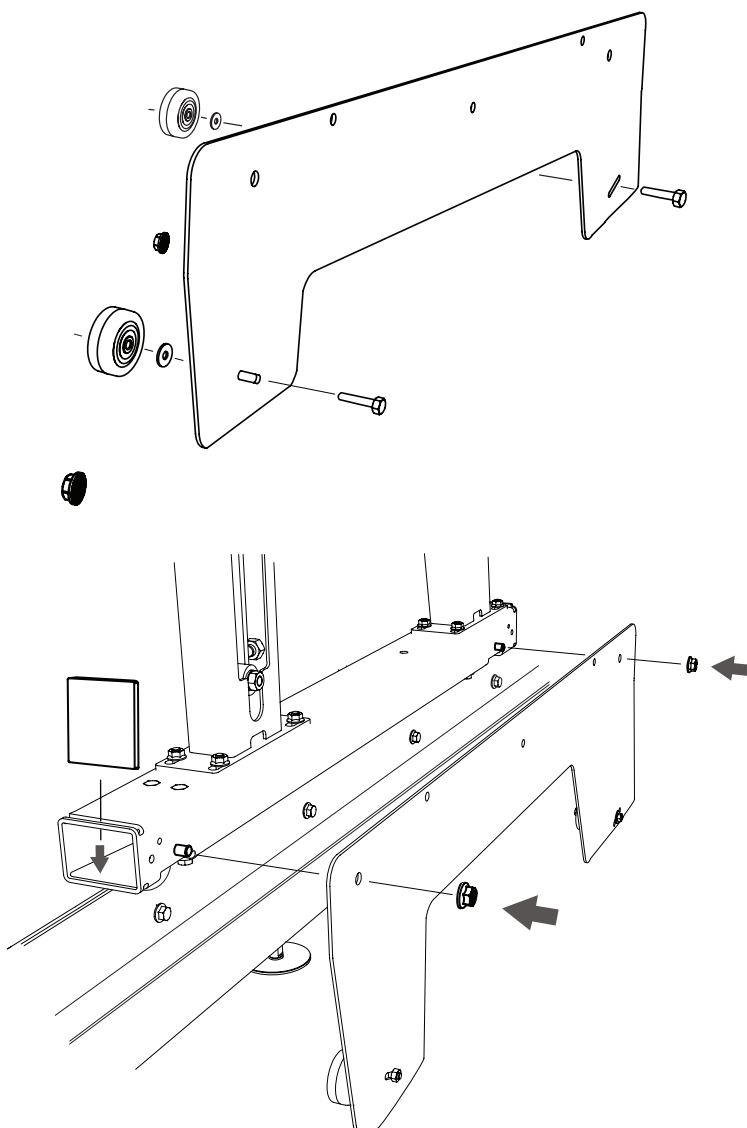
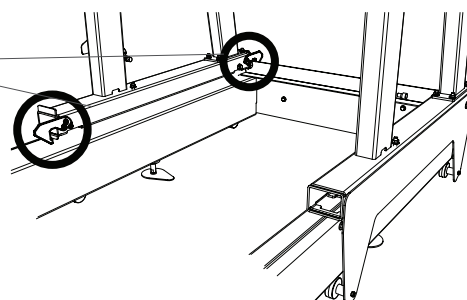
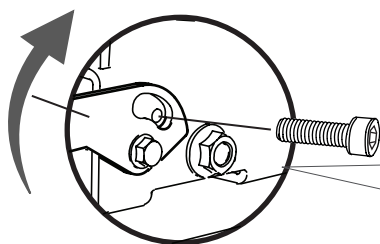
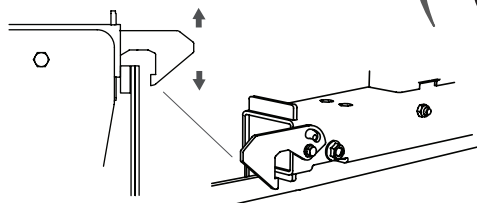
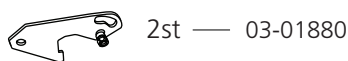

FINAL SAW HEAD ASSEMBLY

The saw head is assembled on delivery of the sawmill, except for the motor and the handle and crank. Follow the instructions below to complete sawmill assembly before initial start-up. Assembly work begins with the crank and ends by connecting the throttle cable and installing the sawmill motor. Follow the installation instructions and take care with the assembly work.



Read through all the set-up instructions before starting to set up, then follow the instructions step by step as you work.

1

Numbering for installation sequence



Well done!

Crank complete

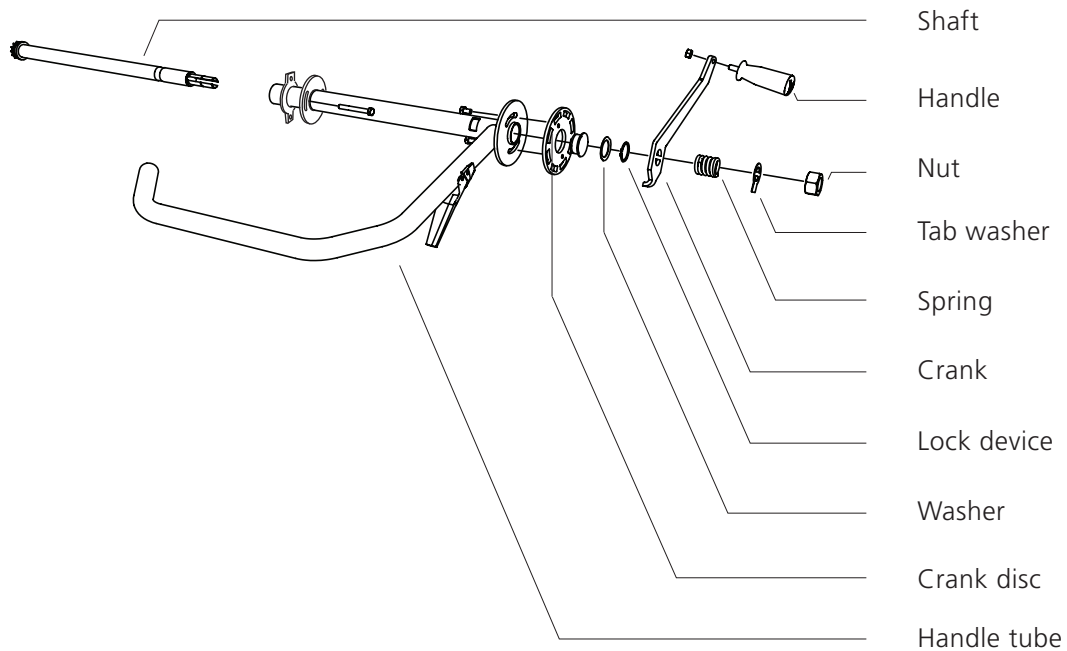

FINAL SAW HEAD ASSEMBLY

1

Insert the handle into the main post

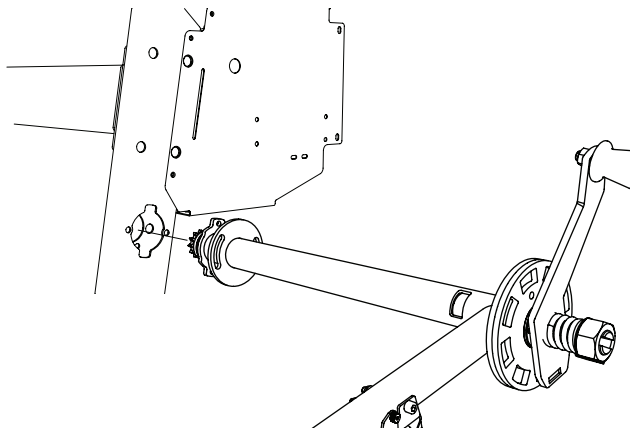

2

Secure the handle in place using the prefitted short fastening screws.

 — 2 x — M8x16

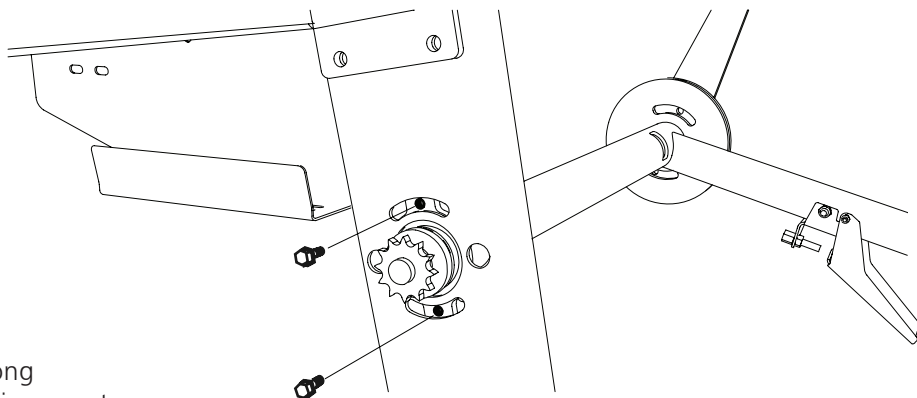



3

Secure the handle in place using the long fastening screws. Please note that the inner nut must be positioned so that the hex head of the bolt aligns with the outside of the tube.

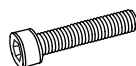
Use the prefitted screws for this assembly.

 — 2 x — M8x60

 — 2 x — M8

 — 2 x — M8

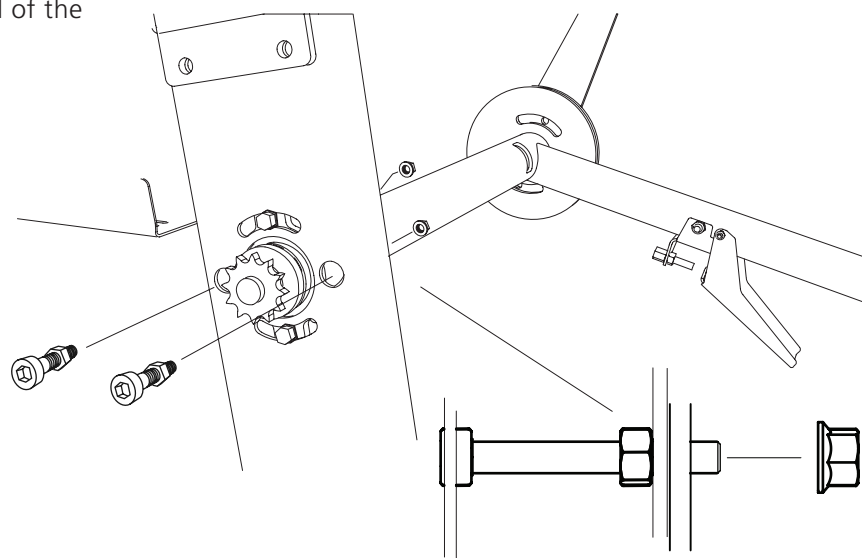

FINAL SAW HEAD ASSEMBLY

4

Tension the chain using the chain tensioner.

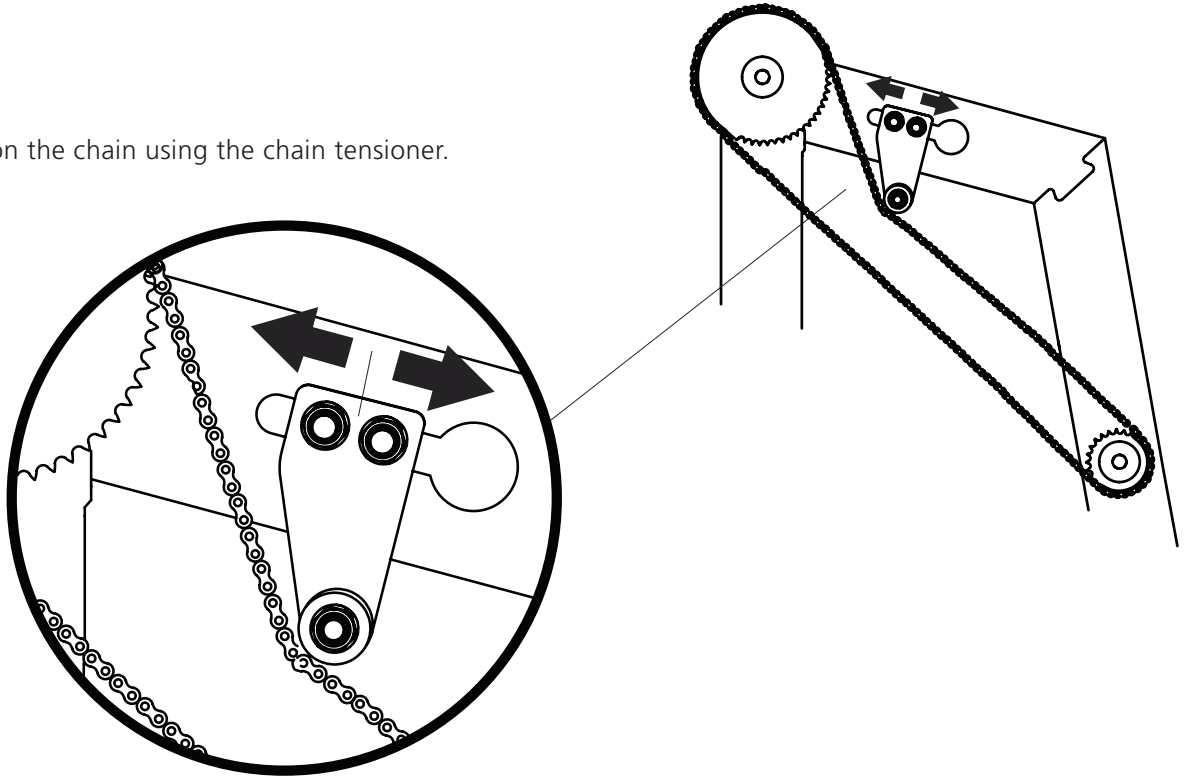

5

Fit the crank. Liberally grease the crank threads.

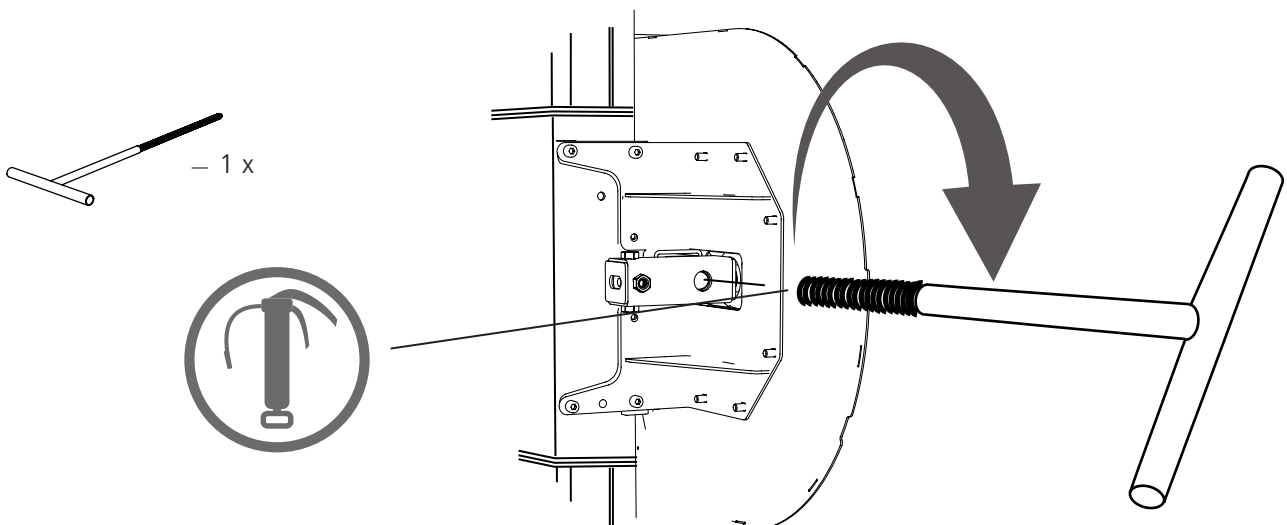

INSTALLATION OF THE MOTOR: SEE THE SEPARATE USER MANUAL



It is now time to fit the engine. The instructions for fitting the engine are supplied in a separate attachment: see the instructions for the engine you will be working with. When assembly is complete, carry on with the section entitled Adjustment sequence on the next page of this user manual to complete the adjustment sequence before starting the machine.

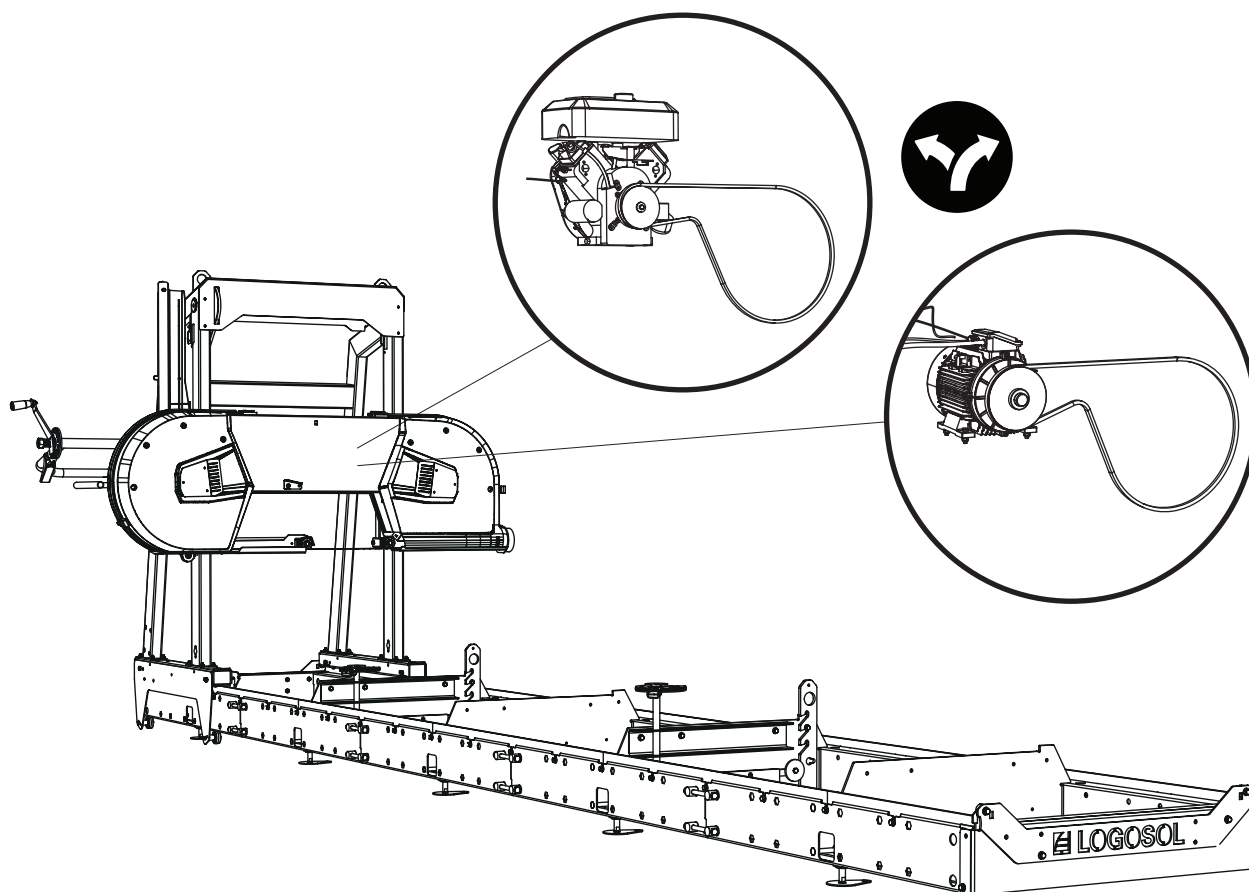

ADJUSTMENT SEQUENCE



Read through all the set-up instructions before starting to set up, then follow the instructions step by step as you work.



IMPORTANT!

It is important to adjust the saw head before starting to ensure satisfactory sawing and the correct functioning of the sawmill. Carefully follow the adjustment sequence! Certain adjustments affect other machine settings. That is why it is important to follow the sequence below.

- 1 Adjust the rail horizontally
- 2 Adjust the wheels
- 3 Longitudinal blade position / Adjust the longitudinal blade position
- 4 Adjust the saw blade so that it is parallel to the log beds
- 5 Adjust the adjustable blade guide horizontally
- 6 Adjust the blade so that it is parallel to the rail
- 7 Tensioning of the throttle cable

ADJUSTMENT SEQUENCE

1

ADJUST THE RAIL HORIZONTALLY

It is important that the rail is completely level so as to ensure that it functions well. We have previously set the straightness of the rail in longitudinal direction. Now the rail has to be adjusted horizontally along the short side. Place a spirit level on a log bed, then adjust the rail using the feet until the rail is horizontal. Then repeat this procedure for all log beds until the whole rail is horizontal.

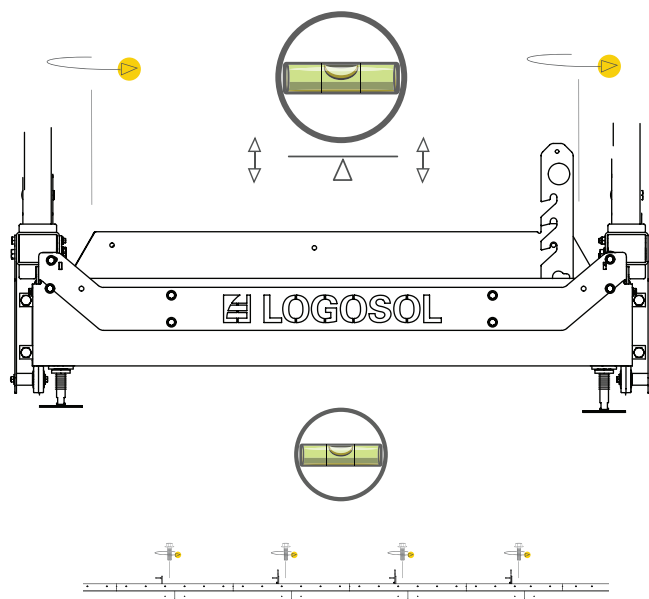

ADJUSTMENT OF THE FEET

The feet can be adjusted from above using an Allen key. Once adjustment is complete, the position is fixed with the check nut on the inside of the tube.

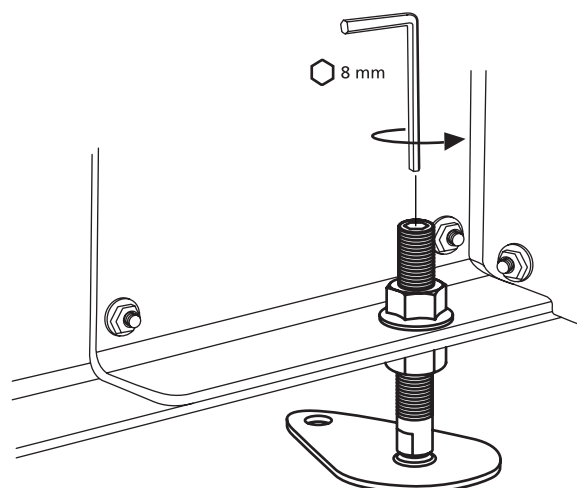

2

ADJUST THE WHEELS

The angle of the wheels must be adjusted so that they are perpendicular to the log beds. With the saw head set to the bottom position, check the perpendicularity between the wheels and the log beds. It is useful to place the angle iron on a straightedge extending between two log beds. Adjust by loosening the lock nut first, then tightening the adjusting screws on the wheel axle until perpendicularity is achieved. Tighten the lock nuts and adjusting screws.

Place the set square on a straightedge

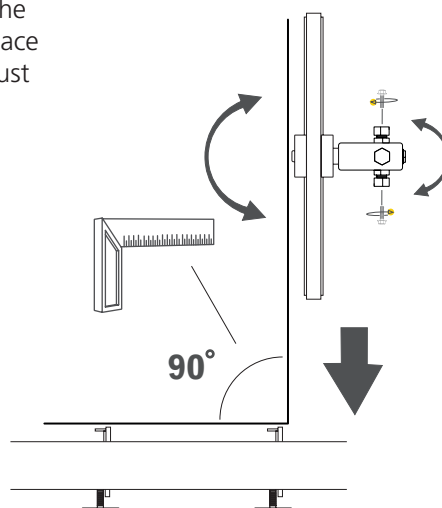
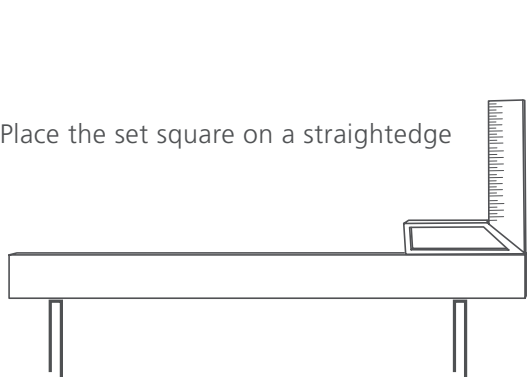

ADJUSTMENT SEQUENCE

3

LONGITUDINAL BLADE POSITION

The longitudinal blade position over the wheels is adjusted using the horizontal adjusting screws, i.e. the screws on the outside of the axle mountings. The lock nut must be opened first when adjusting the blade position. The adjusting screw must be turned clockwise to compensate if the saw blade wanders forward on the wheels. Turn the screw anticlockwise if the blade wanders backwards. Adjust in small increments. Tighten all lock nuts and adjusting screws when adjustment is complete.

TIP: You may need to loosen the upper adjusting screw slightly before adjusting the blade.

Loosen the locking screw

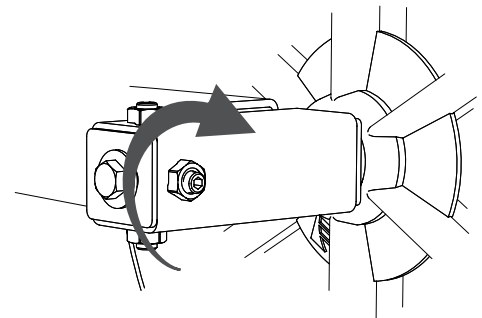
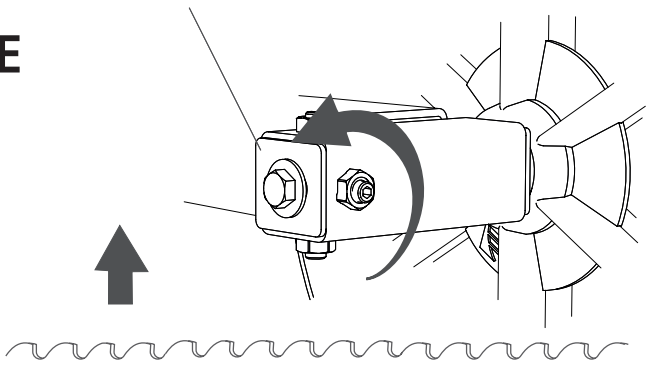

LONGITUDINAL BLADE POSITION

The position of the saw blade in the longitudinal direction is important for the sawing result. Positioning the blade with the blade body centred over the drive belt located in the recess in the wheel is recommended for best results.

Start by fitting the blade so that the protrusion on both sides of the drive belt to the sides of the blade body are of the same size. Then tension the blade. Spin the wheels manually and check that the longitudinal blade position on the wheels remains unchanged. Spin the wheels through at least three revolutions. Perform adjustment as instructed in the next paragraph if the blade wanders forward or back on the wheels. If the blade runs straight on both wheels, check that the blade runs in a straight line between the wheels. This is checked by looking along the trailing edge of the blade on the top of the wheels.

When the blade is running in a straight line. Close the covers and start the sawmill. Open the throttle so that the wheels start to turn, then release the throttle. Open the covers and check that the longitudinal position of the blade is unchanged. If so, the setting is correct.

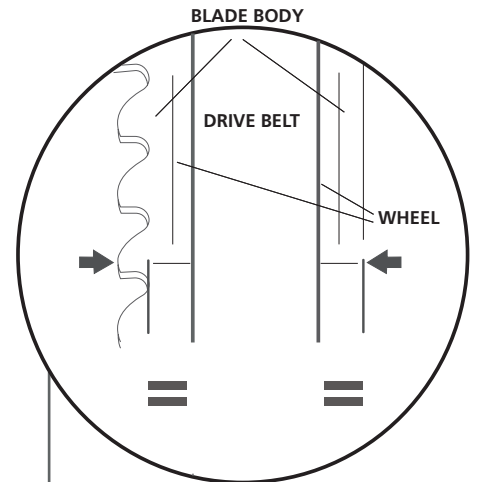

In this case, the blade body is defined as the part of the blade that is between the bottom of the tooth and the trailing edge of the blade.

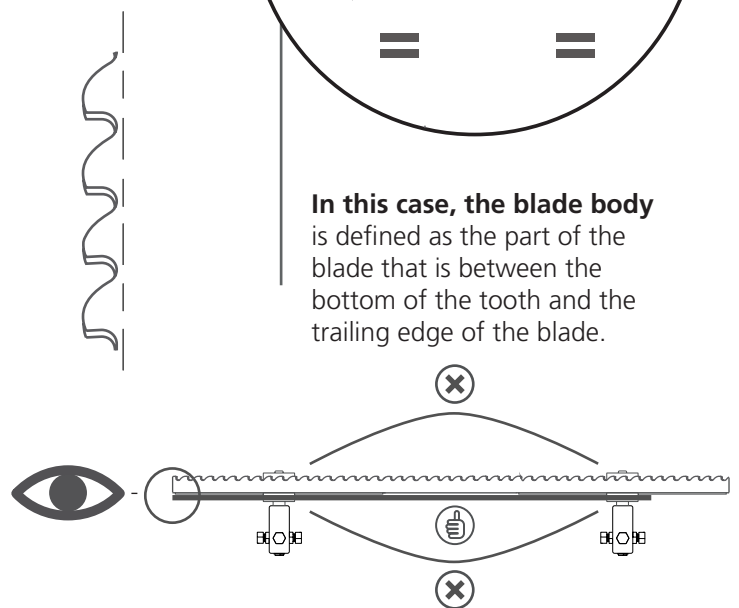

If the blade curves in the sawing direction, the blade is too far forward on the wheels. If it curves in the other direction, it is too far back.

ADJUSTMENT SEQUENCE

4

ADJUST THE SAW BLADE PARALLEL TO THE LOG BEDS

It is important for the saw blade to be parallel to the log beds to ensure the proper functioning of the sawmill. Measure the distance vertically down from the blade to the log bed, then note down the values.

It is important for the blade guide rollers to be removed for this setting operation.

Adjust the measurement difference between the measurement points. Tighten the saw head adjusting screws until the measurements match at both measurement points.

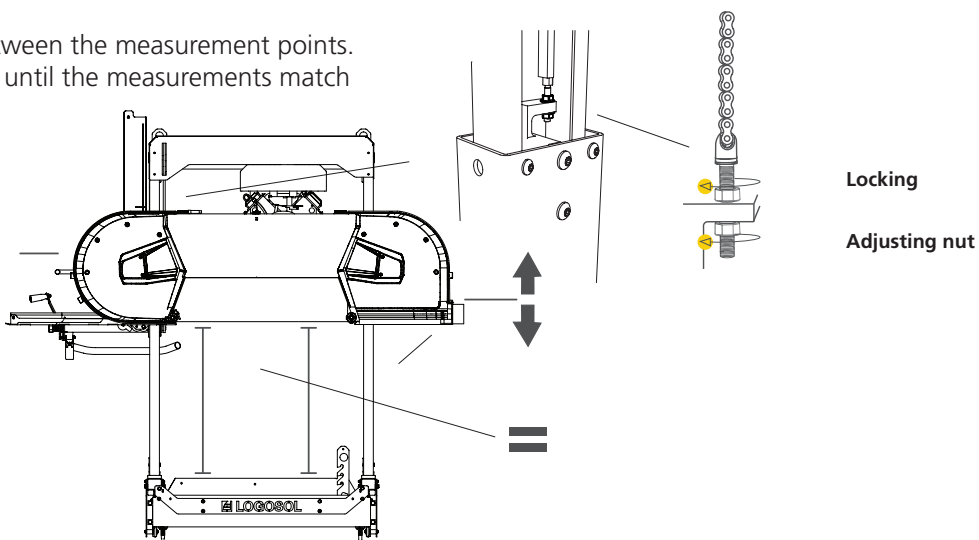
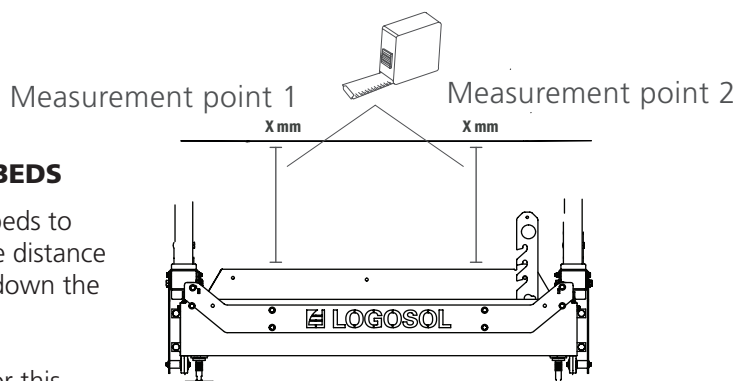

5

ADJUST THE ADJUSTABLE BLADE GUIDE HORIZONTALLY

The adjustable blade guide and guard needs to be adjusted so as to achieve straight kerfs in all positions. Install the blade guide rollers. Then move the blade guide and guard to its innermost position. Place a spirit level on top of the blade guide, then adjust until the blade guide and guard is horizontal. When this has been done, shim the fixed blade guide roller until the same dimension is achieved between the blade tension rollers and the log bed.

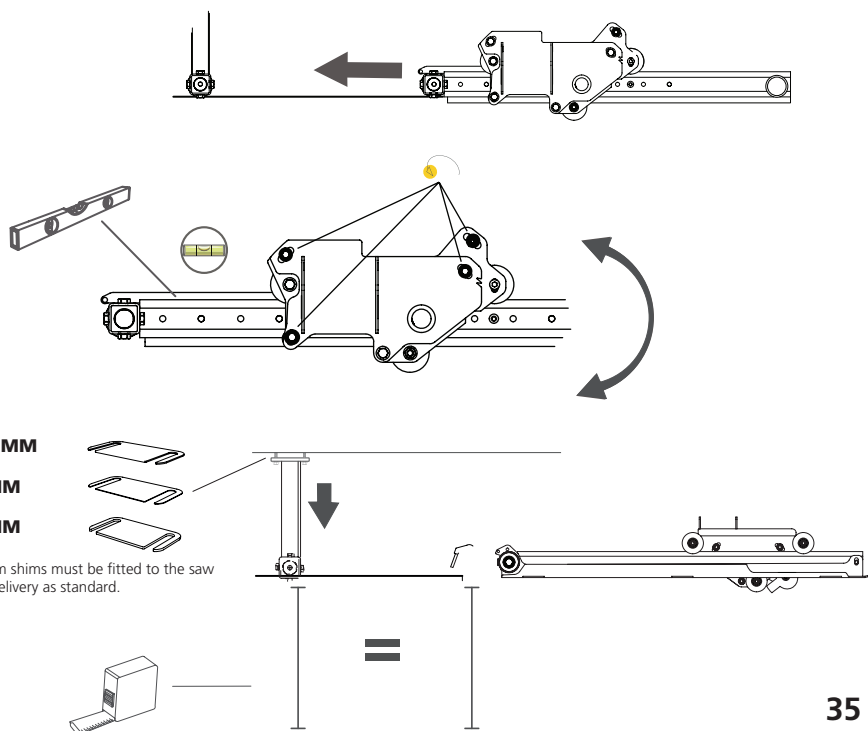

ADJUSTMENT SEQUENCE

TENSION THE BLADE GUARD ARM

It is important for the blade guard arm to move smoothly in the attachment plate to ensure proper functioning of the sawmill. Release the Allen head bolt on the blade guard plate, then push the wheel downwards using a screwdriver as illustrated.

Make sure the blade protection arm is straight between the wheels and runs smoothly.

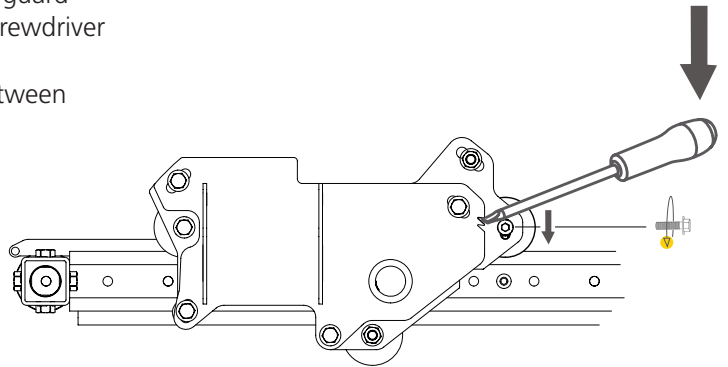

ADJUST THE BLADE GUARD ARM PARALLEL TO THE BLADE

To adjust the parallelism of the blade guard arm with the saw blade, loosen the three fastening screws on the outside of the attachment, then adjust the parallelism using the adjusting screw that attaches to the back cover.

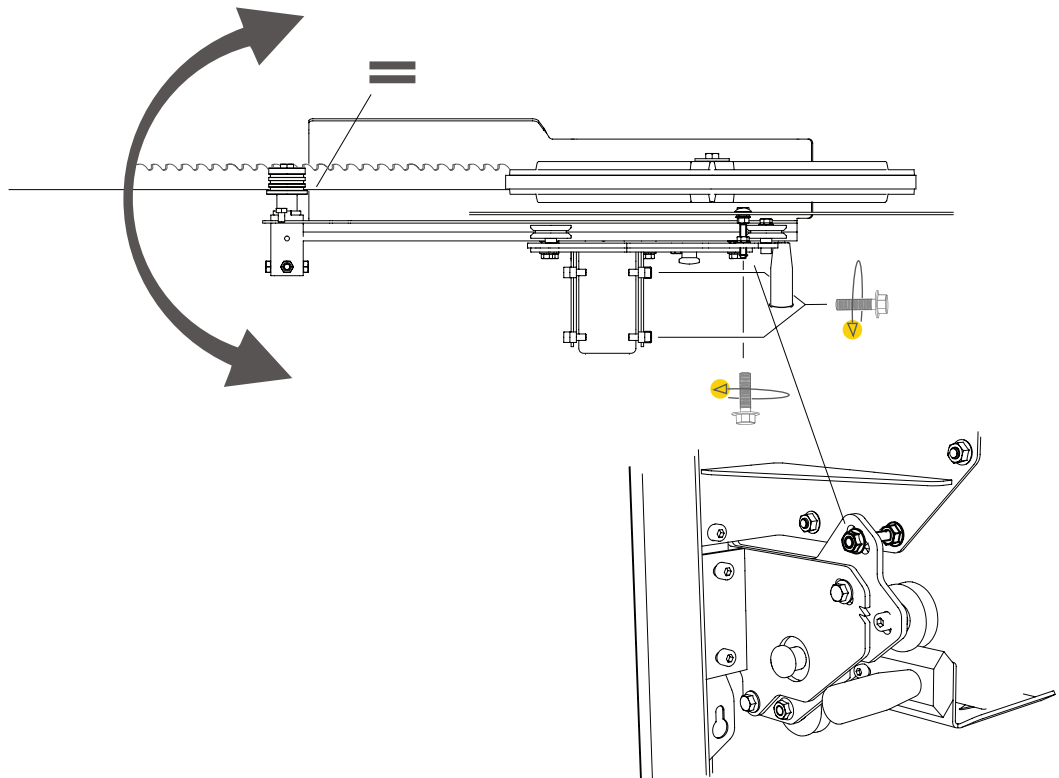

ADJUSTMENT SEQUENCE

6

ADJUST THE BLADE SO THAT IT IS PARALLEL TO THE RAIL

It is important for the saw blade to be parallel to the rail to ensure proper operation of the sawmill.

Place the Blade Align on the saw blade, as close to one of the blade guide rollers as possible.

Place the Blade Align over a tooth with no set.

Now measure from the leading edge of the Blade Align (measurement point 1) vertically down to the log bed. Note down the value from measurement point 1. Move the saw head, then repeat the measurement from the trailing edge of the Blade Align (measurement point 2). Compare the values. The values at measurement point 1 and measurement point 2 must be the same.

If the values are not the same, tighten the adjusting screws for the blade guide roller until the measurements match at both measurement points. One way of facilitating adjustment is to work on the basis of the value from measurement point 1, compare it with the value from measurement point 2, and then adjust measurement point 2 up or down by half the difference. When you have achieved parallelism, repeat the adjustment procedure at the second blade guide roller.

7

THROTTLE CABLE TENSION

The throttle cable tension can be adjusted by tightening the adjusting screw holding the cable housing. Undo the adjusting screw until depressing the throttle fully results in full throttle at the engine. Then lock the adjustment using the check nut.

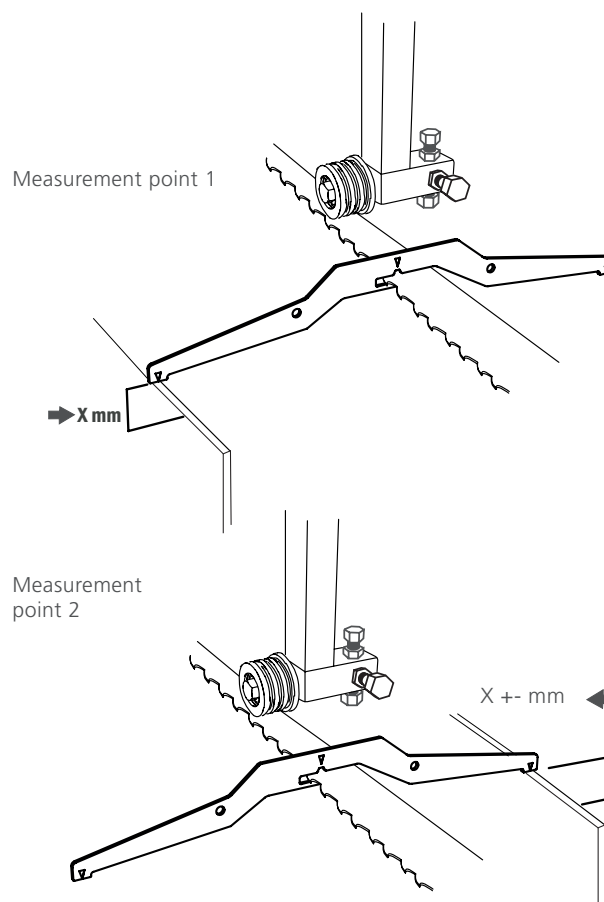

Adjust half the difference at measurement point 2

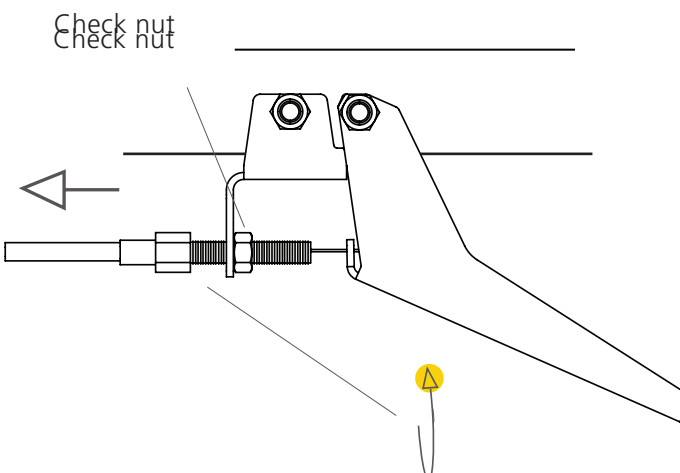
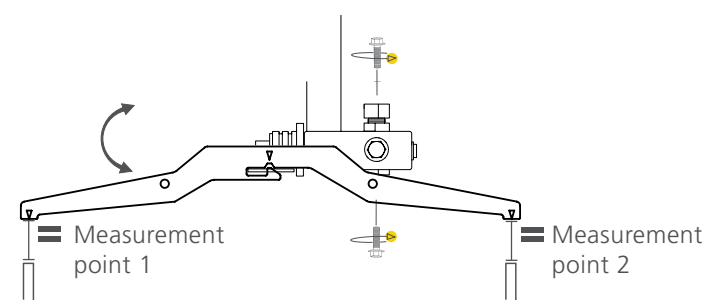

OTHER SETTINGS



Read through all the set-up instructions before starting to set up, then follow the instructions step by step as you work.



The following settings are important for satisfactory operation of the sawmill, but they do not affect one another and so there is no need to implement them in any particular order.

RAIL SCRAPERS

The saw carriage has rail scrapers at the ends. It is important to perform regular checks to ensure that these run against the rail.

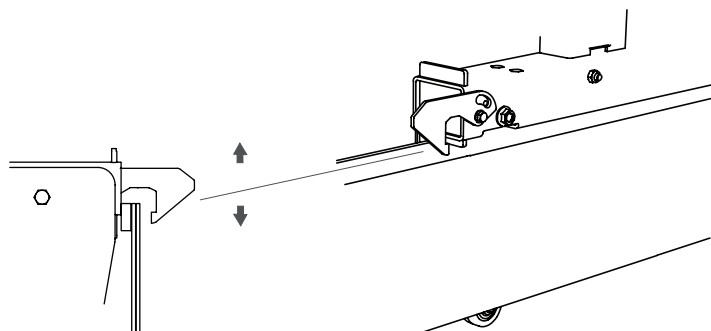

BLADE TENSION

Tension the saw blade by turning the T-handle to the right. Read off the blade tension on the gauge that can be seen inside the band wheel guards. The blade is tightened until the red line is centred on the arrow in the opening for the blade tension spring.

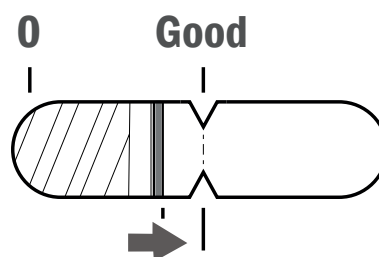

CHAIN LINKAGE

The handle's chain linkage must be extended to ensure that the lifting mechanism works properly. Start by loosening the tensioner's fastening screw, then move the tensioner towards the chain until the chain is tensioned slightly. Then tighten the screw joint.

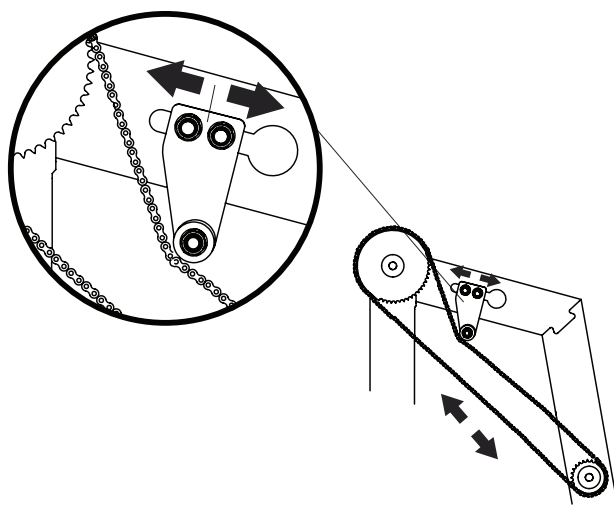

SET THE GAUGE

It is necessary to adjust the gauge so that it shows a correct value between the log bed and the blade. Proceed as follows: Measure the distance vertically down between the saw head and a log bed. Note down the distance. Now fit the magnetic gauge on the gauge plate so that its value at the top of the pointer matches with the value noted.

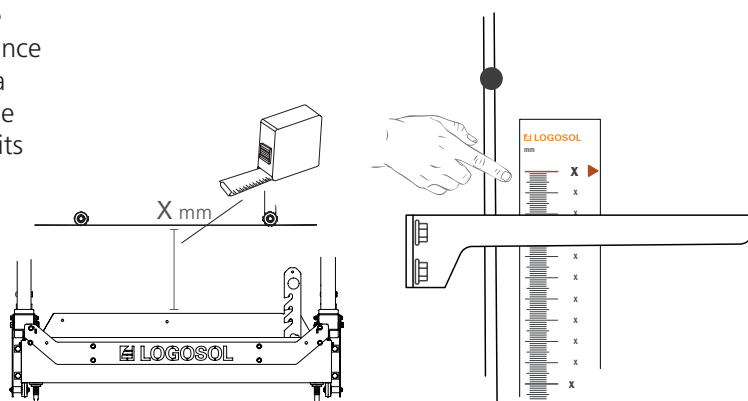

OTHER SETTINGS

LOG SUPPORT

It is important for the relationship between the log bed and the log support to be perpendicular to ensure the proper functioning of the sawmill. This is adjusted by turning the adjustment handle in the lower part of the log support. Check the perpendicularity using a set square.

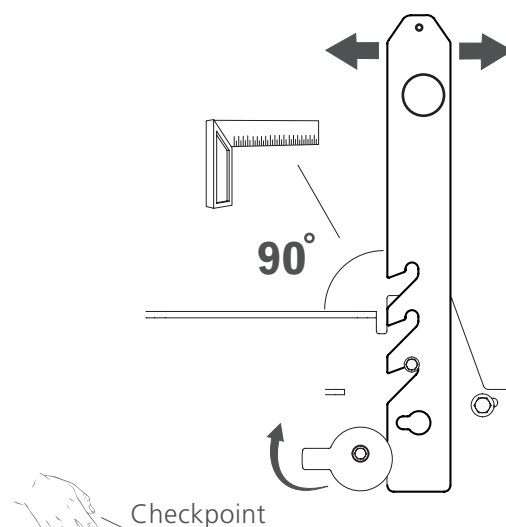

DRIVE BELT TENSION

The drive belt must be tensioned correctly to prevent it wearing on the pulley. The tensioning wheel can rotate around its lower attachment. Tension the belt until the value stated below is reached at the checkpoint.

Belt tension
3 kg Pressure
6 mm Deflection

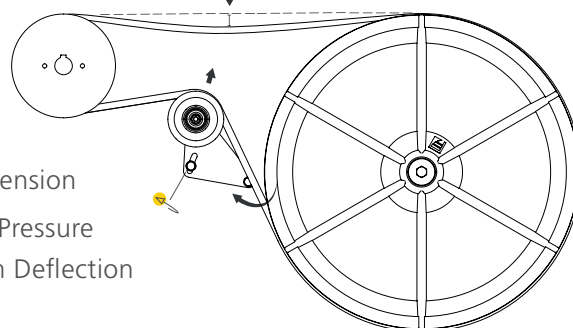

WATER RESERVOIR

The sawmill water reservoir needs to be filled before use. This is done in the tank opening on the back of the saw carriage. The tank volume is 7.5 litres.

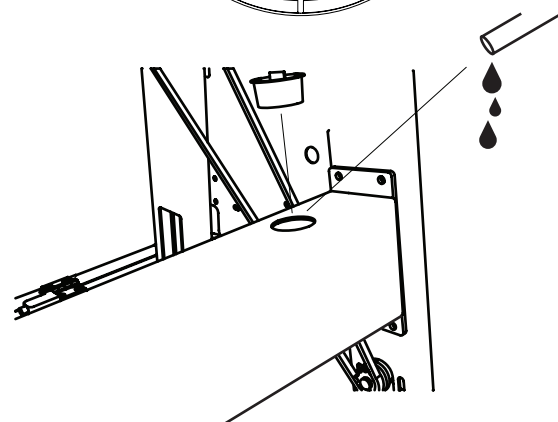

SET THE CRANK

The crank has to be adjusted for the gauge on the crankshaft to work. This is done by lowering the saw head to the bottom position and then releasing the crank adjustment plate. Now raise the saw head until a number on the crankshaft appears in front of the pointer in the handle tube. Which number is of no importance, as long as it is in the middle of the pointer. Then tighten the screw joint. Complete the assembly by tightening the chain adjusting screws until the saw head rests once more on the stops in the main post. Take care to ensure that both sides are adjusted to exactly the same extent in order to keep the blade parallel to the rail.

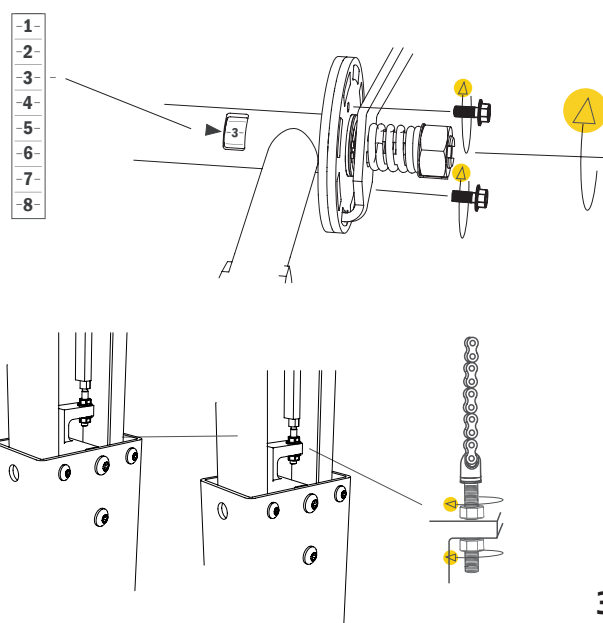

OTHER SETTINGS

SET THE CRANK SPRING

Tighten the lock nut in order to tension the spring so that the handle snaps back easily and locks in the crank pulley. When the handle is working properly, bend the lock washer to secure the lock nut in position.

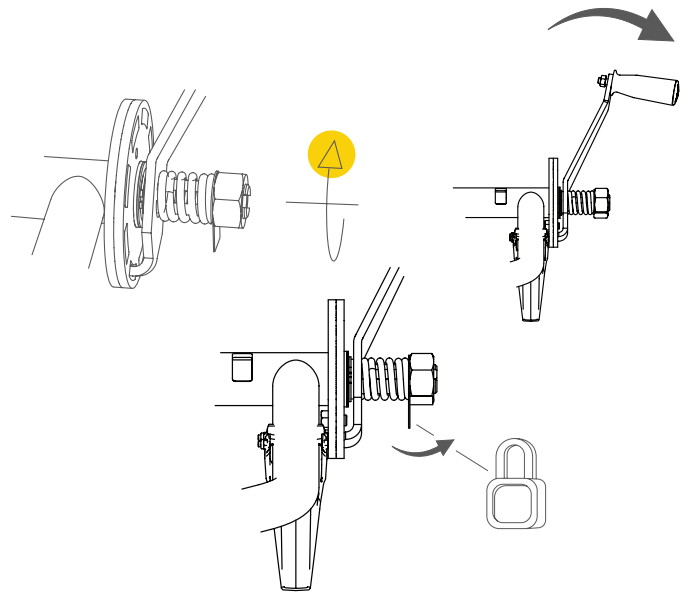

ENGINE INSPECTION BEFORE STARTING

The engine must be filled with oil and refueled before starting the sawmill for the first time. Place the saw head in the bottom position to make this job easier. Detailed information about the engine can be found in the engine's user manual, which is supplied.

Tip:

Work with the saw head in the bottom position to facilitate access to the engine.

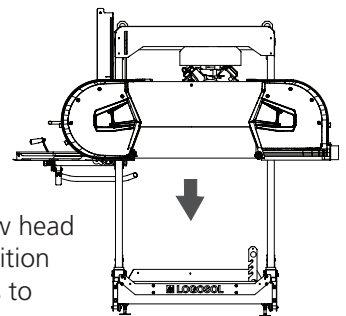

BLADE GUIDES

The blade guides clamp the blade down by 3 mm compared to the wheels.

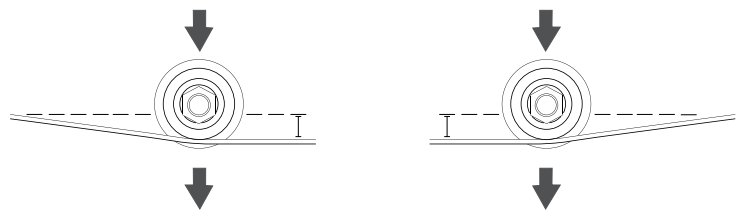

The guides can adjust the blade angle in the sawing direction by adjusting the upper and lower adjusting screws. The guides must be adjusted so that they are parallel to the trailing edge of the blade. This is done by adjusting the outer and inner adjusting screws. It is important for the blade guide roller to run parallel to the blade. Be thorough when setting this feature.

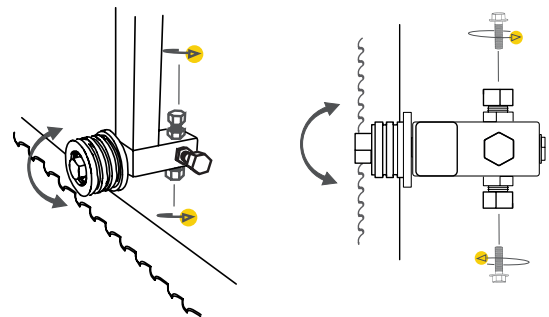

The guides can be adjusted in and out by pulling the shaft after releasing the adjusting screws. The trailing edge of the blade should be about 3 to 5 mm from the flange of the blade guide roller.

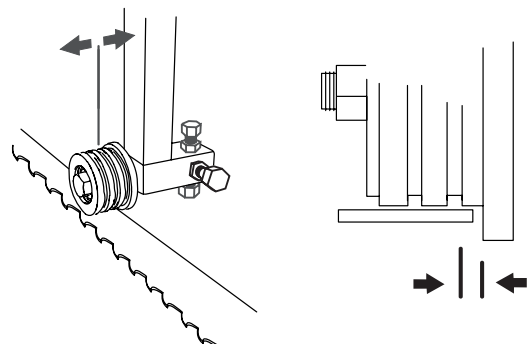

SAWMILL FEATURES

CRANK FEATURE

The crank used to move the saw head up and down is spring-loaded and must be pushed against the machine to release the locking mechanism while raising or lowering the saw head.

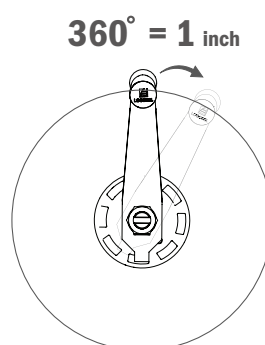
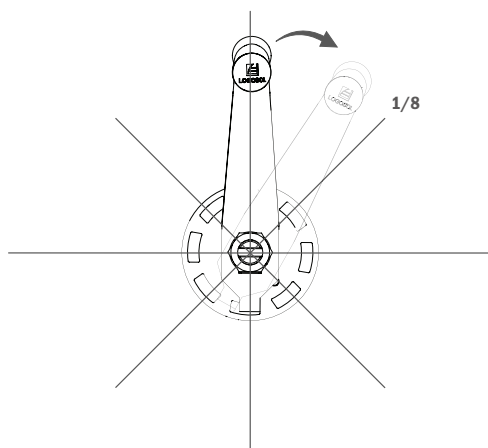
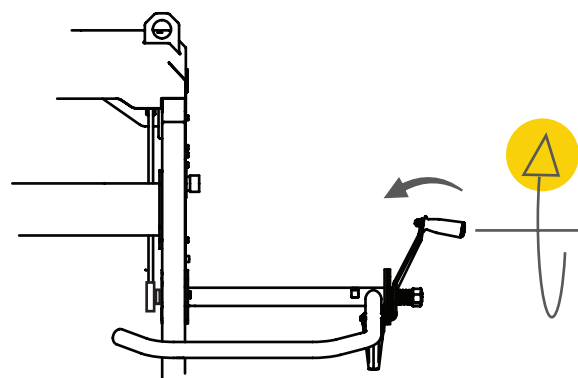

The crank locking mechanism is divided into eight positions on a single rotation. Each position is equivalent to movement of the saw head by an eighth of an inch, and a full revolution is equivalent to 1 inch. A 16-step dividing plate is available as an accessory.

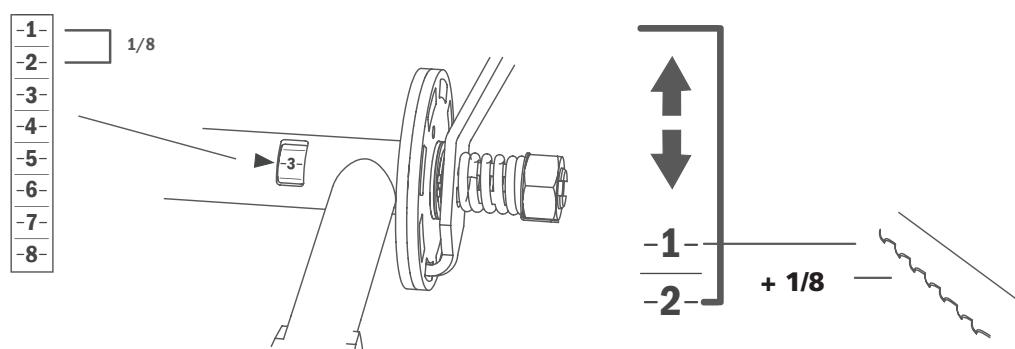

There is an opening on the shaft of the crank where a number can be seen. This is numbered in eight steps, each step being equivalent to one-eighth of an inch. **TIP:** You must always compensate for the thickness of the saw blade, i.e. 1/8", when sawing a board on the top side of the saw blade. There is never any need to compensate for the piece of wood on the underside of the blade. This has the dimension found on the absolute height gauge.

How to use the crank gauge to help with setting the saw

Example 1: If you are sawing a 1" board and the crank gauge shows "3", lower the saw head one turn first to get back to "3", then lower it another step (1/8") to the number "4".

Example 2: To saw a 2" board when the crank gauge is at "3", lower the saw head by two turns and stop at "2".

Example 3: To saw a 3/4" board when the crank gauge is at "3", lower the saw head by six-eighths plus one step for blade compensation, then stop at "2".

SAWMILL FEATURES

GAUGE FEATURE

The sawmill has two gauges: a millimetre gauge showing the distance between the log bed and the saw blade, and a blade-compensated gauge showing a range of different board thicknesses in inches. The blade-compensated inch gauge can be adjusted using a knob which is located at the bottom of the gauge. One additional feature is the Last Cut indicator, which is used as an instrument to help the user to remember the saw head position at the last kerf.

LAST CUT INDICATOR

To use the Last Cut feature, push the knob down against the pointer before you start sawing. When the saw head is then raised in order to retract the machine prior to the next kerf, the knob "remembers" where the saw head was at the last kerf. When the saw head is then lowered for the next kerf, the Last Cut knob can be used as a reference for the last cut surface.

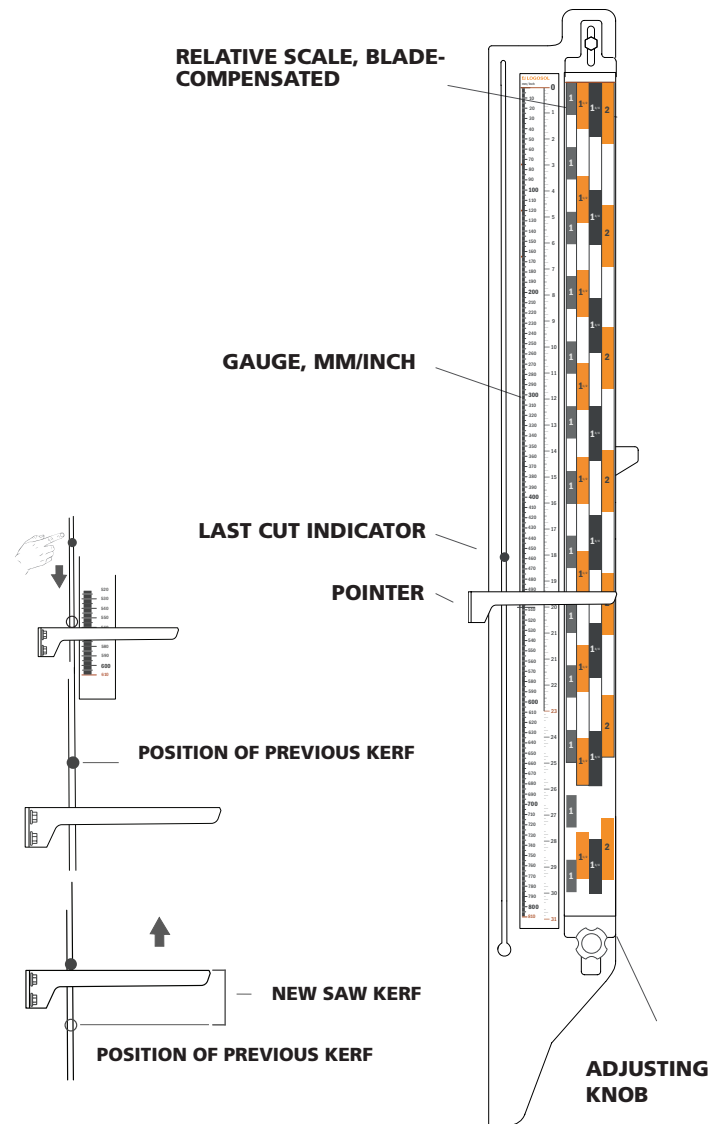

PARKING LOCK

The sawmill comes equipped with two hasps that lock the saw head in position when it is moved towards the end stop at either of the rail ends. To release the lock, lift the hasp with your foot before moving the saw head. On the rail end, the lock can be lifted so that it does not lock automatically by removing the screw that restricts the movement of the lock.

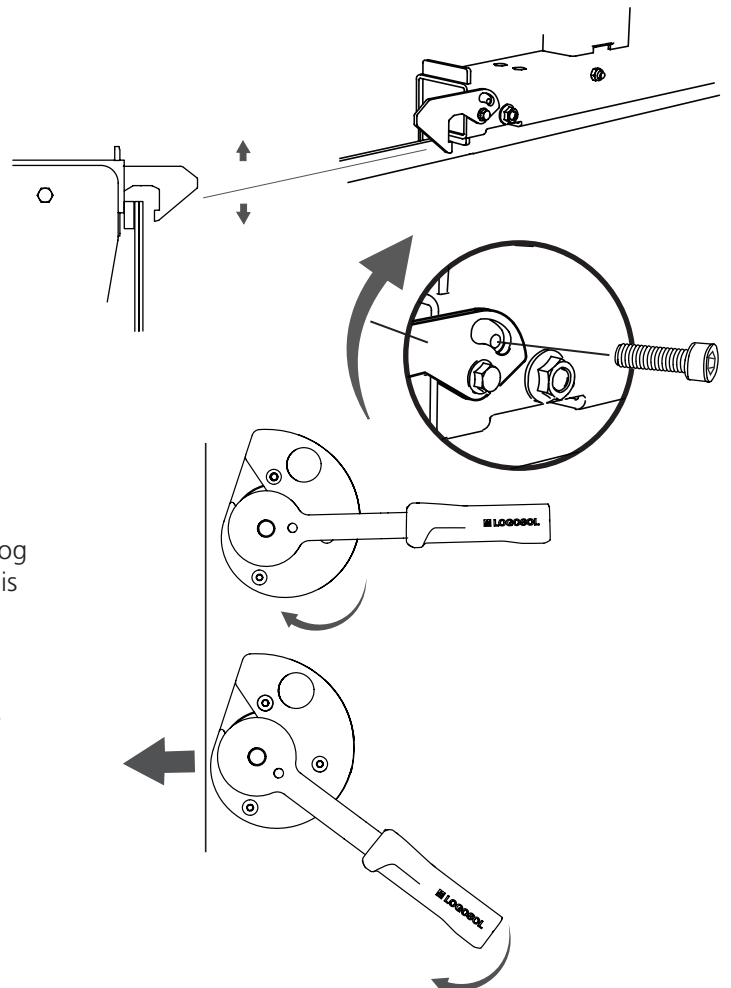

LOG CLAMP

The sawmill comes with two log clamps so that the log can be secured when sawing. The log clamp feature is eccentric.

Start by adjusting the eccentric plate so that it rests against the log that is to be clamped. This is done by rotating the plate clockwise. Continue tensioning by turning the handle clockwise as shown. The actions are performed in reverse order in order to release the tension. The plate and handle are then turned anticlockwise.

SAWMILL FEATURES

WATER COOLING

Water cooling is controlled by means of a lever in the side panel in front of the operator. The lever is perpendicular to the panel in its initial position. The lever is pulled backwards to turn on the water flow. The water cooling flow is adjusted by clamping the cooling hose in the elongated groove in the motor shelf.

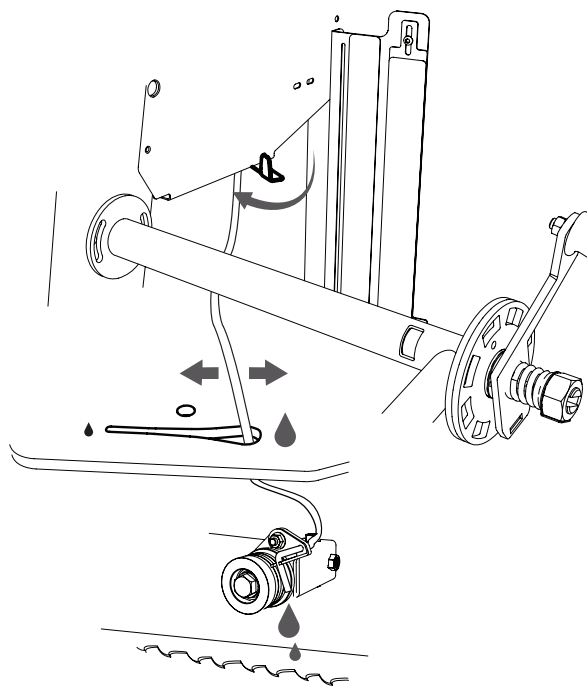

WIRING DIAGRAM

SAFETY SWITCH WIRING DIAGRAM

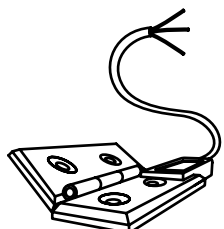

Elesa CFSQ,
60-SH-6-FAS-2

Safety switch

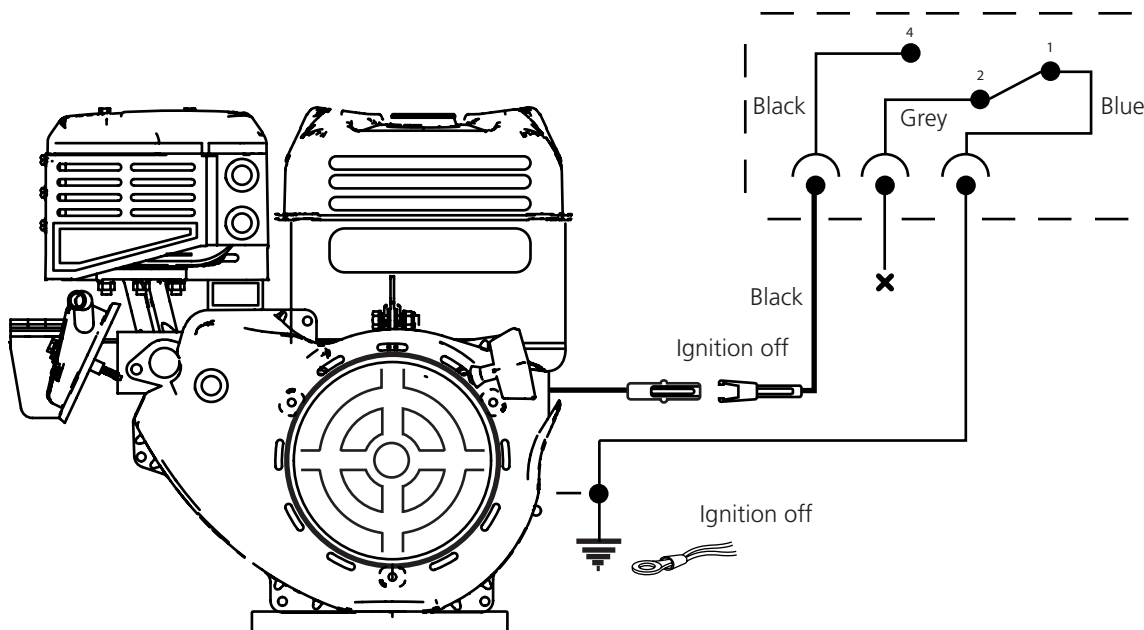



USE

USE

 **WARNING!** Cutting tools: Always stand behind the saw carriage and keep both hands on the handles when operating the machine. Never stand in front of the saw carriage or bandsaw blade. Never pull the saw carriage through a kerf.

 **WARNING!** Risk of entrapment and rotating parts: Even slight pressure on the saw head release mechanism can cause the saw head to drop in an uncontrolled manner and the crank to start rotating at speed, which may result in injury.

 **WARNING!** Never modify this machine so that it no longer conforms to the original configuration. Do not use the machine if it has been modified. Never use any accessories apart from those that are recommended in this user manual.

 **WARNING!** A broken bandsaw blade can eject bandsaw blade fragments at high speed via the chip ejector.

 Make sure there is no one on the chip ejection side of the band sawmill while it is working. The risk of bandsaw blade breakage increases if it has not been properly fitted or maintained.

 The bandsaw blades and plastic sawmill parts are resistant to temperatures down to -25 °C. Do not use the band sawmill in temperatures below -25 °C.

 Make sure that the machine has been properly assembled and maintained in line with the enclosed assembly instructions as well as these instructions.

 Never work alone. Always make sure there is another adult within earshot in case you need to call for help.

 Do not stand between the log pile and the band sawmill. Always stand to the side of the log pile when handling the logs. Never stand in any location where a log may fall on you.

 **WARNING!** Risk of flying fragments from dirty logs.

 Always inspect the logs so that there are no objects wedged in the bark before sawing.

 Load and turn logs carefully. The sawmill has a recommended maximum log weight of 1500 kg, but even smaller logs can damage the sawmill if handled incorrectly.

Hazard area:

 The minimum safe distance around the band sawmill is shown in Figure 1: see next page. Note that the safe distance on the left side of the band sawmill is 15 metres, as there is a risk of saw blade parts being ejected through the chip ejector if the the saw blade breaks. The extent of the hazard area on the other sides is 5 m. [Figure 1]

 **WARNING!** Keep hands, arms, legs and other body parts well away from the bandsaw blade, cables and other moving parts.

 **WARNING!** Risk of impact from the saw carriage.

 Always use the parking lock when working with the saw carriage.

 **WARNING!** Risk of tripping on rail and crossbars.

 Never take a short cut over the rail. Suspend electrical cables so that they are not damaged and do not present a trip hazard.

 **WARNING!** Never run the combustion engine in enclosed spaces. Ensure good ventilation. The exhaust gases contain harmful substances that are potentially fatal.

 **WARNING!** Risk of entrapment between the sawmill and the log during loading.

 The log pile must always be secured by placing a reliable retaining strap around the logs, for example (see Operating instructions).

 Never climb onto the rail or the log bed crossbars.

USE

Hard knots may cause deviations in the outcome of the sawing.

BEFORE EACH USE:

Check that

- the operator is wearing the prescribed personal protective equipment
- the maintenance prescribed has been carried out
- the bandsaw blade is stationary while the engine is idling
- the machine has been erected so that it is stable and the rail is supported along its entire length
- the saw carriage's anti-tip wheels and the rail's end stops are in place
- all components on the band sawmill are secure and serviceable
- all the safety equipment on the machine is in place and in proper working order
- the bandsaw blade is properly installed and runs freely in the right direction.

Before each kerf:

Check that

- there are no other persons or pets within the danger zone of the machine
- there are no obstacles at the work site that could cause a trip hazard or be a nuisance

- the bandsaw blade runs clear of the log supports and log clamp
- the rail is clear of debris, dirt, etc.
- the workpiece is secured in place
- the adjustable saw blade guard is set correctly to accommodate the maximum width of the workpiece.

When in use:

 **WARNING!** Risk of burn injuries. The engine and its silencer become very hot during operation, and remain hot for a while after the engine has been shut down. This also applies when the engine is idling.

 **WARNING!** Fire hazard. Petrol and petrol vapours are highly flammable. Bear in mind the fire, explosion and inhalation hazards involved.

 The engine must have been shut down and allowed to cool for 10 min before fuel is added.

Always shut down the combustion engine when leaving the operator station, even you are only away for a few moments to deal with sawn timber or carry out maintenance.

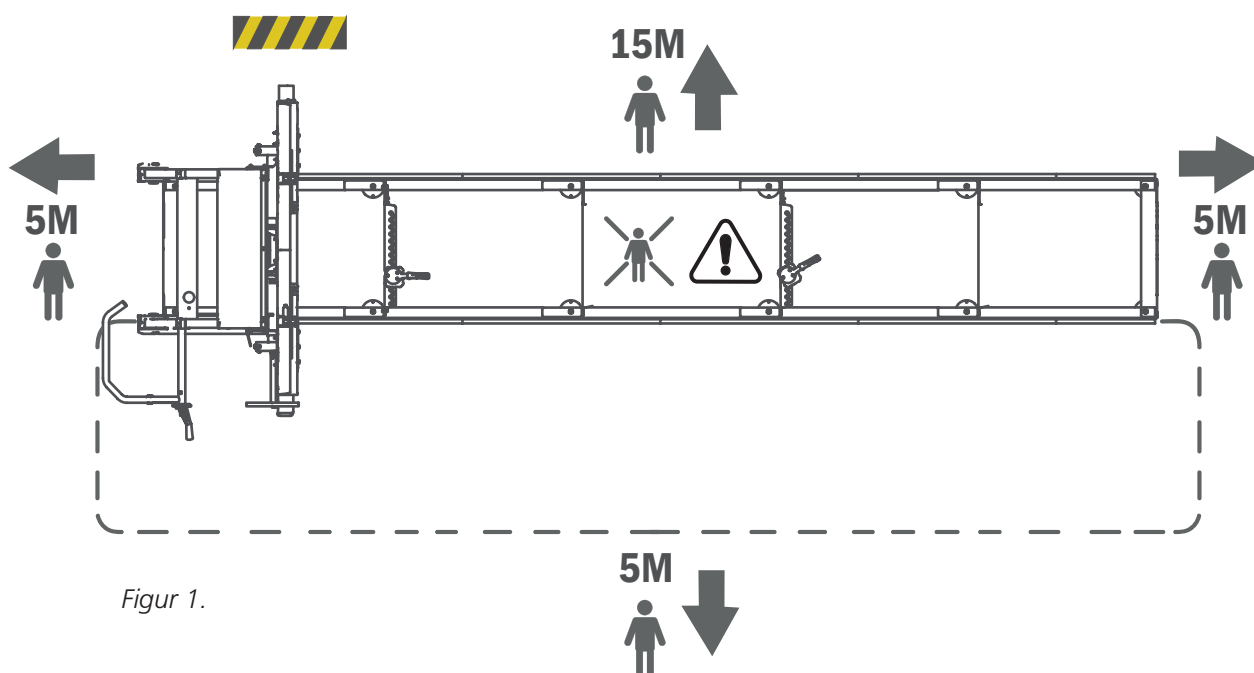

Figur 1.

USE

STORAGE

The bandsaw blade must be removed from the machine and stored out of reach of children and other persons, even if the machine will not be used for just a short time.

When stored for longer periods the following applies:

- the fuel tank and coolant reservoir are emptied,
- the bandsaw blade is removed from the machine,
- the fuel tap is closed,
- the saw carriage is locked in position.

Store the band sawmill in a place that is not accessible to children or other persons, preferably in a locked room.

- ! Blade tension must be released at the end of each completed shift to reduce wear on the bandsaw blades.

MAINTENANCE

- ! **WARNING!** Risk of serious injury.

- ! Turn the ignition switch to OFF and close the fuel valve before servicing or performing maintenance on the machine.

- ! **WARNING!** Risk of burn injuries. The engine and its silencer become very hot during operation, and remain hot after the engine has been stopped.

- ! Allow the engine and silencer to cool down before servicing or performing maintenance on the machine.

CHIP COLLECTION

The sawmill can be run without chip extraction if it is used outdoors.

- ! Make sure that the sawdust collecting at the machine is removed at regular intervals using a spade, for example. A capacity of at least 800m³/h is required if chip extraction is connected.

MOVING THE BAND SAWMILL

- ! **WARNING!** Risk of entrapment.

- ! When lifting and moving machine parts, keep persons and animals outside the 5 m danger zone around the machine. Secure the load during transport.

- ! The saw carriage and rail component must not be lifted or transported while assembled, but must be transported separately.

Lifting the saw carriage: Remove the anti-tip wheels of the saw carriage, one on either side, and then use safe lifting equipment to lift the saw carriage using the lifting eyes right at the top of it. Weight, see Technical data.

Lifting of rail component: Use pallet forks or a fork lift to lift the rail from below. Place a protective layer of wood material on the forks before lifting. Make sure that the rail component is well balanced and secure the load to the pallet fork before transporting it. Weight, see Technical data.

REFUELLING

- ! **WARNING!** Risk of burn injuries. Petrol is a highly flammable liquid.

- ! Wait until the machine's engine has cooled down before refuelling it. Turn the ignition switch to OFF and close the fuel valve.

Refuelling: refuel the engine with the saw head in its bottom position and the saw carriage in its locked position at either end of the rail. Use a funnel and try your best to avoid spilling fuel.

- ! Extraction hose: Any extraction hose connected to the sawmill must be fitted with a coil that can be earthed.

STARTING AND STOPPING

STARTING

1. Open the fuel valve by moving the slide control to the right to the "ON" position.
2. To start a cold engine, set the choke to closed position (lever to the left). To start a warm engine, leave the choke in open position (lever to the right).
3. Set the ignition key to "ON".
4. Gently pull the starter handle until you feel resistance, then pull firmly. Carefully return the starter handle.
5. Open the throttle by squeezing the throttle control all the way to the end position. This will increase the speed of the combustion engine to its operating range, and the bandsaw blade will start.
6. If the choke is in closed position, gradually move the control to open position as the engine warms up.

STOPPING

The saw blade is stopped by releasing the throttle control on the push handle. The bandsaw blade is then decelerated to a standstill, and the engine drops to idling speed. Then shut down the engine by turning the ignition key to "OFF" and then closing the fuel valve.

OPERATING INSTRUCTIONS

LOG PILE

Do not make the log pile more than 1 m high.

Logs that are contaminated with earth, sand or clay significantly reduce the service life of the bandsaw blade and increase the risk of it breaking. Avoid dragging the logs along the ground, and try to keep them as clean as possible

It may also be a good idea to separate out the various types of timber into different log piles.

LOG TABLE

Logs can be loaded from either side of the band sawmill. The log pile must be secured before each sawing operation if it is on the same side as the operator.

Set the log table to the same height as the crossbars on the bandsaw. The log table should end 10 cm from the band sawmill if it is placed on the left side of the band sawmill. If the log table is placed on the operator's side, it should stop about 1 m from the band sawmill and movable ramp boards should be used between the log table and the sawmill. Make sure the log table has large wedges at its trailing edge so that the logs cannot roll off.

 Make sure that the logs nearest to the band sawmill are secured to prevent them rolling towards the band sawmill while it is running. [See Figure 2]

LOADING LOGS

 **WARNING!** Risk of entrapment between the log and the band sawmill.

 Always stand to one side of the log table when handling the logs. [See Figure 3, area A]

 Try not to stand between the log table/log pile and the band sawmill. The log pile must always be secured when you are in area B [see Figure 3].

 The logs must be rolled off the log table. Do not drop them onto the band sawmill.

When loading a log:

1. Place the saw carriage as far back on the rail as possible (its starting position).

2. The log supports must be raised to their top position when loading logs from the operator's side. The log supports must be moved over to the opposite side of the rail (the operator's side) and mounted in their top position when loading logs from the left side of the band sawmill. The log supports are moved back to the left side of the band sawmill when the log is stable on the rail.

3. If the log table comes with a detachable ramp, fit it so that there is no gap between the log table and the band sawmill.

4. Disconnect the locking device for the front logs on the log table.

5. Roll out a log.

6. Secure the logs at the very front of the log pile.

7. Carefully roll the log onto the log supports of the band sawmill. Use a log turner. Centre the log laterally over the crossbars of the log bed.

8. Adjust the log supports so that they support the log but do not come into contact with the saw blade. Lock the log supports in position.

9. Adjust the log clamps so that they are in the middle of the log supports on opposite sides of the log. Adjust the height of the log clamps to lock the log in place. However, ensure that the log clamps cannot come into contact with the bandsaw blade.

OPERATING INSTRUCTIONS

OP:1

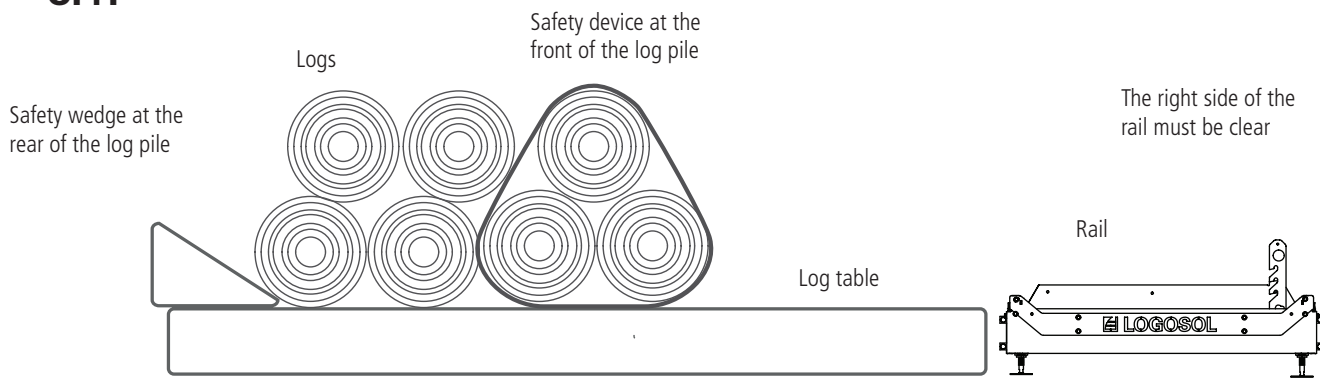

OP:2

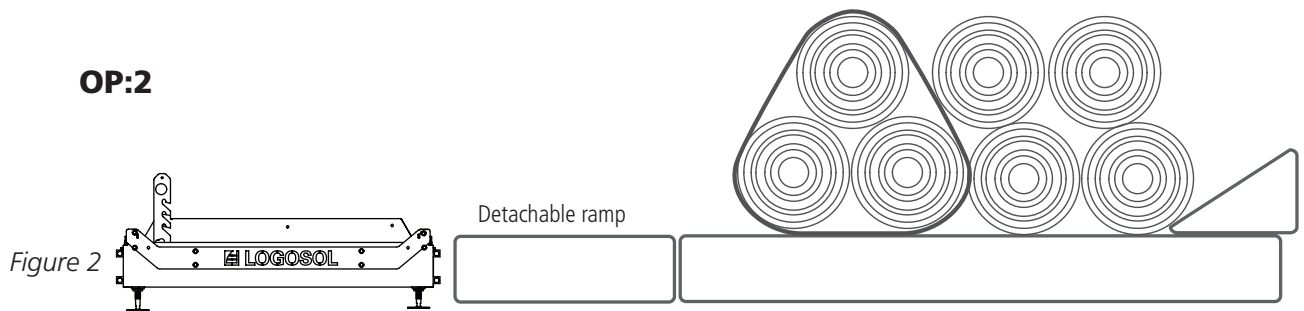
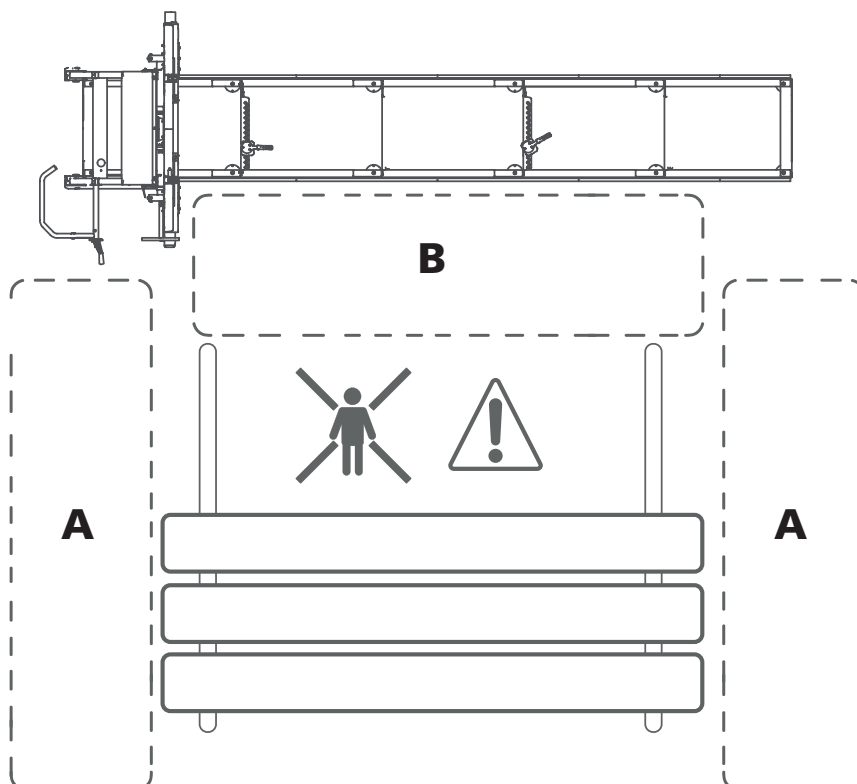

Figure 3



OPERATING INSTRUCTIONS

ADJUSTING THE SAW KERF

The position of the saw head can be adjusted in increments to set the depth of the cut. The B751 PRO band sawmill comes equipped with 1", 1 1/2", 1 3/4" and 2" gauges with saw kerf compensation as standard. The cutting depth is set using the crank on the saw head. Crank down until the mark on the selected gauge is level with the pointer.

SAWING

WARNING! Cutting tools:



Always stand behind the saw carriage and keep both hands on the handle when operating the machine. Never stand in front of the saw carriage or saw blade. Never pull the saw carriage back through a kerf.



WARNING! Read through and follow all safety instructions described under *Before each saw kerf* in the *Safety instructions* section.

1. Perform all the checks described under *Before each use* in the *Safety Instructions* section before using the sawmill.

2. Raise the log supports by unhooking them and placing them at the preferred height.



WARNING! Risk of entrapment.



Watch your fingers when the log supports are lowered. Check that the log supports are pushed down properly into the fixed positions.

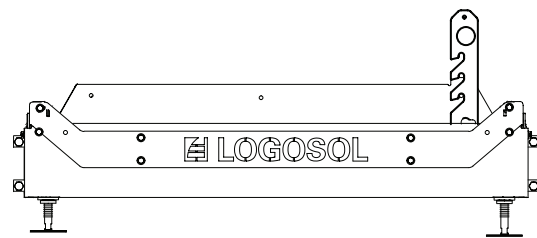

3. Use the log turner accessory when rolling a log onto the log bed. Centre the log on the log bed and roll it towards the log supports. Check the position of the log on the log bed. To ensure the log is cut fully in half, the end must not lie beyond the last crossbar.

4. Rotate the log into a position that gives the best sawing yield.

5. If the log clearly tapers from one end to the other, it is necessary to compensate for this in order to achieve the best possible results. You should always try to saw parallel to the centre line of the log. Place a spacer between the crossbar of the log bed and the narrow end of the log.

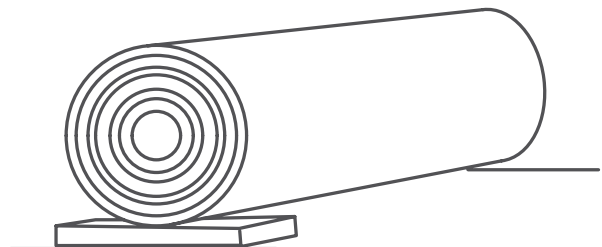

Using a spacer.

OPERATING INSTRUCTIONS

6. Secure the log using the log clamps. Adjust the height of the log clamps, but do not position them so high that the saw blade may come into contact with them.

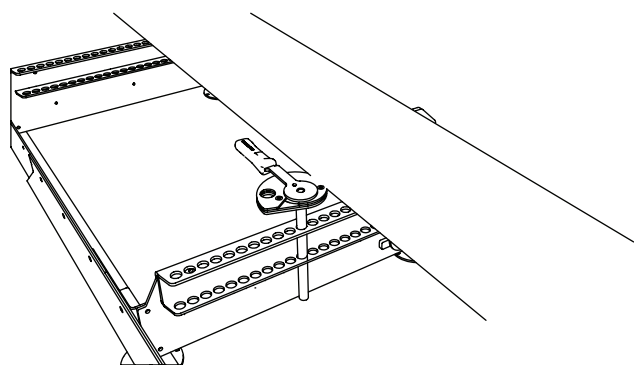

Log clamps. Use of two log clamps is recommended.

7. Set the height of the saw head for the first kerf using the kerf depth crank. Turning the crank clockwise raises the saw head, and turning it anticlockwise lowers it.

8. Check that the saw blade runs clear of the log supports and log clamps.

9. Set the adjustable saw blade guard to allow for the widest part of the log.

10. Open the saw blade flushing valve so that water drips onto the blade guide roller/saw blade.

11. Before each saw kerf, perform all checks referred to under *Before each saw kerf* in the *Safety instructions* section.

12. Stand behind the push handle of the saw carriage, then start the combustion engine. Open the throttle by squeezing the dead man's switch all the way in. This will increase the speed of the combustion engine to its operating range, and the band wheels/saw blade will start to move.

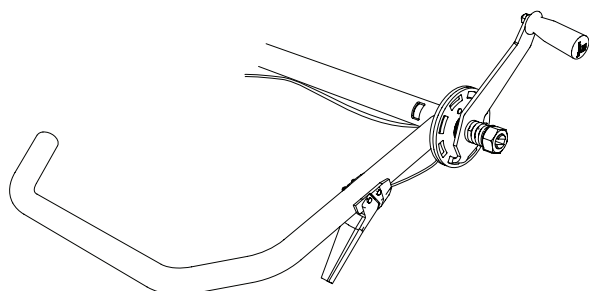

Push handle with dead man's switch.

13. Placing both hands on the push handle, carefully push the saw carriage forward until the saw blade starts to cut into the log. The feed rate can be increased once the entire bandsaw blade is engaged in the log. Keep adjusting the feed rate to ensure the kerf is straight and smooth. Reduce the feed rate when cutting through knots in the log, and select a lower feed rate when sawing coarser logs and harder timber varieties. Also reduce the feed rate as you approach the end of the log.

14. As soon as you have sawn through the log, release the dead man's switch and stand still until the saw blade has come to a complete stop. Tip: The blade will stop more quickly if you release the throttle just before the blade cuts through the log.

15. Remove the sawn section from the log.

16. Raise the saw head slightly and return the saw carriage back to its starting position by hand.

17. Set the height of the next kerf. Use the crank and read off the gauges.

18. Turn the log through 180° so that the freshly sawn surface is lying against the log bed.

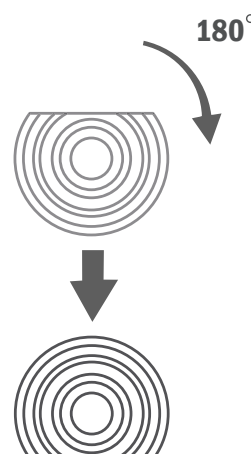

Turn the log through 180° so that the freshly sawn side faces towards the log bed.

Lower the log supports and log clamps so that they cannot come into contact with the saw blade, then clamp the log in position. Saw until you achieve the preferred block width.

OPERATING INSTRUCTIONS & MAINTENANCE

Turn the log through 90° so that one of the freshly sawn sides rests against the log supports, then clamp the log in position. Now you can make the third kerf and obtain finished boards. It may be necessary to compensate for the taper of the log in this situation. Lower the saw supports as you go and saw up the block with the bark facing down.

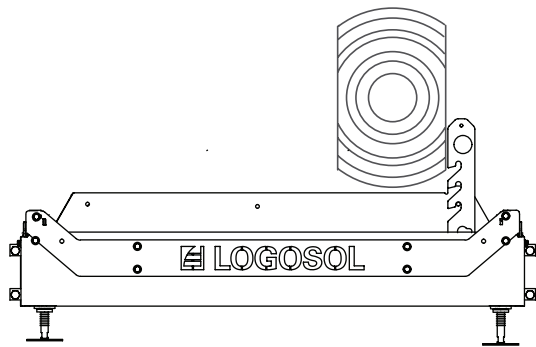

Turn the log through 90° so that one of the freshly sawn sides rests against the log supports, then clamp the log in position.

19. When the log has been turned for the last time in order to saw the last few boards, it is necessary to work out where to start so that everything lines up at the end. It is possible to check this by lowering the saw blade so that it rests against the log. It is then possible to use the absolute gauge to read off how much timber is left under the saw blade. Set the saw head to the preferred height.

TIP: The easiest way to go about it is to hold off on turning the block until there is only enough material left for a 2". Counting is then unnecessary.

HANDLING OF SAWN TIMBER

When sawing boards from the block, you can either lift them off the block straight away or leave them where they are and saw a number of planks before handling the timber.

When then lifting the planks off the rail, take care to ensure that the saw head is locked to one of the ends of the rail. Then move the sawn timber to a stacking area. Place straw between the layers of planks to facilitate drying.

MAINTENANCE

The periodic maintenance on the machine that is expected to be performed by the operator is described in this section. Be sure to follow the specified maintenance intervals, as this is the basis for good function of the sawmill.

WARNING! Risk of serious injury:

Turn the ignition switch to OFF and close the fuel valve before servicing or performing maintenance on the machine.

WARNING! Cuts:

Coiled bandsaw blades may unexpectedly burst open with considerable force. Handle coiled bandsaw blades with great care.

WARNING! Fire risk:

Do not smoke or carry out any work (welding, grinding, etc.) on the band sawmill that could cause sparks that may potentially cause ignition in the vicinity of fuel or combustible materials.

Immediately clear up any fuel spilt on the machine while refuelling it. Change your clothes immediately if you get fuel on them.

Never run the engine if there is a fuel or oil leak. Always turn the engine off before refuelling.

MAINTENANCE

HANDLING SAW BLADES

 **WARNING!** Cutting tools: Incorrect handling of bandsaw blades may result in potentially fatal injuries. Saw blades are extremely sharp.

 **WARNING!** Risk of sustaining cuts.

When handling saw blades:

- always wear protective leather gloves (class 1)
- always wear close-fitting protective eyewear or a visor
- wear protective footwear with saw protection, steel toe-caps and non-slip soles
- always wear full-length protective trousers
- keep persons and animals at a safe distance, at least 5 m

REPLACING BANDSAW BLADES

It is important to replace the saw blades regularly for maximum cutting performance. Fifteen to thirty logs can normally be sawn before replacing the blade, but this is very much dependent on how contaminated the bark is. Using blunt saw blades will result in crooked or incomplete kerfs, reduced saw blade service life and greater risk of saw blade breakage. Always wear protective leather gloves when handling saw blades.

To remove the saw blade:

1. Release the blade tension by turning the T-handle counter-clockwise.
2. Open the covers over the band wheels.
3. Remove the saw blade from the band wheels.

Fitting a new saw blade:

1. Position the saw blade under the blade guides first and then round the band wheels. Make sure that the saw teeth point towards you
2. Rotate the bandsaw blade by hand in the kerf direction and check that the tracking of the bandsaw blade has not changed. See Setting the longitudinal blade position on page 34.
3. Replace the band wheel guards.
4. Close the hatch.

LUBRICATION POINTS

It is important to lubricate the components of the sawmill as described below in order to ensure your sawmill remains in good condition for many years,

and to ensure problem-free ownership. Lubrication must be carried out:

- Immediately after assembly and before starting to use the sawmill.
- Every 50 hours of operation, but at least once a year.

The lubricants to be used on the sawmill are:

- Superflo SKU: 9999-000-5115
- Universal lubricating oil SKU: 9999-000-5105
- Silicone SKU: 9999-000-5110
- Grease ISO-L-XCCIB2

Rail pipe sections

Lubricant: Universal lubricating oil

Insert the nozzle of the spray can into all openings and spray the inside of the pipe sections to protect against corrosion.

Top sections of the rail on which the saw carriage travels

Lubricant: Universal lubricating oil

Blade tensioning T-handle

Lubricant: grease or Superflo

Unscrew the T-bar and apply copious amounts of lubricant to the threaded rod.

Saw head lifting chains and chain transmission

Lubricant: Superflo

Lubricate the whole chain.

Lifting winch shaft

Lubricant: Superflo

Grease both sides from the outside.

The petrol engine's throttle cable and handle

Lubricant: Superflo

Lubricate the joints of the handle and spray oil into the cable from the ends. If the cable is hard to move, remove the cable from its housing, lubricate it along its entire length and spray oil into the cable housing.

Saw carriage main post

Lubricant: Silicone

Lubricate the sliding surfaces of the saw head and the plastic guides.

MAINTENANCE

CLEANING THE BAND SAWMILL

Clean the band sawmill after every shift. Brush out any wood chips or sawdust inside the band wheel guard and on and around the rail. Wipe down painted surfaces and plastic parts with silicone spray (SKU: 9999-000-5110). Lubricate moving parts with Superflo (SKU: 9999-000-5115).

WATER RESERVOIR

Empty water out of the container and pipes if the temperature drops below zero. Washer fluid may be used as a lubricant at sub-zero temperatures. Never use glycol or flammable liquids as a coolant.

HORIZONTAL SAW BLADE ALIGNMENT

Check that the saw blade is parallel to the log bed before every shift.

COMBUSTION MOTOR

Check the oil level in the motor before every shift. Follow the maintenance schedule in the instruction manual for the engine.

SAW HEAD LIFTING CHAINS

Check the saw head lifting chains for damage. Replace the chains if necessary.

VERIFICATION OF SAFETY FEATURES

Check the operation of the following safety features before every shift: Check that the throttle handle returns so that the engine idles when the handle is released. If it does not, lubricate the throttle cable with Superflo (SKU: 9999-000-5115). Check that the switch in the saw guard hinge is working. Checks are performed by opening the covers with the motor off and listening for the switch to trip.

RAIL FLATNESS

Check the balance of the rail before every shift, particularly in winter when frost may affect the surface.

BAND WHEEL BELTS

Regularly check the condition of the drive wheel belt and the belt for the undriven wheel. Replace any worn or damaged parts. Regularly check the tension of the drive belt and adjust as required.

BLADE GUIDES

Regularly check the condition of the blade guide rollers and make sure the distance between the flange of the blade guide roller and the bandsaw blade is within 3-5 mm. Replace any worn or damaged blade guides.

BAND WHEEL GUARDS

Clean the inside of the belt wheel guards and the saw blade to remove sawdust and shavings after every hour of work or when replacing the saw blade.

BANDSAW BLADE

Replace the bandsaw blade with a new, sharp one about every two hours of effective sawing.

TROUBLESHOOTING SCHEDULE

PROBLEM/SYMP TOM	PROBABLE CAUSE	ACTION
The saw blade quickly loses its edge	<ul style="list-style-type: none"> • Dirty logs • The saw blade is worn out 	<ul style="list-style-type: none"> • Avoid dragging the logs over the ground. • Debark the log at the point where the saw blade is to cut • Saw square blocks off the logs before sawing boards to reduce the number of cuts made through bark. • Replace the saw blade
Crooked kerf	<ul style="list-style-type: none"> • Blunt saw blade • Feed rate too fast • Feed rate too slow • Sawing into partially frozen log 	<ul style="list-style-type: none"> • Regrind the saw blade • Reduce the feed rate • Increase the feed rate • Leave the log to thaw or become completely frozen before sawing. TIP: Do not approach the log tentatively; allow the blade to make contact with the end of the log directly at an adapted cutting speed.
The saw blade works downwards or upwards while you saw	<ul style="list-style-type: none"> • Inadequate saw blade tensioning • Feed rate too fast • Saw blade damaged • Saw blade not tracking properly over the band wheels 	<ul style="list-style-type: none"> • Increase the saw blade tension • Reduce the feed rate • Replace the saw blade • Fit the saw blade correctly and adjust the tracking
Bandsaw blade breakage	<ul style="list-style-type: none"> • The saw blade is worn out • Saw blade blunt and/or fitted incorrectly • Saw blade over-tensioned • The blade guide rollers have not been fitted to match the band wheels • Worn shoes on the band wheels resulting in the bandsaw blade coming into direct contact with the metal 	<ul style="list-style-type: none"> • Replace the saw blade • Regrind the saw blade • Reduce the saw blade tension • Adjust the blade guides • Replace shoes on the band wheels
Uneven thickness of sawn wood	<ul style="list-style-type: none"> • The saw bed is springy due to insufficient support 	<ul style="list-style-type: none"> • Support the rail and log bed as instructed
The saw blade does not track and backs out of the band wheels	<ul style="list-style-type: none"> • Incorrect band wheel adjustment • Worn band wheel linings 	<ul style="list-style-type: none"> • Adjust the band wheels as instructed • Replace the linings
The saw blade does not cut	<ul style="list-style-type: none"> • Saw blade installed in the wrong direction 	<ul style="list-style-type: none"> • Remove the saw blade, turn it inside out and then refit it • When using the electric motor, check that the motor is running in the right direction, action: Reverse the electric motor.
The saw blade is under tension even though the blade tension has been released using the T-handle	<ul style="list-style-type: none"> • The blade tensioning mechanism is seized 	<ul style="list-style-type: none"> • Push the T-handle inwards
The saw head is hard to move up and down	<ul style="list-style-type: none"> • The vertical guides are too narrow • The drum of the saw head's lifting winch needs lubricating 	<ul style="list-style-type: none"> • Lubricate with silicone, and loosen the guides slightly where appropriate • Lubricate with Superflo
The saw head rattles when it is lowered	<ul style="list-style-type: none"> • The rail component is not flat and breaks in the saw carriage 	<ul style="list-style-type: none"> • Weigh down the rail component as instructed so that it is flat
The saw blade overheats when sawing	<ul style="list-style-type: none"> • There is no more water in the water tank • The water valve is closed 	<ul style="list-style-type: none"> • Top up water • Open the water valve
The motor/engine will not start	<ul style="list-style-type: none"> • The ignition switch is set to "OFF" • The cover switch is enabled 	<ul style="list-style-type: none"> • Turn the ignition switch to "ON" • Check function



Declaration of Conformity

In accordance with Directive 2006/42/EC, Annex 2A

Logosol AB
Arkivvägen 6
871 53 Härnösand

hereby declare that the **Logosol B751** mobile band sawmill

has been manufactured in conformity with:
Machinery Directive 2006/42/EC, EMC Directive 2014/30/EU

and has been manufactured in conformity with the following
harmonised standards:
EN ISO 12100:2010, EN 60204-1:2018,
EN 50370-1:2005, EN 50370-2:2003.

Notified body, 0404, RISE SMP Svensk Maskinprovning AB, Box
7035, SE-750 07 Uppsala, Sweden, has performed EC type
examination according to Directive 2006/42/EC, Article 12(3b).
The EC type examination certificate is numbered: 0404/17/2408

The band sawmill supplied is identical to the band sawmill that
underwent EC type examination.

Härnösand, 30 January 2026

A handwritten signature in black ink, appearing to read "R. Berglund".

Robert Berglund, CEO

LOGOSOL

Arkivvägen 6, SE-871 53 Härnösand
+46 (0)611-182 85 | info@logosol.com | www.logosol.com